

PACKAGING FEEDER SERIES

MODELS ►► SE 600 PC/PS SE 900 PC/PS SE 1200 PC/PS SE 1800 PC/PS

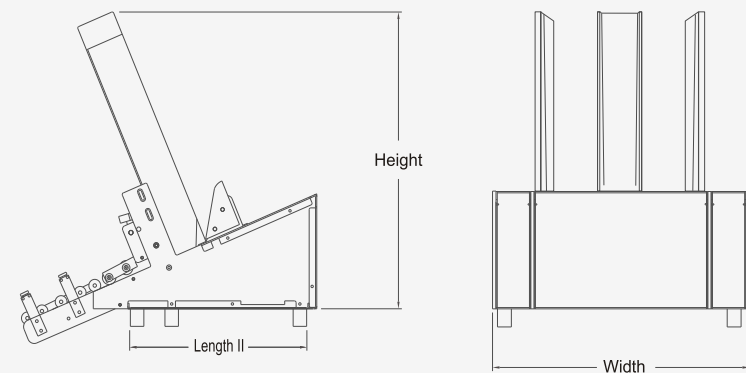

TECHNICAL SPECIFICATIONS	SE 600 PC/PS	SE 900 PC/PS	SE 1200 PC/PS	SE 1800 PC/PS
Product Size Maximum	6.75"W x 14"L	9 1/4"W x 14"L	12"W x 14"L	18"W x 14"L
Product Size Minimum	2.5"W x 2"L	2.5"W x 2"L	2.5"W x 2"L	2.5"W x 2"L
Product Thickness Max.	.75"	.75"	.75"	.75"
Product Thickness Min.	.002"	.002"	.002"	.002"
Sensor Trigger	Triangulated Beam	Triangulated Beam	Triangulated Beam	Triangulated Beam
Feeder Capacity	20" Vertical	20" Vertical	20" Vertical	20" Vertical
Time Delay	10MS – 5 Seconds	10MS – 5 Seconds	10MS – 5 Seconds	10MS – 5 Seconds
Electrical	120/240 VAC	120/240 VAC	120/240 VAC	120/240 VAC
Speed	20 to 525 ft./min	20 to 525 ft./min	20 to 525 ft./min	20 to 525 ft./min
Drive Motor	Variable DC	Variable DC	Variable DC	Variable DC
Warranty	2 Year Limited	2 Year Limited	2 Year Limited	2 Year Limited



FOOTPRINT	H	W	L
SE 600 PC	22.50"	7.5"	22.00"
SE 900 PC	22.50"	10"	22.00"
SE 1200 PC	22.50"	13.00"	22.00"
SE 1800 PC	22.50"	19.125"	22.00"
SE 600 PS	22.50"	7.5"	22.00"
SE 900 PS	22.50"	10"	22.00"
SE 1200 PS	22.50"	13.00"	22.00"
SE 1800 PS	22.50"	19.125"	22.00"

Applications: Wrapping, Boxing, Cartoner, Infeed Conveyor, Traying, Glue Tipping and fulfillment applications

Standard Features: Sleep Mode / Out of Paper / Paper Jam / Service Mode / Miss Feed / Total Counter / Batch Counting (PC Only) / Dynamic Rotation Technology / Single Shot on Demand, Time Delay

Optional Features: Double Detection / Auto Restart / PLC Interface / Mobile Stand

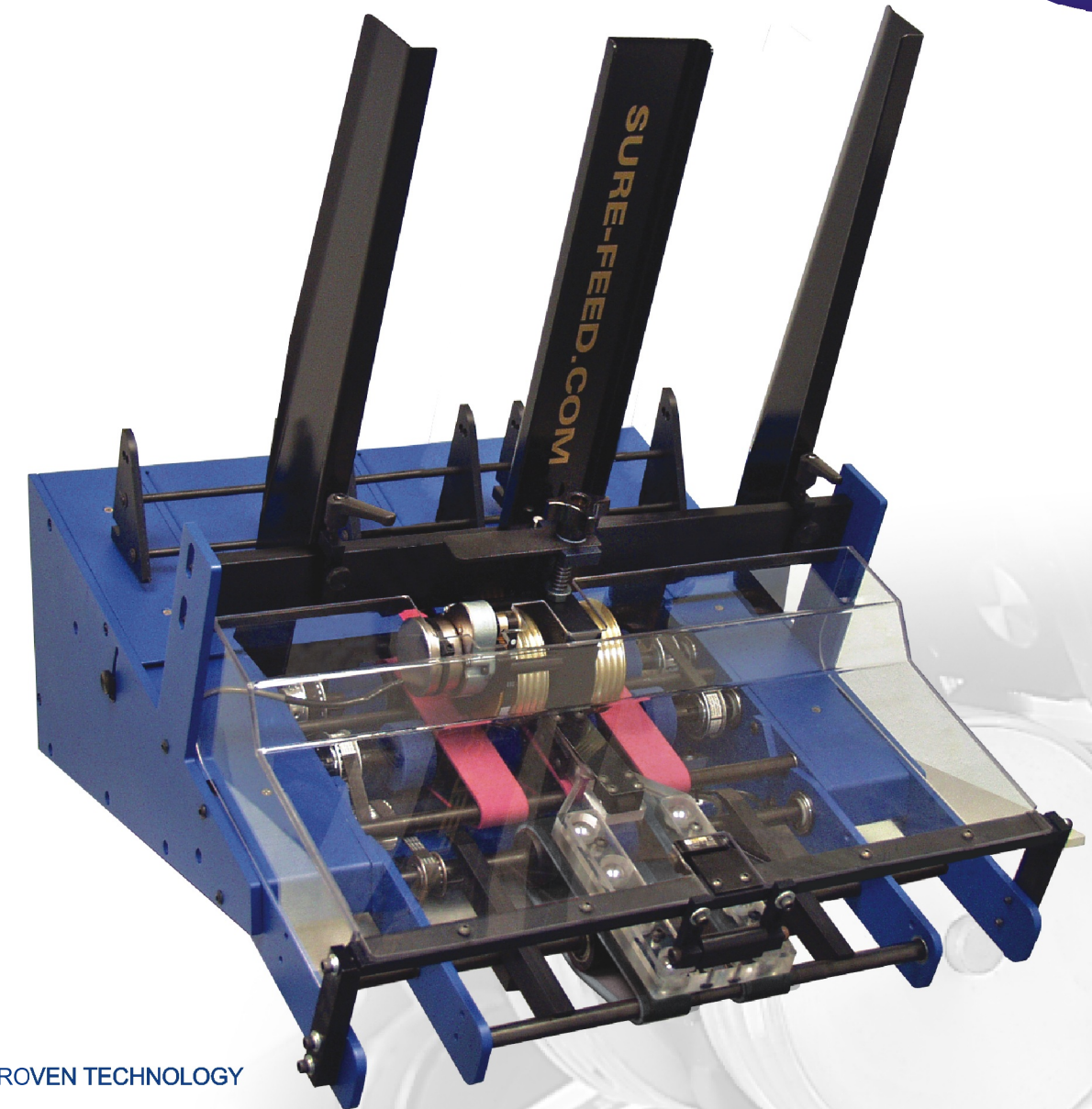

►► INDUSTRY PROVEN TECHNOLOGY

►► ACCURATE SEPARATION USING DYNAMIC ROTATION TECHNOLOGY

►► EASILY INTEGRATES INTO YOUR EXISTING PACKAGING LINE

►► MANY OPTIONS ARE AVAILABLE

TYPE OF UNIT: Packaging Feeder

600/900/1200/1800 - Wrapping, boxing, traying, glue tipping and fulfillment applications. Batch count feeding can be automated by the use of an on-demand feeder.



SURE-FEED ENGINEERING
12050 49th STREET NORTH, CLEARWATER FL. 33762-4301
PHONE: 727.571.3330 FAX: 727.571.3443 TOLL FREE: 1.800.INSERTER

PACKAGING

HIGH CAPACITY FEEDING SYSTEMS WITH DYNAMIC ROTATION

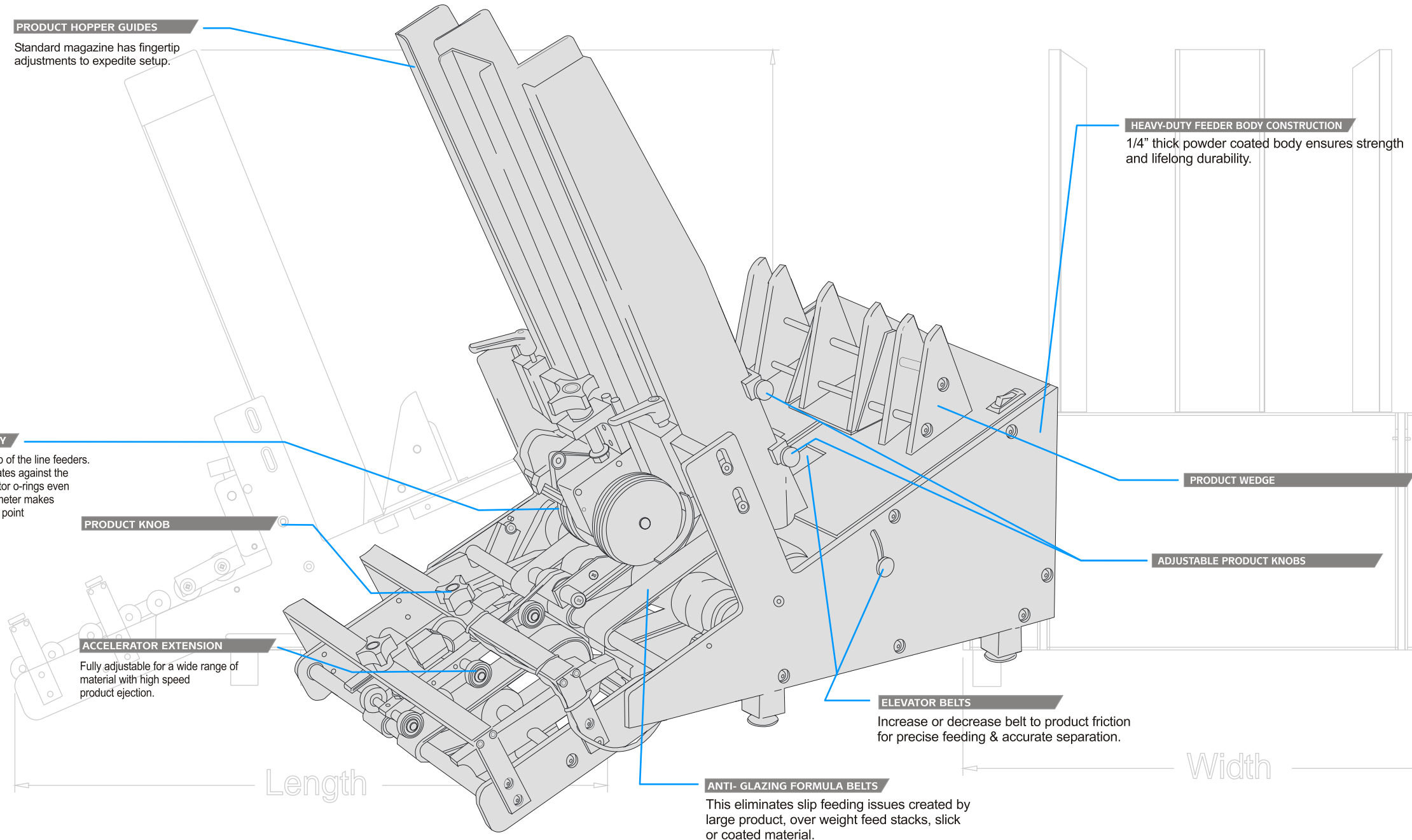

Technical Information



►► 18" Packaging feeder integrated to a flighted conveyor

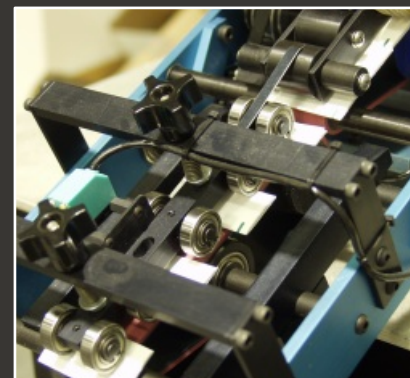

►► The accelerator extension creates a perfect separation for single shot or batch counting



►► The ejection carriage creates a perfect separation for single shot or batch counting

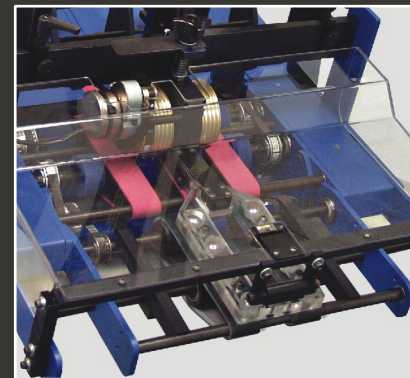

►► Available on the Packaging Series for Guaranteed Sheet Separation. This feature is required for precise counting and single shot feed on demand applications

HIGH CAPACITY FEEDING SYSTEMS WITH DYNAMIC ROTATION

Sure-Feed Packaging Feeders can be ordered standard with single shot on demand (PS) or with batch counting option (PC) in any of the series sizes from the 6" to the 18". With the batch counting option, whether your need is one piece or batch counts, the user-friendly interface lets you program your specific job requirements. The batch counter LCD screen is easy to read and set-up for your requirements. The batch mode with the auto restart option can be activated to count a pre-set amount, pause for a pre-set duration of time and then automatically feed again to maximize the output from the feeder to the application. The Packaging Series can reach speeds of 60,000 per hr.

PRODUCT TESTING

Our feeders are capable of feeding a wide range of sizes and types of materials. Send us a sample of the product you wish to feed and we will setup a demonstration video in our facility showing your product running on a specific feeder in a simulated application.

