

*PITNEY BOWES*

# **FLEXIBLE INKJET TRANSPORT**

## **36" FIT BASE: FIT-36**

### **SERVICE MANUAL**

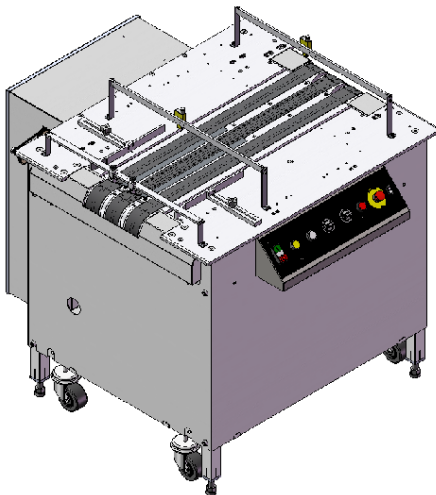

12050 49th STREET NORTH - CLEARWATER, FL. 33762-4301  
PHONE: 727.571.3330 - FAX: 727.571.3443 - TOLL FREE: 1.800.INSERTER  
web: [sure-feed.com](http://sure-feed.com)

© Copyright, Pitney Bowes Inc. 2009 All rights reserved

**VERSION HISTORY**

The table below summarizes the history of this document as it is published onto the company website(s). It identifies the version, date of issue and revisions and changes.

<b>VERSION</b>	<b>DATE</b>	<b>CHANGES</b>
FIT-36servrev0	4/24/2009	ORIGINAL RELEASE
FIT-36servrev1.2	11/16/2009	Graphics, Electrical Componets and Parameters

**REVISION CONVENTIONS-DOCUMENT**

**VERSION:** name of document with revision\_level of entire document- level designates minor changes that do not require revision change

**DATE:** date of issue for copying and publication of document.

**CHANGES:** details of document revision\_level.

## **Table of Contents**

### **Section I: Installation**

FIT 36 Base Installation	5
Orientation	6
Floor Plan and Machine Requirements	7
Environment	8
Positioning the Components	9
Electrical Setup Connections	9
Leveling the Vacuum Base	10
Electrical Cables	11

### **Section II: Safety Features and Warnings**

Safety Features and Warnings	12
Recommendations for Safe Operation	14
Special Safety Announcement	15
Lock Out Procedure	16
Suggested Lockout Devices	17

### **Section III: General Setup**

General Set Up	19
FIT 36 Set Up	20
Paper Sensor Adjustment	22
Control Panel and Switch Operation	26
Principles of Operation	31
Operating the FIT 36	31
Setting and Adjusting Run Speed	32
Adjusting Vacuum	32

### **Section IV: General Maintenance**

General Maintenance	33
FIT 36 Base Maintenance	34
General Cleaning	34
Cleaning Transport Belts/Lubrication	36
FIT36 Base Material Transport Belt Replacement	36
FIT36 Base Shaft & Roller Replacement	45

### **Section V: Electrical Components**

FIT 36 BASE Electrical Components	46
-----------------------------------	----

### **Section VI: Wiring**

FIT 36 BASE Wiring Diagrams	57
-----------------------------	----

### **Section VII: Troubleshooting**

Trouble Shooting	71
PLC Diagnostics	73

### **Section VIII: Component Programming**



Programmable Controller	75
Inverter	77

## **SPECIAL NOTES, DEFINITIONS AND DISCLAIMERS**

### **Special Note:**

Some pictures and illustrations may have color, hue and contrast graphically altered for clarity when printing in black and white and may not necessarily reflect the actual color of the product when viewed on compact disk.

## **DEFINITIONS**

1	ON
0	OFF
∅	PHASE
~	VAC (volts alterant current)
⋯	VDC (volts direct current)
!	WARNING or CAUTION
	<b>HAZARDOUS</b>
	<b>HEAT</b>

# Section I

## Installation of the FLEXIBLE INKJET TRANSPORT 36” FIT BASE: FIT-36 SERVICE MANUAL



12050 49th STREET NORTH - CLEARWATER, FL. 33762-4301  
PHONE: 727.571.3330 - FAX: 727.571.3443 - TOLL FREE: 1.800.INSERTER  
web: [sure-feed.com](http://sure-feed.com)

**Section - I**

**Orentation**

MODEL FIT 36 BASE

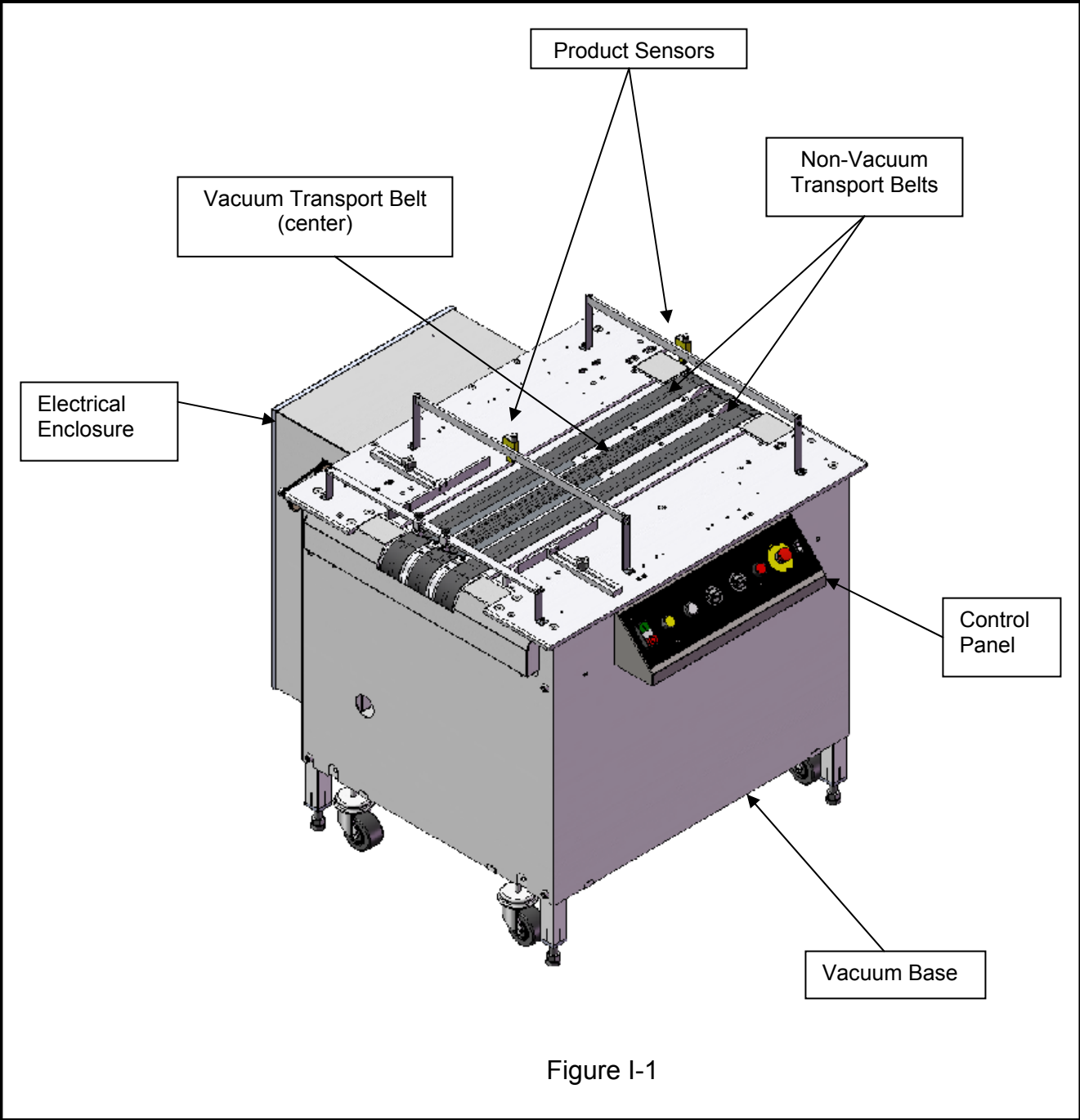
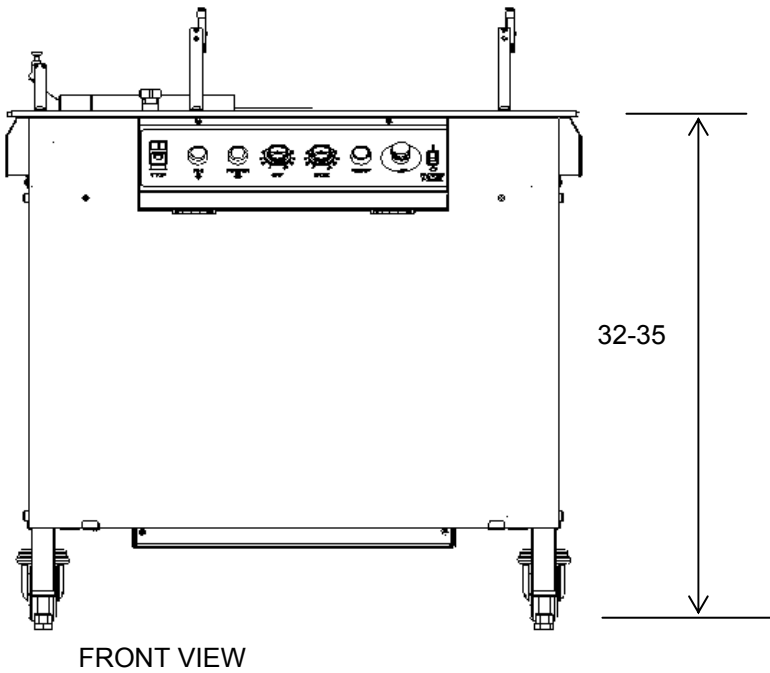
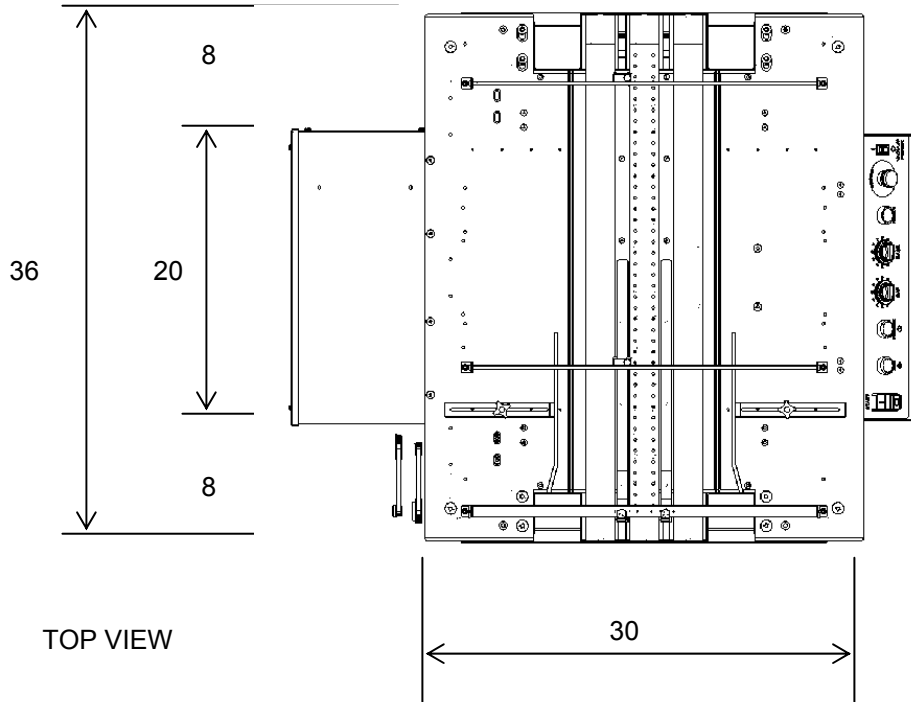

Figure I-1

**Model FIT 36 BASE  
Base Layout  
(Shown without Feeder Stand or Conveyors)**



**Requirements**

Floor Space = 7.5 sq. Ft.

Electrical = 110V~/200-240 V~, 1 PH,  
50/60 Hz, 15A/10 A

Air = None

Vacuum = None

Weight =300 #

Figure I-2

**Environment:**

The installation of the FIT 36 base is intended for operation in a specific environment. See Operating Environment Table below for details.

**Operating Environment Table**

		<b>ITEM</b>	<b>SPECIFICATION</b>	
<b>Environmental Conditions</b>	Ambient Operating Temperature		0 to 35° C	
	Storage Temperature		-25 to 85° C	
	Ambient Operating Humidity		30% to 95% RH (with no condensation)	
	Ambient Storage Humidity		5% to 95% RH (with no condensation)	
	Pollution Level		Pollution level 2 (conforming to UL/EN60950-1)	
	Corrosion Gas		There must be no combustible or corrosive gas.	
	Operating Altitude		2,000 m above sea level or lower, Air Pressure 86 kPa to 106 kPa	
	Radiation		Should not exceed tolerable levels other than associated with UV dryer lamps	
	Vibration		Not Applicable	
	<b>Installation Requirements</b>			
Ground			Ground (earth) connection required	
Cooling Method			Natural cooling	



## Installation: Positioning the Components

Once the FIT 36 base has been removed from the shipping container, perform the following:

1. Inspect the location where the machine is to be set up.  
(Note: The manufacturer recommends that the area be a relatively flat and smooth concrete or hard wood surface, similar substrates are acceptable. The area should be free of holes, divots, loose floorboards, etc. and not subject to retaining moisture from water seepage.) (Warning: In the event the floor does not meet the recommended requirements, seek an alternate location or reschedule the installation after repairs to the floor have been completed)

## Installation: Electrical Setup Connections

2. Inspect the line current at the point where the power cable of the machine is to be plugged in. (Note: Conventional wall sockets, ceiling line drops and D-Boxes should be free of cracks, rust, visible signs of heat stress and flash marks.) (Special Note: For installations in Europe check the condition of the voltage converter box or other voltage reducing device that may be in use. In the event of a line voltage inspection failure, report your findings to the person or persons in charge of the building and postpone the installation until corrections are made.)
3. Check the line voltage to ensure that the minimum and maximum requirements are present.
4. Check to see what volt value the transformer (located in electrical enclosure) is pinned out to at the voltage selection block, see figure I-3. If the volt value is different from the line voltage you checked in step 3, the transformer will need to be re-configured to match.

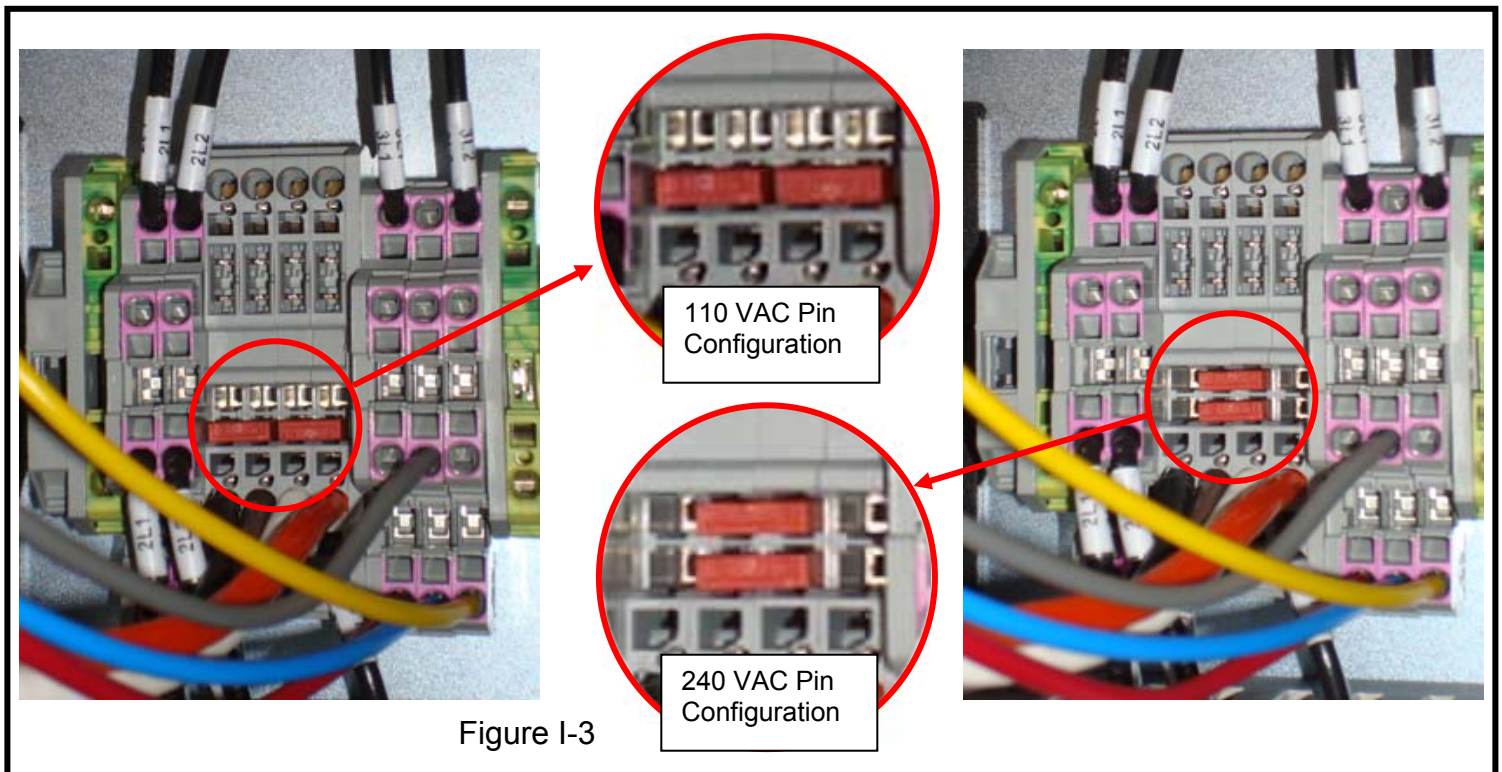
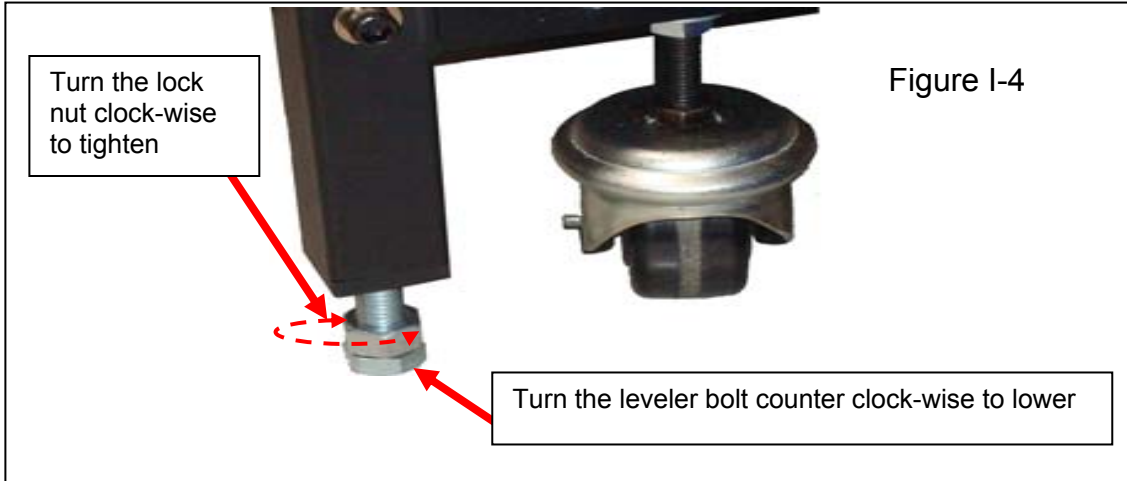

Figure I-3

**Installation: Leveling the FIT 36 Base**

- 5. Position the FIT 36 base in the designated location then lower the leveler pads to raise the base to a comfortable operating height. See figure I-4.



- 6. Place a level in the center of the FIT 36 base and adjust the leveler pads as needed to level the machine at the desired height. Once the machine has been leveled, tighten the leveler pad lock nuts, see figure I-5.

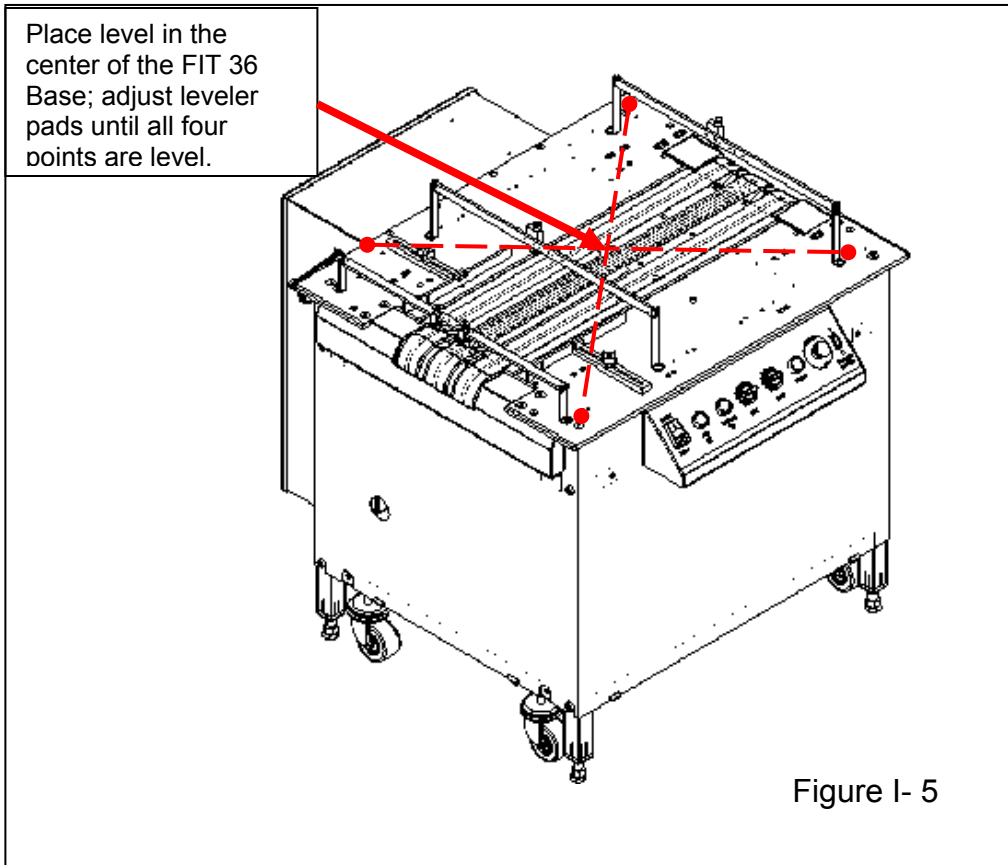

**Installation: Electrical Cables**

- 7. Plug the in-feed conveyor (or feeder) cable into the J1 receptacle located on the RH side panel of the FIT 36 electrical enclosure. See figure I-6.

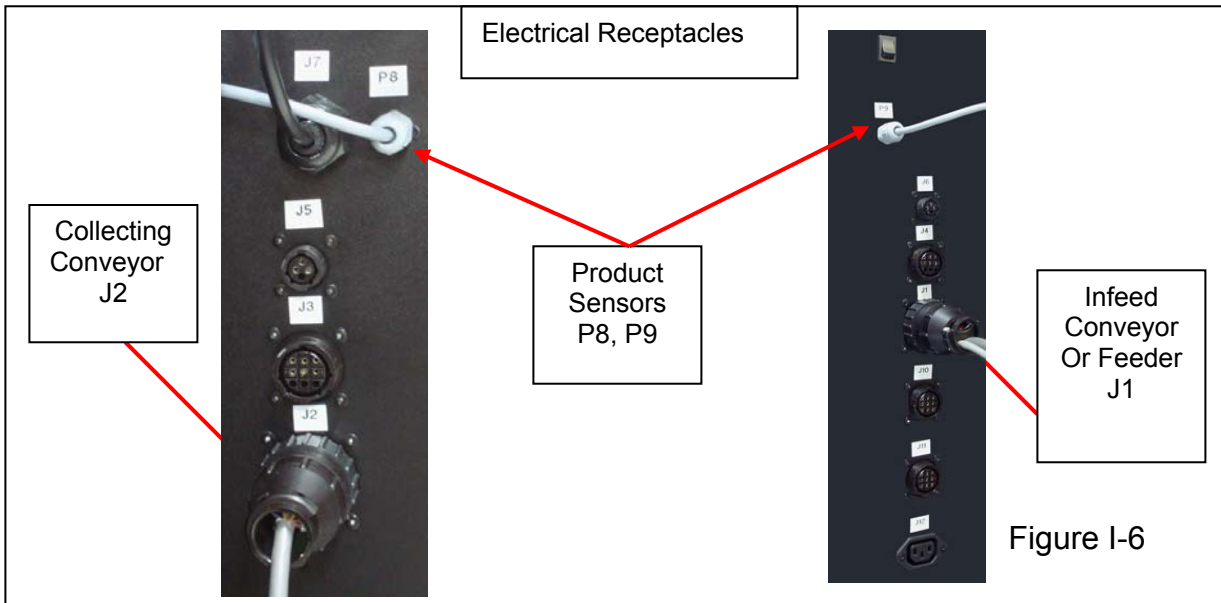

- 8. Plug the collecting conveyor cable into the J2 receptacle located on the LH side panel of the FIT 36 electrical enclosure. See figure I-6.
- 9. Plug the gray sensor cables (P9 and P8, respectively) into the upstream and downstream receptacles located on the FIT 36 electrical enclosure.

# **Section II**

## **Safety Features & Warnings**

### **SERVICE MANUAL**



***DIRECT MAIL SOLUTIONS***

12050 49th STREET NORTH - CLEARWATER, FL. 33762-4301  
PHONE: 727.571.3330 - FAX: 727.571.3443 - TOLL FREE: 1.800.INSERTER  
web: [sure-feed.com](http://sure-feed.com)

## Section- II

### Safety Locks and Warnings:

All covers (panels) to cabinets containing moving parts and electrical components are attached with Allen head screws that require the use of an Allen wrench to open.

All FIT 36 bases are provided with caution or warning labels or stickers to safeguard persons operating and or working on or around this equipment. These are as follows:

**General Warning**  
Symbol indicating possible safety hazards.  
Found posted on the front service panel of the  
FIT 36 Base.

Figure II-1



*Label shown at actual size*

**Shock Hazard**  
Symbol indicating possible shock hazard.  
Found posted on the service cover on the  
electrical enclosure mounted on the  
backside of the FIT 36 Base.

Figure II-2



*Label shown at actual size*

**Mechanical Warning**  
Symbol indicating pinch hazard. Found posted  
on the mounting plate of the transport belt drive  
motor.

Figure II-3



*Label shown at actual size*

**Burn Warning**  
Symbol indicating burn hazard. Found posted  
on the dryer.

Figure II-4



Note: This symbol  appears as a visual alert in the text of this manual next to written warnings regarding possible safety issues and or possible machine damage that may occur as a direct result of failure to follow specific instructions as written.

## **Recommendations for Safe Operation**

(Note: The safety devices, warning labels and stickers are installed by the manufacturer to safeguard all persons operating and or working on or around the FIT 36. Removing, altering or disabling any of these items will void any and all warranties, either real or implied, purchased or offered with the (FIT 36). All companies connected with the manufacturing, promotion and sale of the (FIT 36) shall be held harmless for any and all injuries and damage in the event the safety devices, door locks, warning labels and stickers are removed, altered or disabled)

In addition to the safety devices and warnings installed on the (FIT 36) by the manufacturer, the following recommendations for safe operation and maintenance of the (FIT 36) are as follows:

- Any persons designated to operate, work on or near the (FIT 36) must be fully trained by a factory-authorized representative.
- Do not operate or perform any type of maintenance on the (FIT 36) while under the influence of drugs or alcohol.
- Do not operate or perform any type of maintenance on the (FIT 36) in or around freestanding water.
- Do not wear loose fitting shirts, shirts with billowing sleeves, bracelets, rings, necklaces, neckties or other loose apparel that may come into close proximity with moving parts of the machine.
- Do not place any items near or over the “Emergency Stop Switches” that might inhibit or obstruct line of sight or access to the Emergency Stop Switches. The “Emergency Stop Switches” must be clearly visible and accessible at all times.
- Wear protective safety eyeglasses or goggles and use a particle mask or similar device when cleaning off the (FIT 36) with compressed air. Alert all other persons in the area to stand a minimum of thirty (30) feet from the area where compressed air is put to such use.
- Hearing protection is not required for safe operation of the (FIT 36). Typically, decibel levels have been found to be less than 85 decibels in machines properly maintained and in good operating condition.
- All persons having hair greater than shoulder length who operate, work on or near the (FIT 36) should keep their hair pulled back in ponytail fashion then pinned up or otherwise contained to the top of their head or confined under the back of their shirt.
- Turn off the main power to the (FIT 36) before opening any of the service panels for general cleaning and or general maintenance. Follow the “Lock Out Procedures” as stated on page 16 for extensive repairs involving disassembly of the machine either in whole or in part or replacing any of the electrical components.
- Any persons working near any of the electrical motors or pump motors of the (FIT 36) should use caution. Electrical motors give off heat, contact with or exposure to bare skin may result in burns.
- The (FIT 36) was designed to feed and transport paper only. Do not attempt to feed and / or run materials made of or containing glass, metal, wood, liquids, foods, powders, gasses, explosives or toxic and hazardous chemicals on the (FIT 36). (Note: The manufacturer and other companies connected with the promotion and sale of the (FIT 36) do not assume any responsibility for any damage to the (FIT 36) or product and shall be held harmless for any damages and or injuries sustained to person or persons resulting in this practice.)

**Special Advisement:**

The manufacturer and all other companies connected with the promotion and sale of the (FIT 36) shall be held harmless for any and all injuries sustained to any person or persons as a result of failure to comply with the recommendations for safe operation and maintenance of the (FIT 36) as shown and / or described herein.

The Lithium batteries used in our products may contain Perchlorate Material --- special handling may apply.  
See [www.disc.ca.gov/hazardouswaste/perchlorate](http://www.disc.ca.gov/hazardouswaste/perchlorate).

If any equipment is provided with a replaceable battery and if replacement by an incorrect type could result in an explosion (for example, with some lithium batteries), the following applies:

- If the battery is placed in an 'operator access area', there shall be a marking close to the battery or a statement in both the operating and servicing instructions;
- If the battery is placed elsewhere in the equipment, there shall be a marking close to the battery or a statement in the servicing instructions.

This marking or statement shall include the following or similar text:

**CAUTION**

**RISK OF EXPLOSION IF BATTERY IS REPLACED BY AN INCORRECT TYPE**

**DISPOSE OF USED BATTERIES ACCORDING TO THE INSTRUCTIONS**

## **Section- II**

### **Lock Out Procedure**

Before beginning extensive repairs involving disassembly of the machine either in whole or in part, performing general maintenance or replacing any of the electrical components, the machine must be locked out of service to ensure that power will not be restored to the machine while the work is being performed. To lock a machine out of service, perform the following:

 **Warning:** The following procedure is published herein for the expressed purpose of providing a safe work environment conducive to persons performing repairs and or maintenance and or general cleaning of the (FIT 36) and or any other components connected to or associated with the (FIT 36). This procedure must be followed without exception to ensure the safety of any person or persons performing the previous stated task.

The manufacturer and other companies connected with the promotion and sale of the (FIT 36) shall be held harmless for any and all injuries sustained to any person or persons and or damage to the (FIT 36) and or any other components connected to or associated with the (FIT 36) as a result of failure to comply with the "Lock Out Procedure".

1. Turn the main power switch to the off position.
2. Disconnect the power cable from its source by performing the following:
  - a. Follow the main power line from the machine back to the receptacle or source of supplied power and disconnect it at the source.
  - b. Place the plug connector close to the machine in such a position that will remain in your field of vision while repairs or maintenance is being performed.
3. Notify all other persons in the area where the work is being performed that the machine will be out of service, especially if the work you are performing requires you to be crouched behind or beside the machine or in some other way obscured from the sight of other persons in the area.
4. When the work has been completed reconnect the plug to the power source and then test cycle the machine to ensure that power has properly restored and the machine is fully functional.
5. Notify all other persons in the area that the machine is fully operational and that the drive motors will become enabled when the power switch is placed in the on position.



**Suggested Lockout Devices**

The following are some suggested devices specifically designed to provide a greater degree of safety when locking out the power supply to a machine. These devices can be purchased from most safety equipment suppliers and vendors.

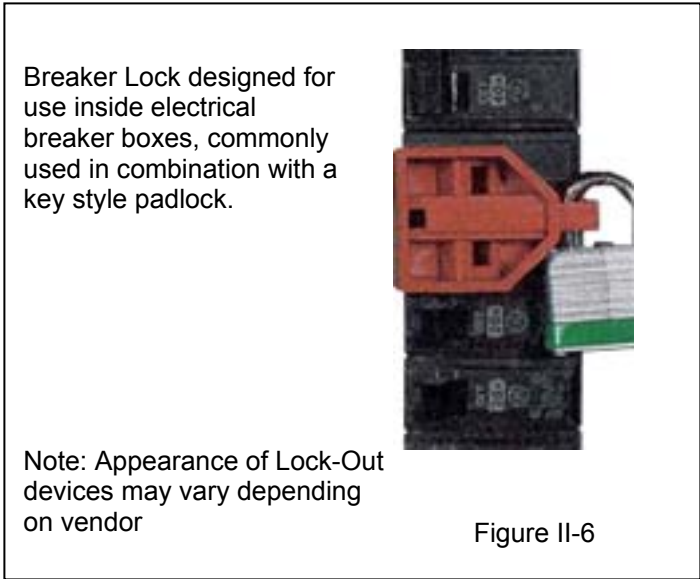
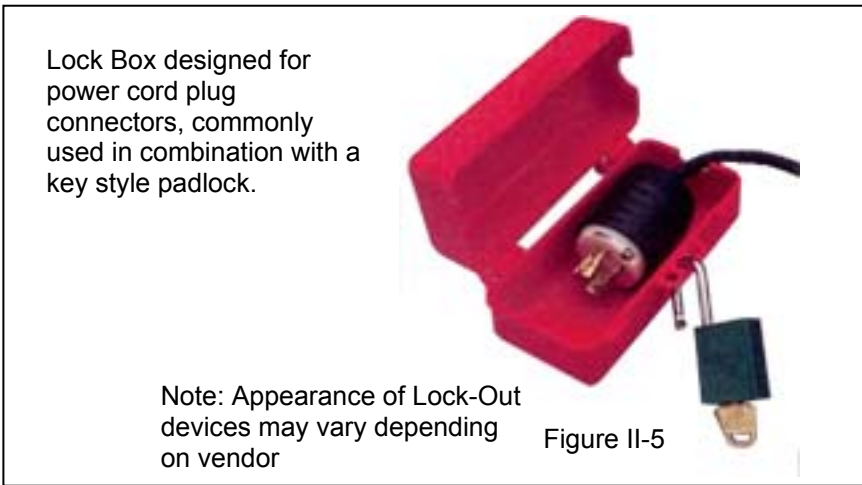

Warning Alert tags, commonly used in combination with all lock out devices.



Figure II-7

# **Section III**

## **General Set-Up**

### **FLEXIBLE INKJET TRANSPORT 36" FIT BASE: FIT-36 SERVICE MANUAL**



***DIRECT MAIL SOLUTIONS***

12050 49th STREET NORTH - CLEARWATER, FL. 33762-4301  
PHONE: 727.571.3330 - FAX: 727.571.3443 - TOLL FREE: 1.800.INSERTER  
web: [sure-feed.com](http://sure-feed.com)

**Section - III**

This (FIT 36) is designed to run off line or in line with most feeders, FlowMaster inserters, FIT bases, FIT diverters and numerous conveyors. These manuals can be obtained through your local Sales Representative or Dealer.

**(FIT 36) Setup**

1. Fold one (1) piece of material in half to establish a center crease. (Note: The crease needs to be made in the direction of travel that the material is to be run, see figure III-1.)

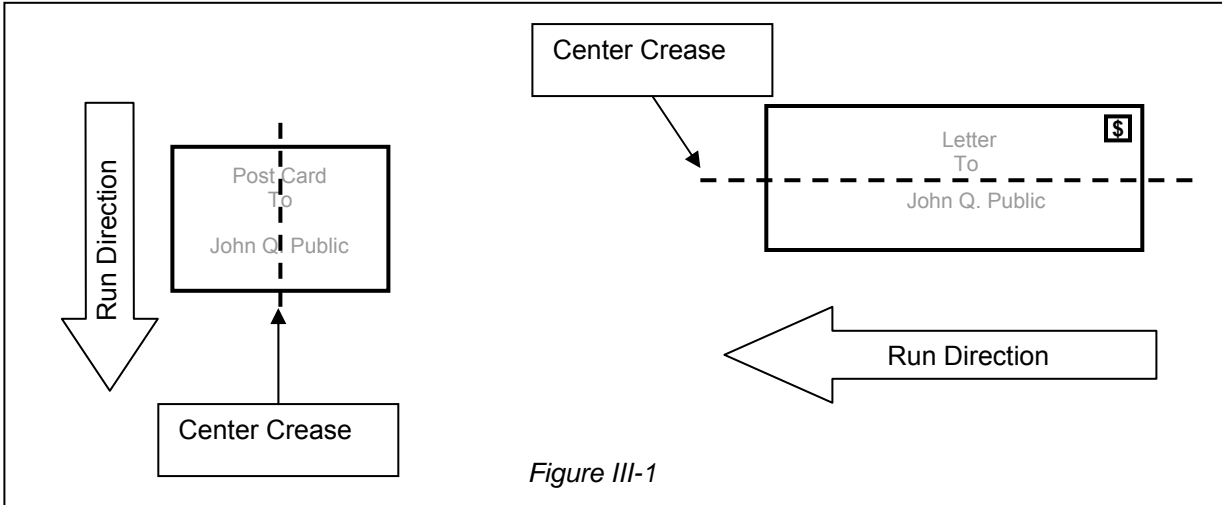

Figure III-1

2. Align the center crease of the set up piece with the center of the vacuum transport belt (belt with holes), see figure III-2.
3. Set the width of the material guides located on the transport deck by turning the retaining knobs in a counter clock-wise direction to loosen, clock-wise direction to tighten. Adjust the material guides to center the material being run onto the vacuum belts, see figure III-2. (Note: Arrange the guides approximately 1/16" from the top and bottom edge of the material to prevent restricting the material on the transport belt.)

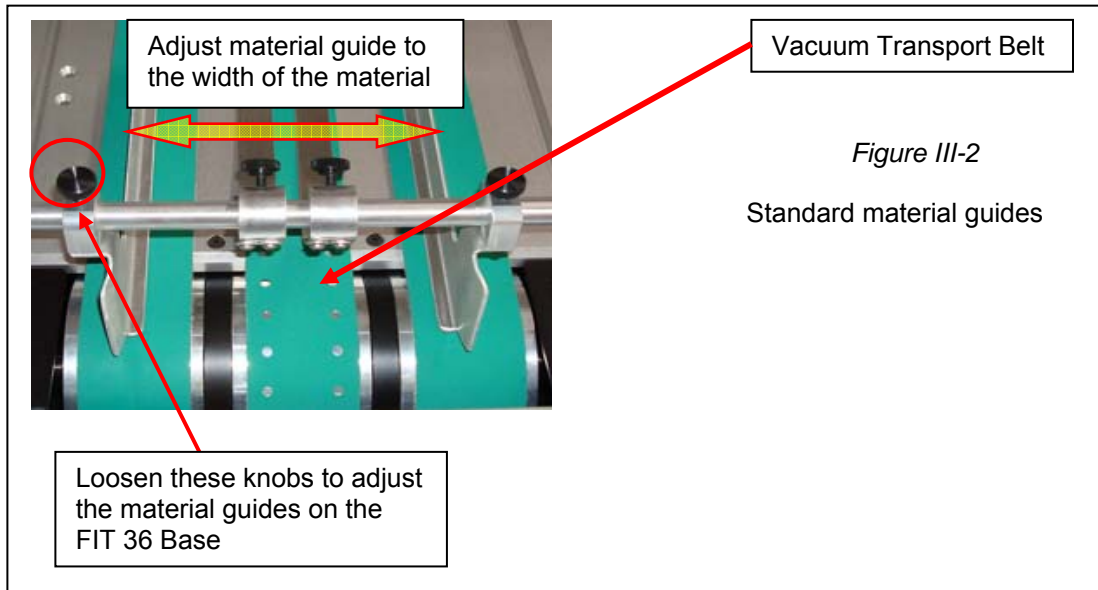
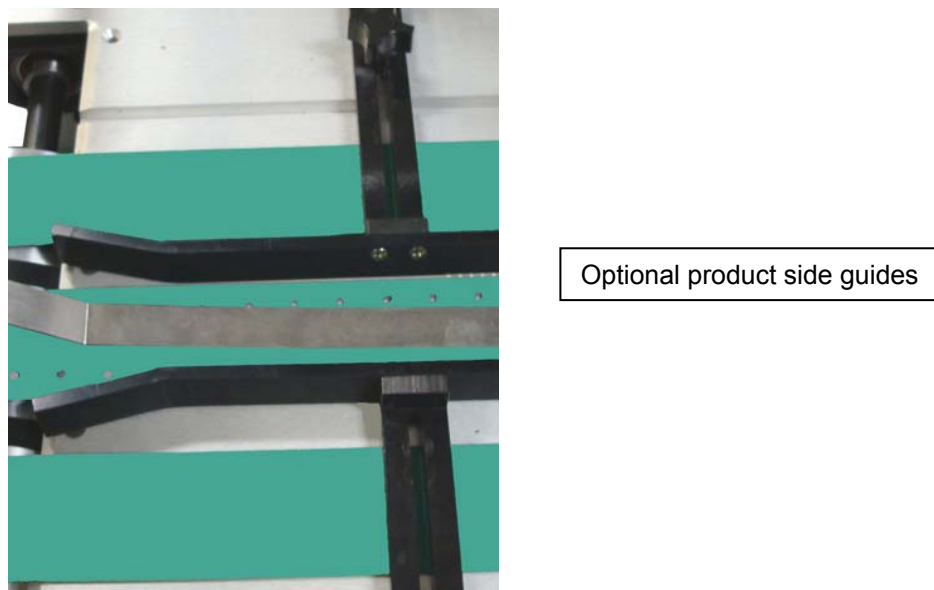
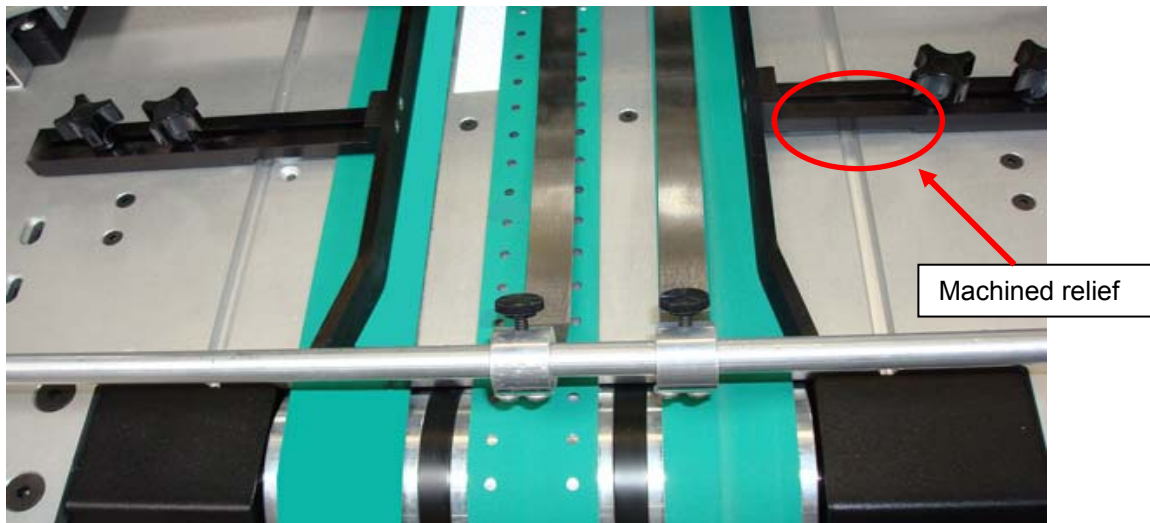

Figure III-2

Standard material guides

4. Setting the width of the material guides located on the transport deck for narrow products. If the product is narrower than the existing overall belt set width, it will be necessary to move the standard material guides to the outermost position on the crossbar and use optional product side guides. See figure III-3.
  - a. Turning the retaining knobs in both material guides in a counter clock-wise direction to loosen and slide material guides to each end of the crossbar.
  - b. Place new product side guides onto top plate and attach each using a hand knob. NOTE: A machined relief is on each product side guide to provide clearance for outer non-vacuum belts. See figure III-3.



*Figure III-3*

## Paper Sensor Adjustment: Reflective and Diffuse

The paper sensor is located at the “In-Feed” end of the FIT 36’s vacuum base, over the center vacuum belt. This sensor is set to detect and confirm the presence of paper before passing under various attached components (ie ink jet heads). This sensor does not normally need to be adjusted for each job, once the setting has been made, it should remain set unless otherwise disrupted. In the event the settings have been disrupted, perform the following:

### REFLECTIVE

1. Position the sensor directly over the center of the reflective tape (located on conveyor top plate) and attach the sensor to the sensor support bar using the two (2) outermost tapped holes.
2. Place a blank piece of white paper on the vacuum belt directly under the paper sensor.
3. Using a small flat blade screwdriver, remove the pan head screw in the plastic cover located on the sensor next to the electronic cable connection, see figure III-4 (Note: This sensor will have a detachable screw type cable connection.)
4. Set the “Light / Dark” pot setting; using a small flat blade screw driver, slowly and very carefully turn the pot setting, located next to the electronic cable connection, in a counter clock-wise direction until full range of motion is felt, see figure III-5. (Note: If this adjustment is performed correctly, the screw driver slot in the pot setting should be pointing towards the “DO” in the range scale next to the pot setting.)



**(Caution:** The stop point of this pot setting can be damaged if excessive force is applied.)

5. Set the “Gain” pot setting by performing the following;
  - A. Using a small flat blade screw driver, slowly and carefully turn the pot setting located furthest from the electronic cable connection, in a counter clock-wise direction until full range of motion is felt, see figure III-5. (The red LED indicator light should be off at this point.)
  - B. Using a small flat blade screw driver, slowly and carefully turn the pot setting located furthest from the electronic cable connection, in a clock-wise direction until the red LED light comes on, continue turning the pot setting in a clock-wise direction another half turn.
6. Return the plastic cover, removed in step (3) to its original position.

**DIFFUSE**

1. Position the sensor directly over the center of the middle vacuum belt and attach the sensor to the sensor support bar using the two (2) center tapped holes.
2. Place a blank piece of white paper on the vacuum belt directly under the paper sensor.
3. Using a small flat blade screwdriver, remove the pan head screw in the plastic cover located on the sensor next to the electronic cable connection, see figure III-4 (Note: This sensor will have a detachable screw type cable connection.)
4. Set the “Light / Dark” pot setting; using a small flat blade screw driver, slowly and very carefully turn the pot setting, located next to the electronic cable connection, in a counter clock-wise direction until full range of motion is felt, see figure III-6. (Note: If this adjustment is performed correctly, the screw driver slot in the pot setting should be pointing towards the “LO” in the range scale next to the pot setting.)

**!** (Caution: The stop point of this pot setting can be damaged if excessive force is applied.)

5. Set the “Gain” pot setting by performing the following;
  - A Using a small flat blade screw driver, slowly and carefully turn the pot setting located furthest from the electronic cable connection, in a counter clock-wise direction until full range of motion is felt, see figure III-6. (The red LED indicator light should be off at this point.)
  - B Using a small flat blade screw driver, slowly and carefully turn the pot setting located furthest from the electronic cable connection, in a clock-wise direction until the red LED light comes on, continue turning the pot setting in a clock-wise direction another half turn.
6. Return the plastic cover, removed in step (3) to its original position.

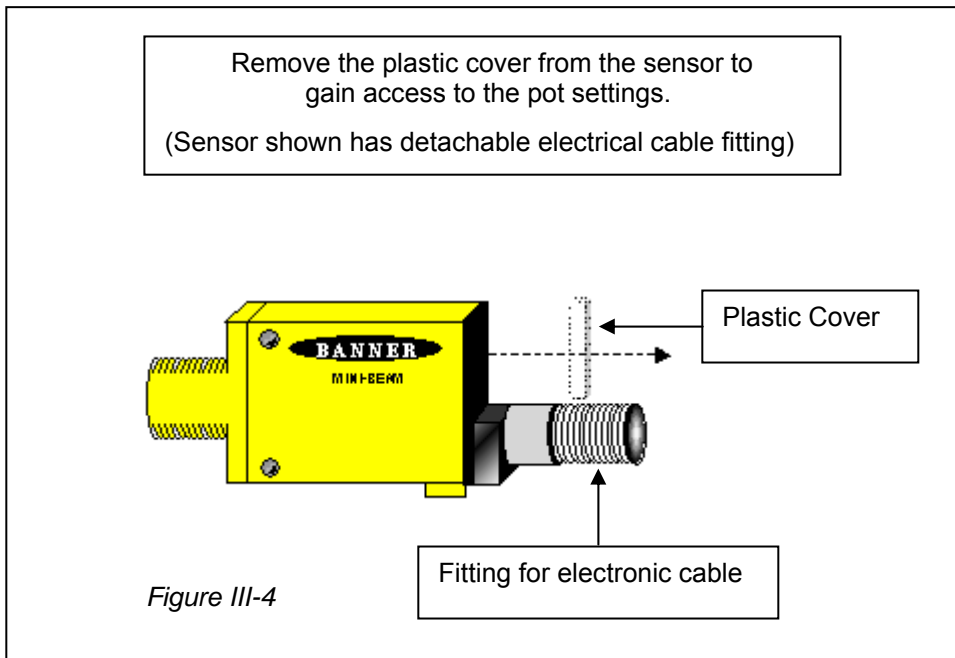

REFLECTIVE

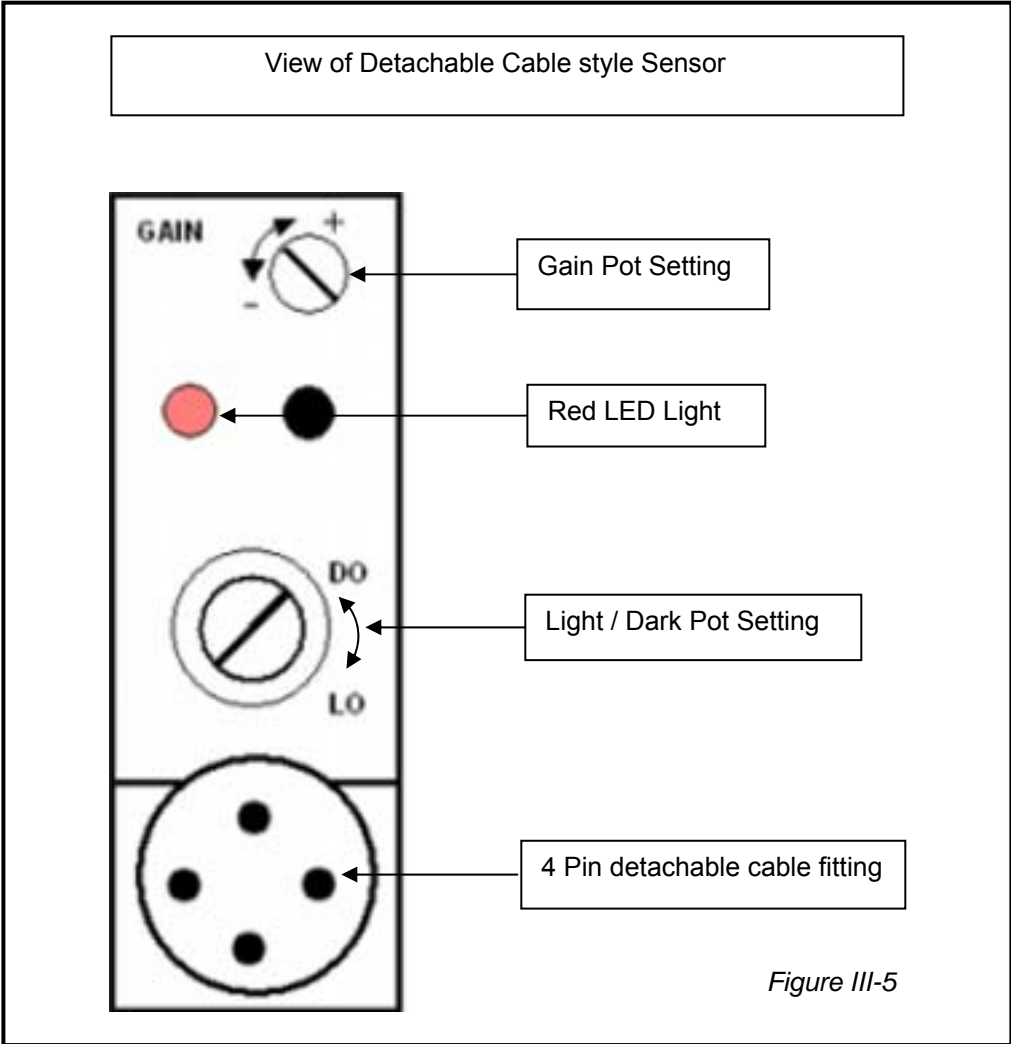



**DIFFUSE**

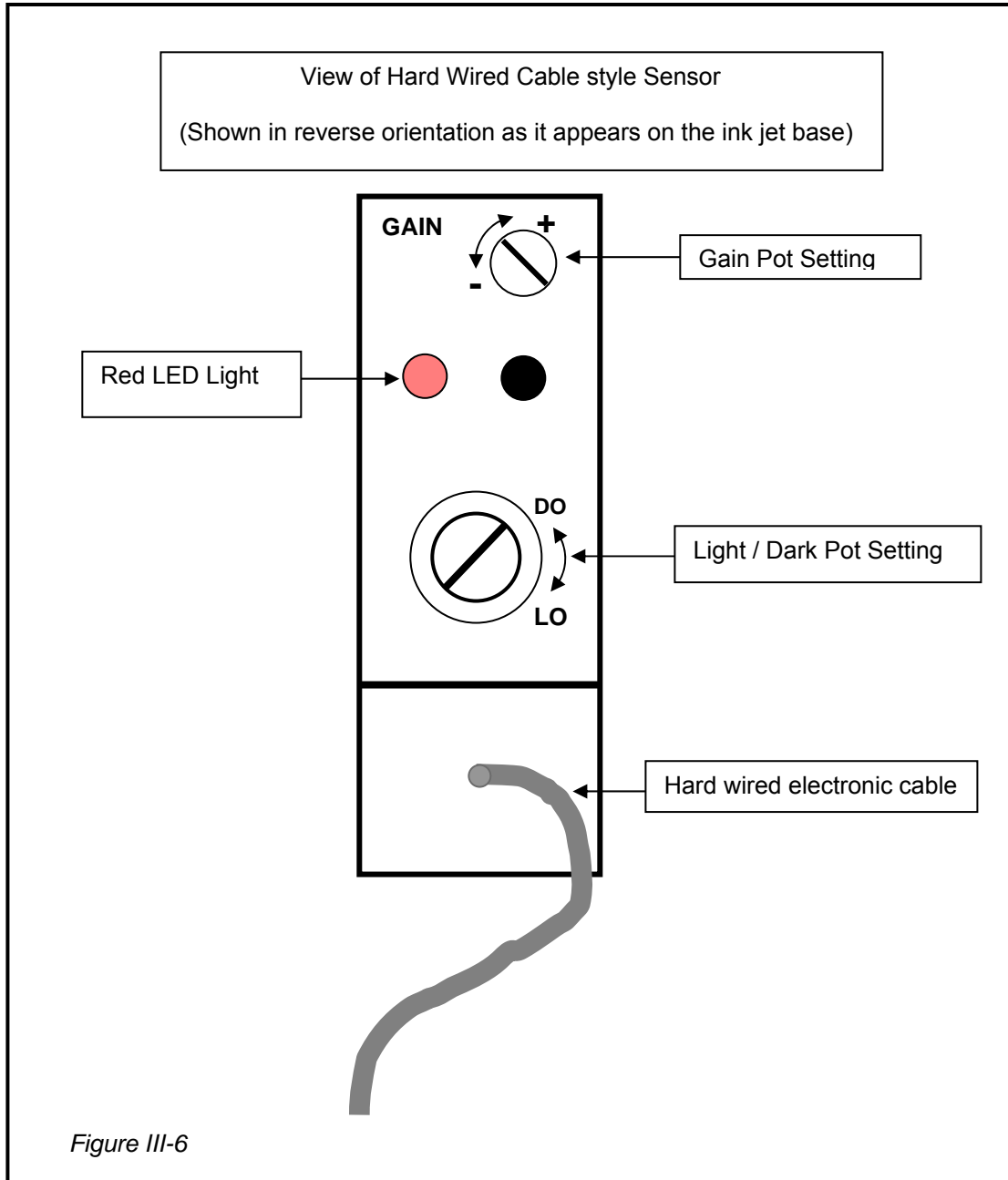

Figure III-6

FIT 36 BASE Operator Control Panel

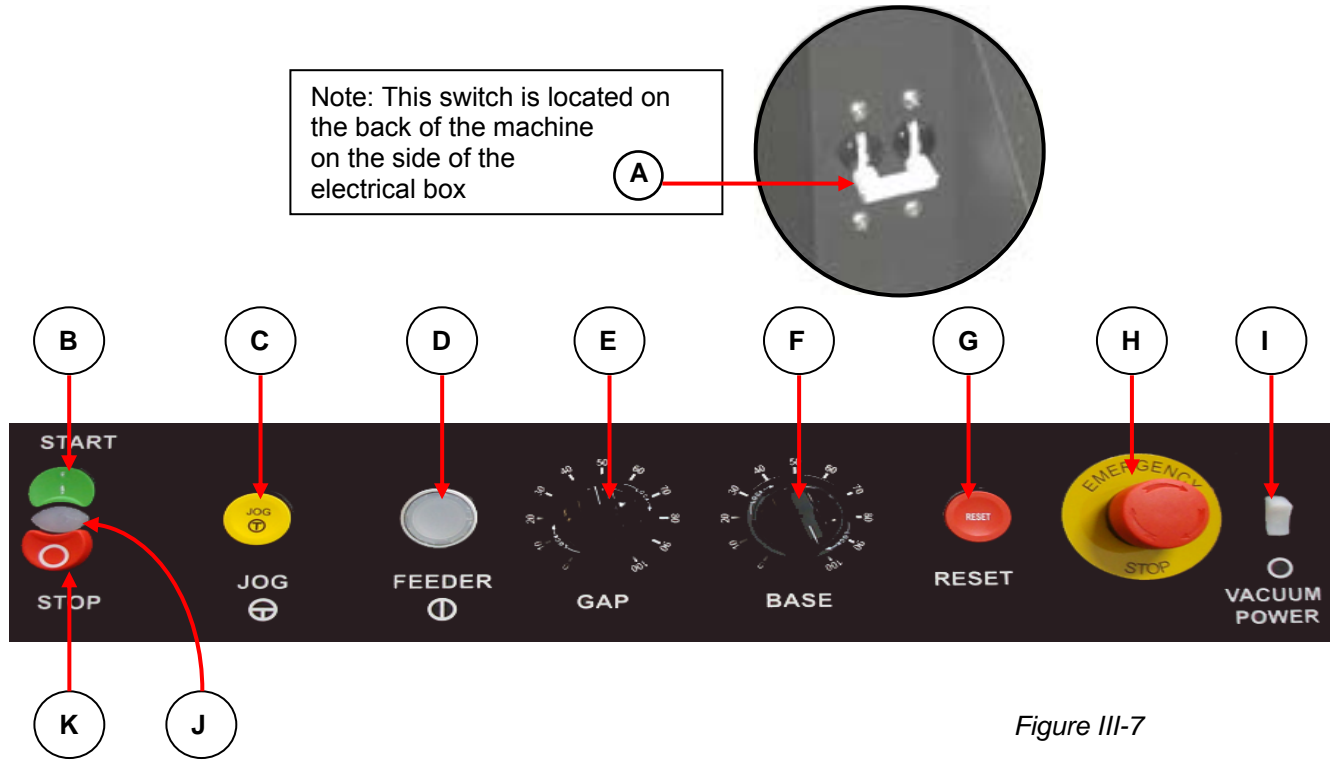
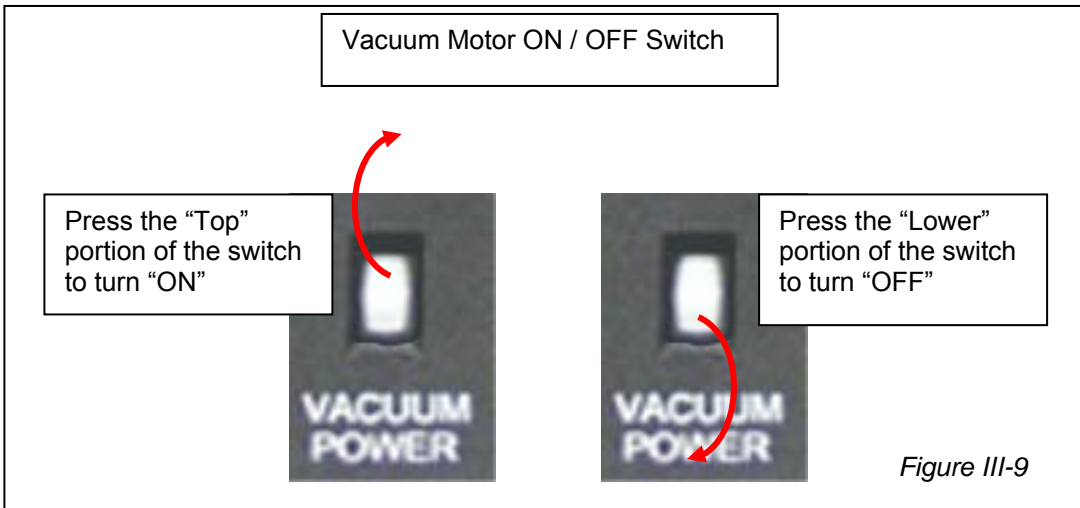
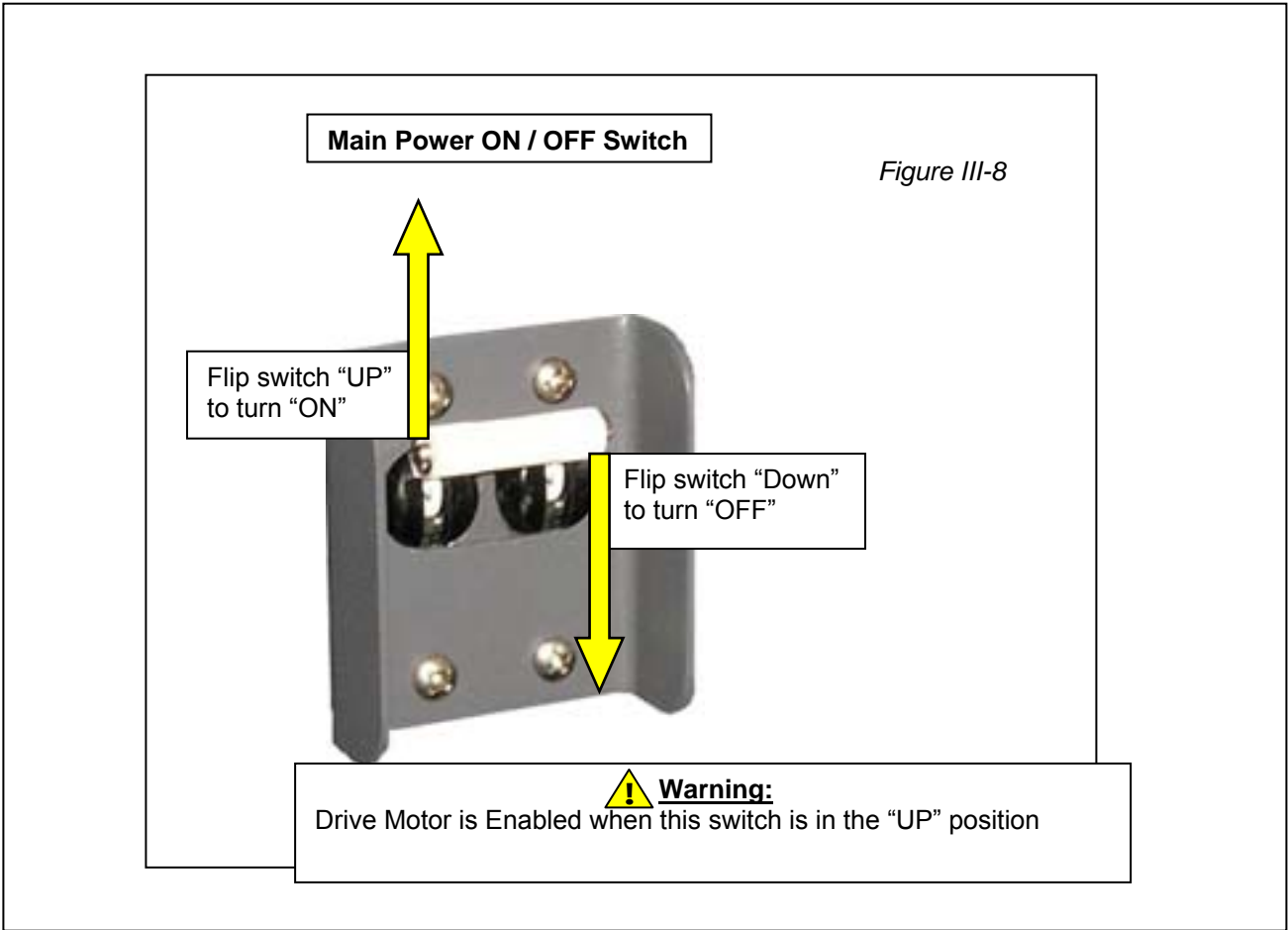
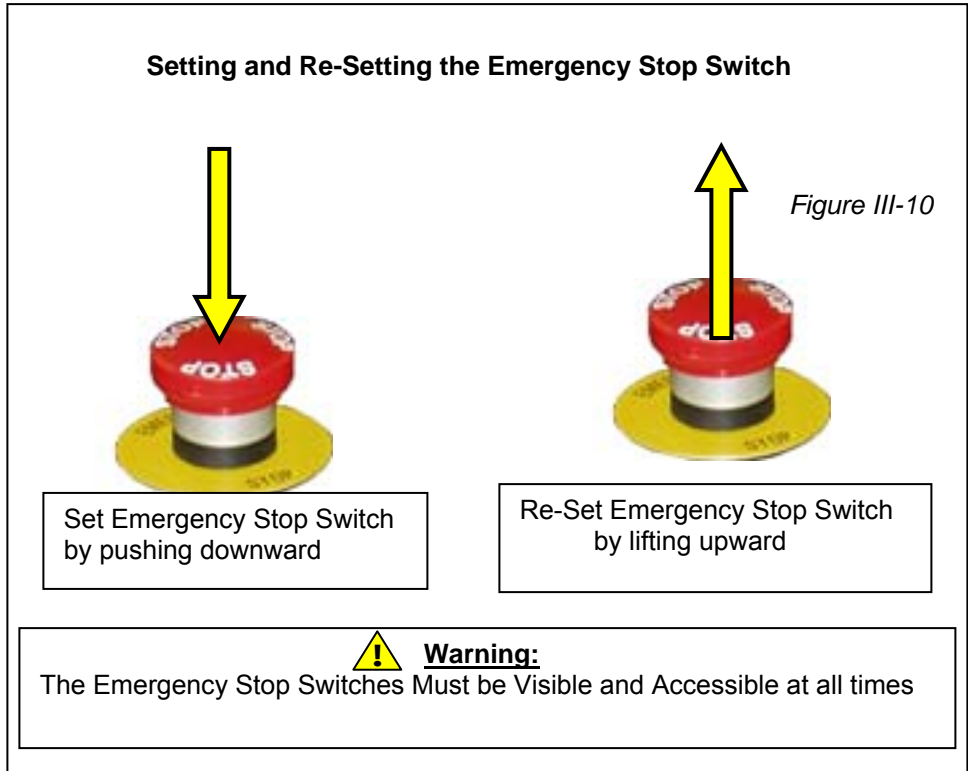

Figure III-7

Item	Description	Function
A	Main Power Switch	Engages Power to the machine (electrical enclosure)
B	Start Switch	Initiates power to cycle base
C	Jog Button	Cycle all components of machine while pressed
D	Feeder Button	Engages Power to Feeder
E	Gap Control Dial	Increases and decreases speed of Feeder
F	Bas Control Dial	Increases and decreases speed of base
G	Reset Button	Resets any Corrected Fault
H	Emergency Stop Button	Interrupts power to all components of the machine
I	Vacuum Power Switch	Engages power to the vacuum pump
J	LED Indicator	Indicates Status of Base Steady Light=No Fault, Slow Flashing = Photo-Eye Fault, Quick Flashing = Print Head Fault
K	Stop Switch	Interrupts power to Base





Special Note: Pursuant to Community Legislation on Machinery, Comments on Directive 98/37/EC 1.2. Controls and 1.2.1 Safety and reliability of control systems

The “E-Stop” button / buttons found on the FIT 36 vacuum base are by design in compliance to meet and / or exceed the mandates and requirements as stated in the Community Legislation on Machinery, Comments on Directive 98/37/EC.

By manufacture design the E-Stop buttons are to be used in the event of an emergency, once the E-Stop button has been depressed, it must be physically re-set.

For a selective stop to interrupt normal machine operation, depress the “Red” control Stop button. The machine can be re-started without delay at the operator’s discretion.

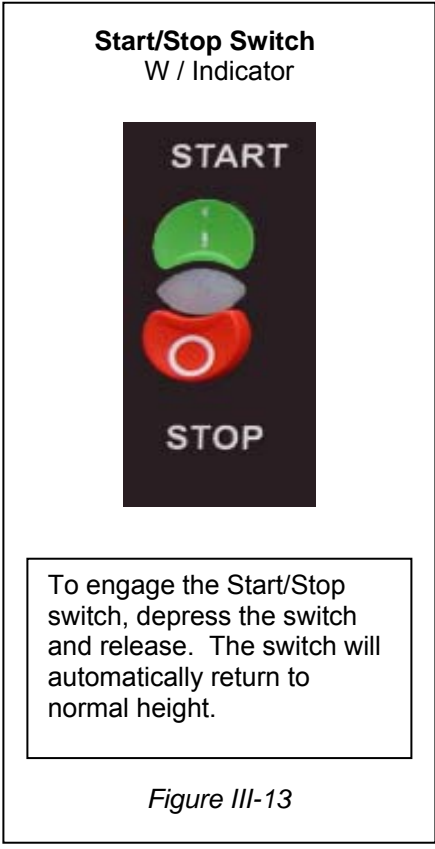
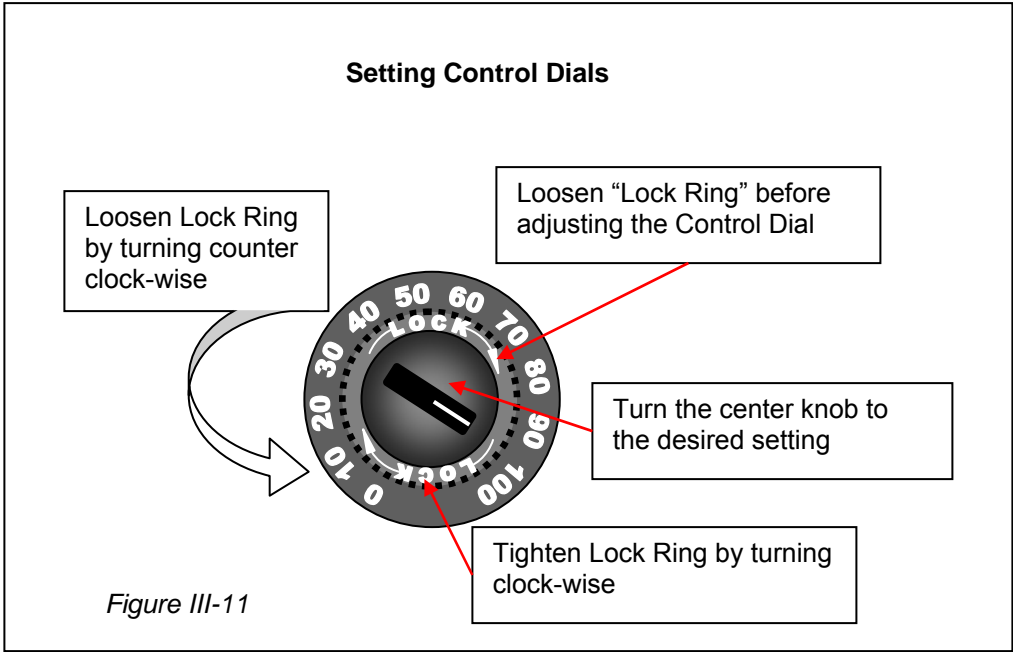

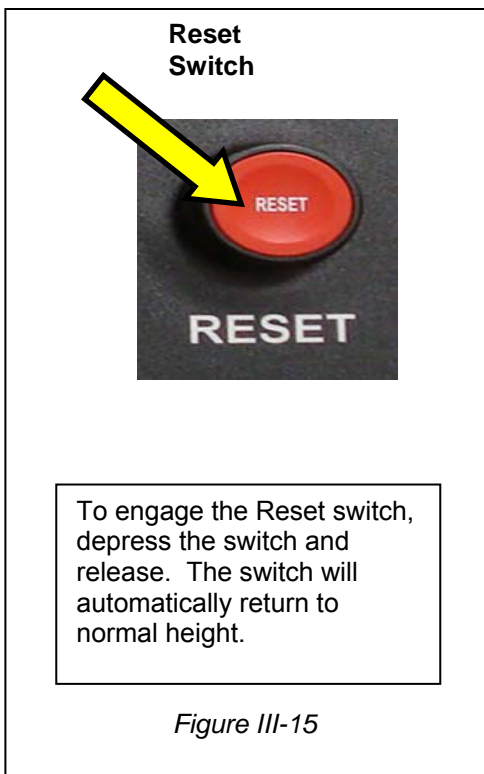
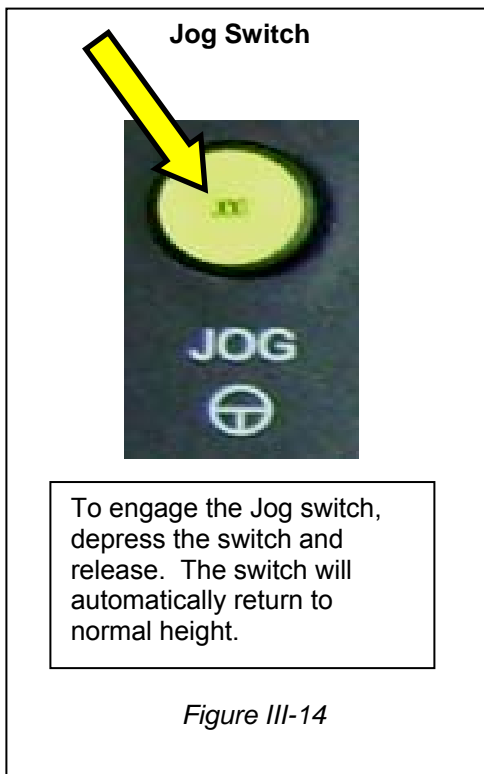

**Print Heads**

If print heads are included or are to be attached to the vacuum base, set up the print heads in accordance with the manufacturer specifications.

## **PRINCIPLES OF OPERATION**

The manually operated switches and potentiometers are provided to co-ordinate the operation of various components. An example of a basic machine consists of a feeder, the FIT 36 base and a collecting conveyor.

1. The FEEDER ON/OFF switch only enables the feeder- other (start/stop, jog and reset) switches permit the feeder's operation in parallel with the base conveyor.
  - a) STOP: Controls the stop circuits of VFD 1(leader) for the base conveyor motor & DC DRIVE (follower) for the feeder belt motor.
  - b) JOG: A PLC programmed set speed of base conveyor motor and feeder belt conveyor-control is used for product set-up.
  - c) RESET: Returns the machine to operating condition after an E-STOP condition.
2. BASE potentiometer- the "leader" speed control input for the base conveyor VFD. The VFD will output a signal to the feeder (or upstream component) to permit parallel operation (the feeder motor will "follow" the "leader" base conveyor motor). If any modification is needed to produce a different separation distance between conveyed product pieces, refer to GAP potentiometer.
3. GAP potentiometer- the "follower" speed control input for the feeder motor only. An increase in speed (higher potentiometer setting) produces a shorter separation distance (gap) between conveyed product pieces. Larger gaps occur when the potentiometer is set lower.
4. VACUUM switch-energizes the vacuum pump motor.

## **Operating the (FIT 36)**

### **Power:**

1. Turn power to the machine on by placing the white power switch, located on the electrical enclosure, in the up position. See figure III-8.

### REFERENCE: CONTROL CONSOLE

2. Check E-STOP, pull up to release.
3. Press red RESET pushbutton to illuminate white led indicator on START-STOP pushbutton or to 'clear' E-STOP condition, see figure III-15.
4. Turn the vacuum pump motor on by depressing the upper half of the white switch until it lights up, see figure III-9.
5. Press white FEEDER pushbutton to operate feeder with conveyor, see figure III-12.  
Note: Feeder must have sufficient product.
6. Press and hold the yellow JOG pushbutton located on the control panel to jog the machine forward until one (1) piece of material has been fed from the feeder onto the material vacuum transport belts of the FIT 36 vacuum base, see figure III-14.
7. Press green START pushbutton to initiate feeder/conveyor operation. White led will be steady. Please note that operation will cease automatically (a time out condition) if product is not sensed at leading sensor and white led will produce a slow flash condition.

**NOTE: RED RESET PUSHBUTTON MUST BE PRESSED TO 'CLEAR' E-STOP CONDITION !!**

# PITNEY BOWES

- 8. Press green START AND yellow JOG pushbuttons simultaneously to by-pass “feeder out of paper” condition (conveyor will operate continuously until first product is sensed at leading sensor-then step 7 conditions prevail).
- 9. If white led produces a fast flash condition then a paper jam has occurred at either leading or trailing sensor (a paper jam is normally caused when more than one product is being sensed, i.e. overlapping pieces). Clear jam and re-start.

## Setting Run Speed

- 1. Once the material is being transported by the vacuum transport belt (green START button is active and LED indicator is steady), adjust the speed of the FIT 36 base by turning the Base Speed Control Knob in a clock-wise to increase the speed or counter clock-wise to decrease the speed, see figures III-11. (Note: Set the speed to best accommodate the material and fonts being run.)
- 2. Set the FEEDER gap by adjusting the Gap Control knob in a clock-wise direction to shorten the gap between each piece of material as it feeds or counter clock-wise to increase the gap between each piece of material as it runs, see figure III-11.

## Adjusting level of vacuum

Normally there is no need to adjust the vacuum level available at the perforated vacuum transport belt between different products. However, if the product is subject to damage from standard vacuum levels, there is vacuum adjustment valve available to decrease the overall vacuum available to an appropriate level. This valve is located inside the machine between the pump motor and the back cover, see figure III-15.

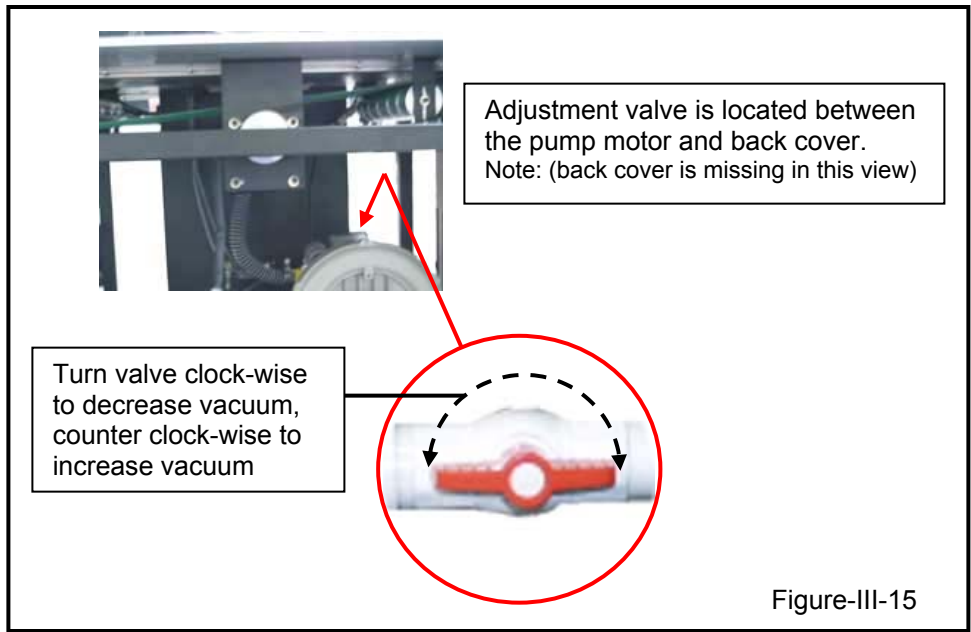



# Section IV

## General Maintenance & Service

### FLEXIBLE INKJET TRANSPORT 36" FIT BASE: FIT-36 SERVICE MANUAL



***DIRECT MAIL SOLUTIONS***

12050 49th STREET NORTH - CLEARWATER, FL. 33762-4301  
PHONE: 727.571.3330 - FAX: 727.571.3443 - TOLL FREE: 1.800.INSERTER  
web: [sure-feed.com](http://sure-feed.com)

## Section - IV

### FIT 36 Base Maintenance:

The general maintenance of the FIT 36 base is limited due to the design and materials used in manufacturing. The frequency of general cleaning required for the FIT 36 is dependent on the amount of running time put on the machine.

### General Cleaning:

#### Blowing off the machine with compressed air.

1. Acquire and use eye protection, safety goggles or safety glasses with side guards. Also use respiratory protection, a simple disposable cloth or paper style particle mask is sufficient.
2. Alert all other people in the area to stand clear of the work area a minimum of 30 feet, (7.7 meters) where compressed air is being used to blow off machines.
3. Turn off the machine and disconnect the power line.



**(Warning:** To prevent accidental injury, refer to “The Lock Out / Tag Out Procedure” on page 16.)

4. Remove any loose items from the surfaces of the machine, i.e. Ballpoint pens, pencils, tape dispensers, paper clips rubber bands etc.
5. Open all service doors located on the front side of the machine and remove any loose items that might have been left inside, i.e.; spare parts, tools, personal effects such as purses car keys etc. **(Note:** After a complete visual inspection has been completed and loose items removed, leave the service doors open.)
6. Remove the keyboard and monitor from the stand or cover them with plastic to prevent air borne particles from getting into them. **(Note:** if the inkjet base cabinet is being used to house a computer, remove the computer from the cabinet.)
7. Remove all ink cartridges from the carriage. **(Note:** If a continuous feed ink system is in use, cover the spray orifices with plastic to prevent air borne particles from getting into them.)
8. Hold the air nozzle firmly at arm’s length and blow off the machine beginning with the top surfaces then work your way down.



**(Warning:** Be sure to keep the direction of compressed air blowing away from you.)

**(Note:** High volume businesses running three (3) shifts five (5) days a week should plan this function once a week. Businesses producing light to moderate volume should plan this function once a month.)

### Cleaning Vacuum Transport Belts:

# PITNEY BOWES

1. Acquire and use eye protection, safety goggles or safety glasses with side guards.
2. Turn off the machine and disconnect the power line
3. Clean the following:
  - ✓ Transport Belts of the FIT 36 Base
  - ✓ Transport Belt Tracks and Vacuum Manifold

Apply a liberal amount of “Simple Green” general-purpose cleaner or (“Isopropyl Alcohol”, 70% by volume see warning below) to a soft cloth and wipe down the belt you wish to clean. Advance the belt being cleaned by hand until the entire belt surface has been cleaned.

**⚠ (Warning: Do not spray or pour Simple Green general-purpose cleaner or Isopropyl Alcohol directly onto the belts, free flowing liquids may seep into some electronic components and cause damage)**

**(Note: “Simple Green” general-purpose cleaner and / or “Isopropyl Alcohol” can be purchased at most local grocery stores and drug stores.)**

**⚠ (Warning: Isopropyl Alcohol is FLAMABLE, do not use near an open flame or any other source or device that gives off heat.)**

## General Maintenance

### Lubrication:

The pillow block bearings on each end of conveyor belt pulleys are provided with a grease fitting. To access:

- A. Detach conveyor end belt guard(s) by removing (3) button head screws, see figure IV-1.

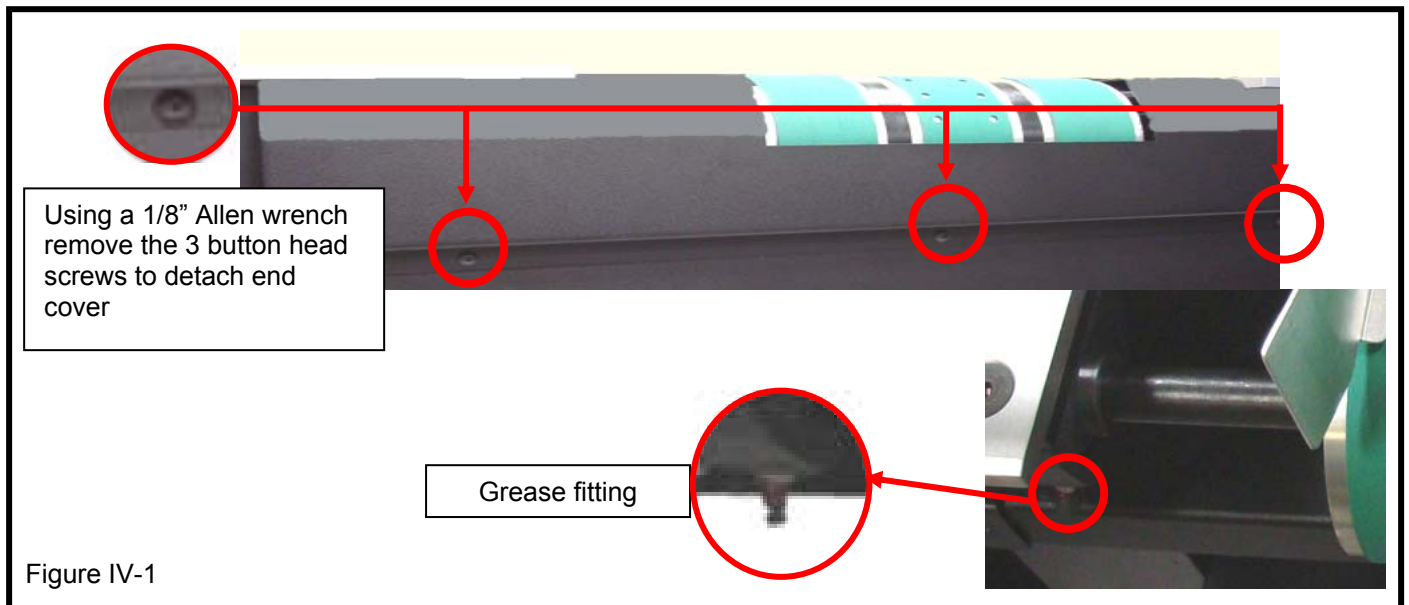

## FIT 36 Base Material Transport Belt Replacement

# PITNEY BOWES

Prepare the work area, clear off the top surface of the vacuum base and be sure power source has been disconnected.

## Top Plate: Disassemble for belt removal

**⚠ (Warning:** Before beginning the process, **turn off and disconnect** the power to the machine.)

1. Disassemble the top plate. This can be accomplished in the following manner:
  - A. Remove knobs from both product side guides, if used and place both aside.
  - B. Using an Allen wrench, remove the button head Allen screws found in the mounting bar brackets at both ends of the material hold down bar, sensor mounting bars and print head supports. Remove the mounting brackets. See figure IV-2.

**⚠ (Caution:** The mounting brackets with sensors on them should be placed gently to the non-operator side of the machine. It is not necessary to remove the sensors if sufficient care is taken.)

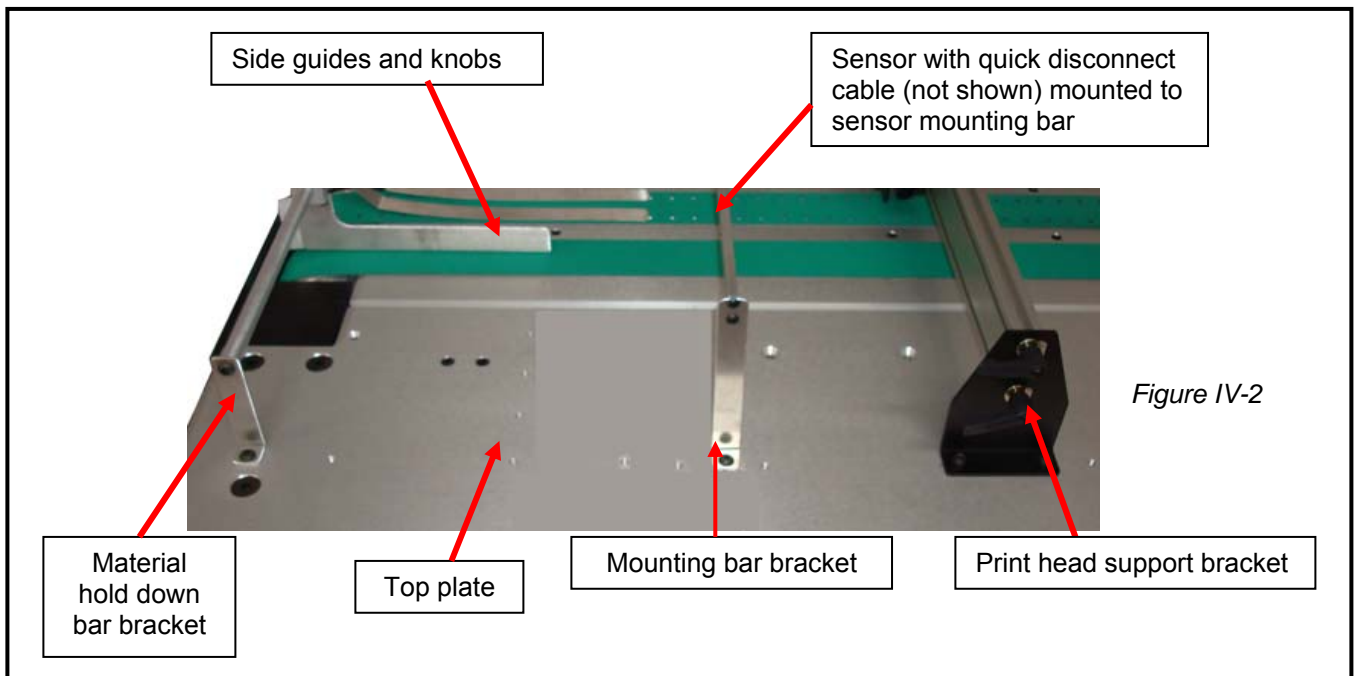

C. Remove front panel with control panel of FIT 36 base. See figure IV-3.

1. Using an Allen wrench, remove (2) button head screws from front panel.

2. Lift front panel up to be free from bottom retaining clips and carefully set aside.

**⚠ Caution:** Control panel electrical cables are still attached to the electrical enclosure- can be detached from enclosure if necessary.

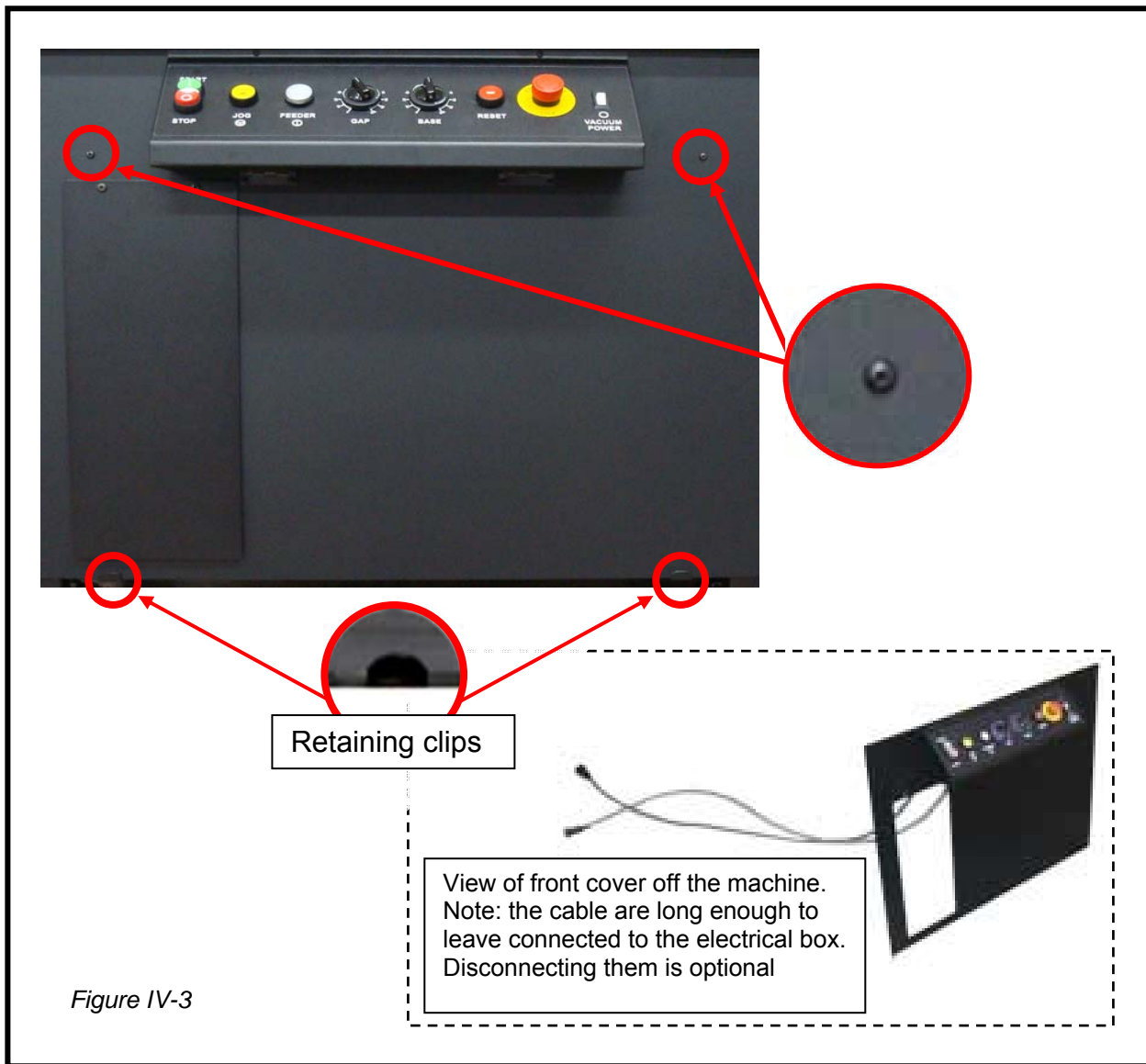

- D. Detach conveyor end belt guard(s) by removing (3) button head screws.  
See figure IV-4.

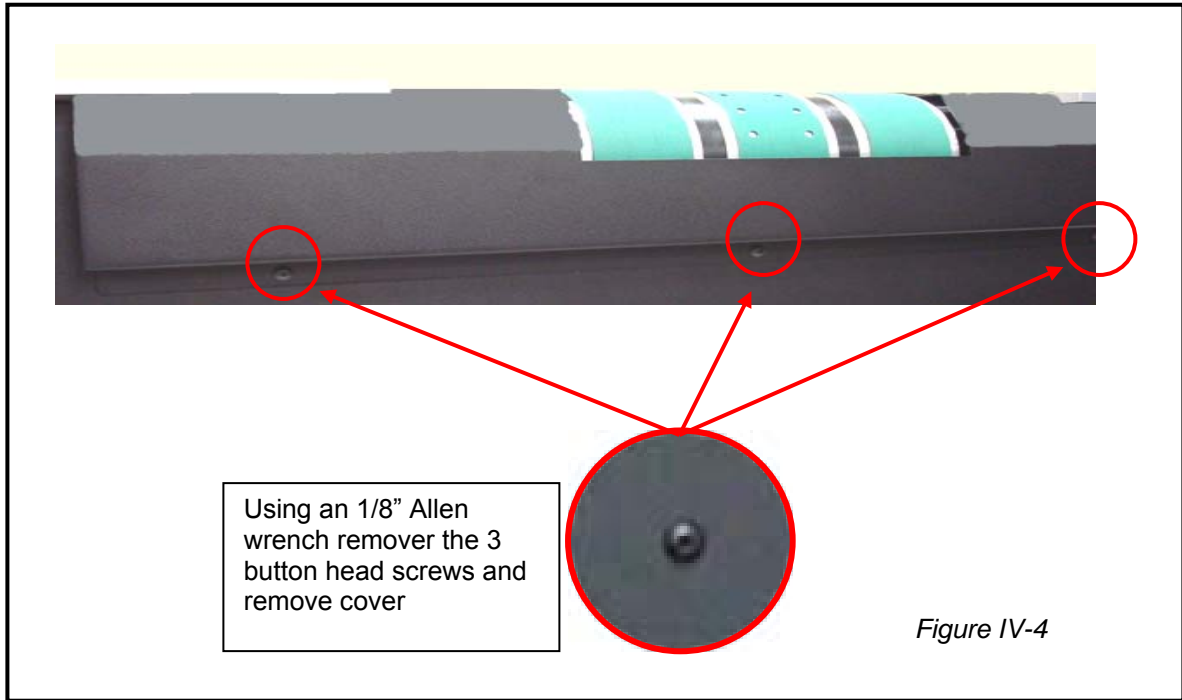

Remove the motor and motor mount plate by performing the following;

- A. Remove the two (2) flat head Allen screws located on the deck, operator's side near the center, see figure IV-5.

**⚠ Caution:** make sure to support the motor while removing the two Flat Head Allen screws in this step, see figure IV-6.

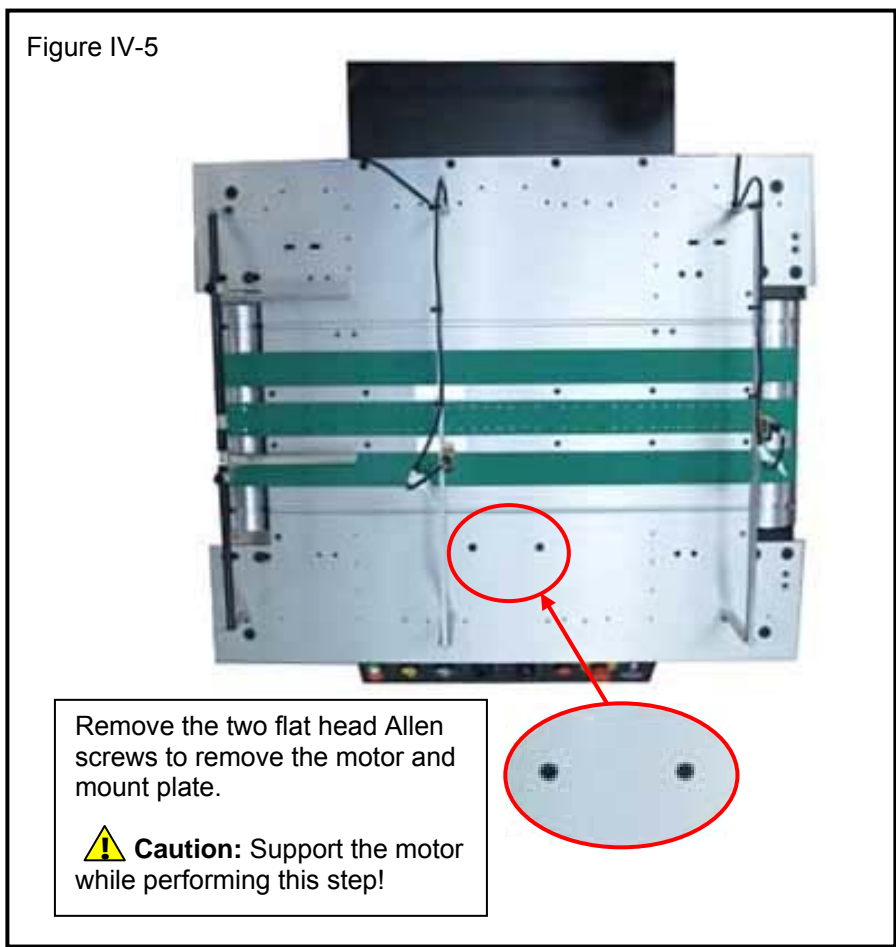

Support the motor and motor mount plate while removing the flat head Allen screws as indicated in step A.

Once the Flat head Allen screws have been removed slide the drive belt off the pulley and set the motor down in the bottom of the machine, see figure IV-6.

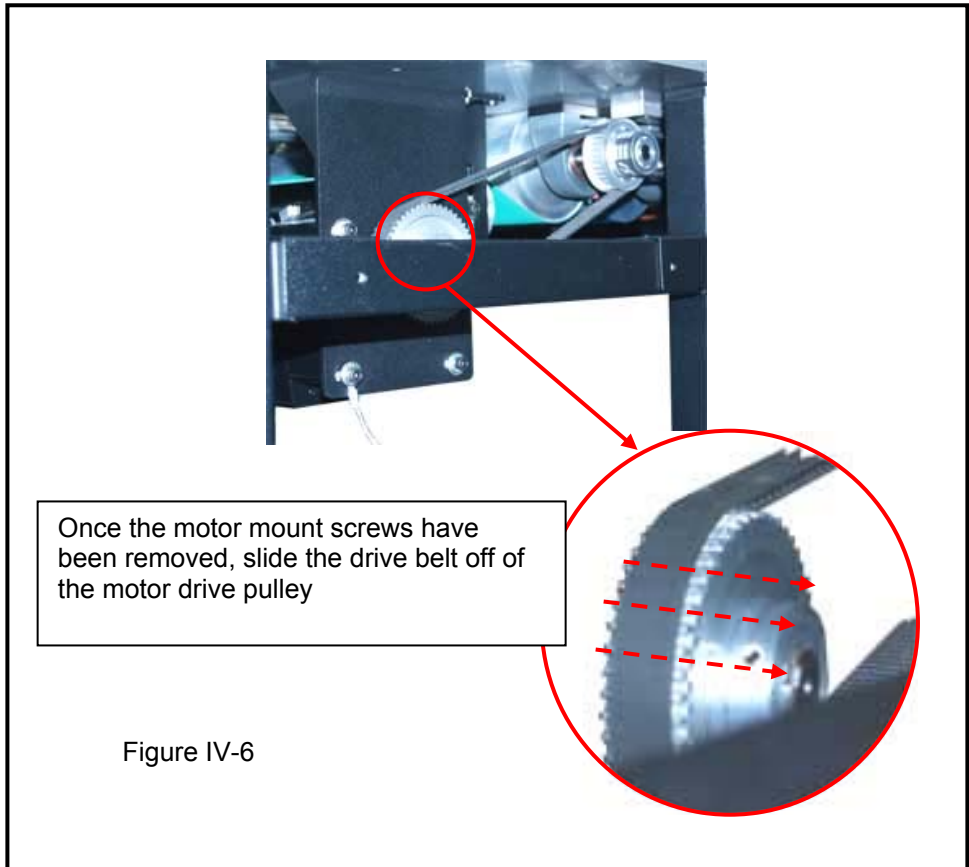

With the Power turned off and the power supply disconnected from the machine, it is not necessary to disconnect the power supply to the motor after lowering the motor to the bottom of the machine base. If you choose to disconnect the power cable to the motor, perform the following:

The connecting plug is located on the cable inside the base cabinet and is easily accessible after the front panel has been removed. Flip the retainer clip up and pull connector apart. See figure IV-7.

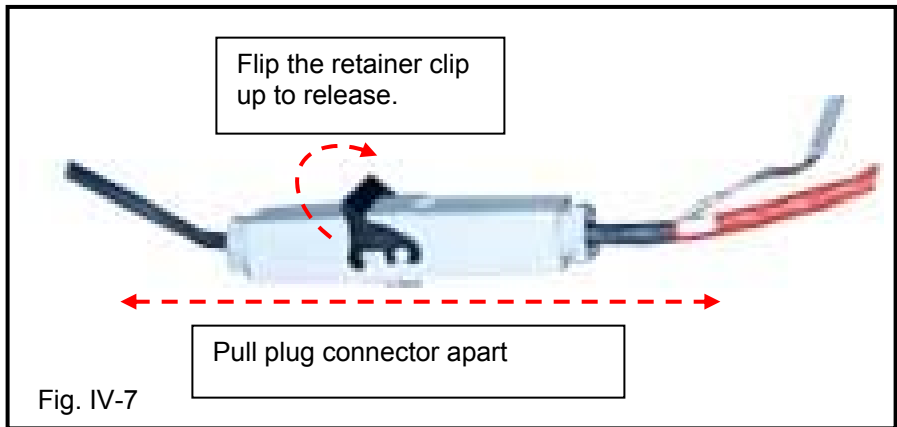
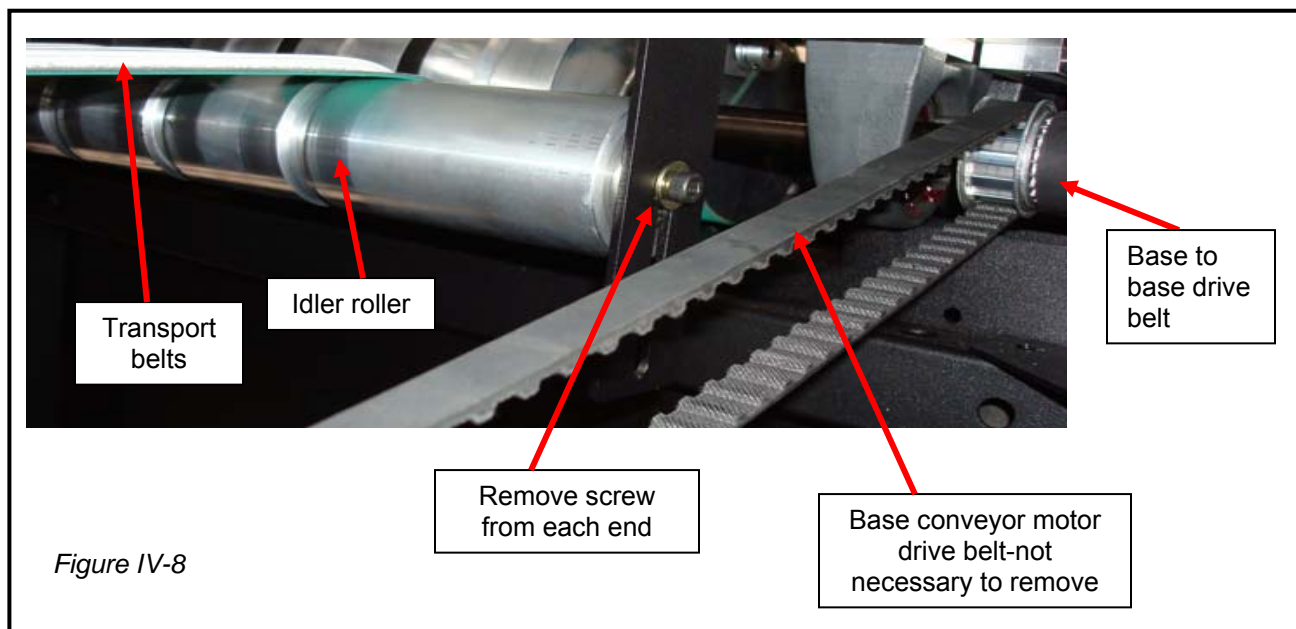

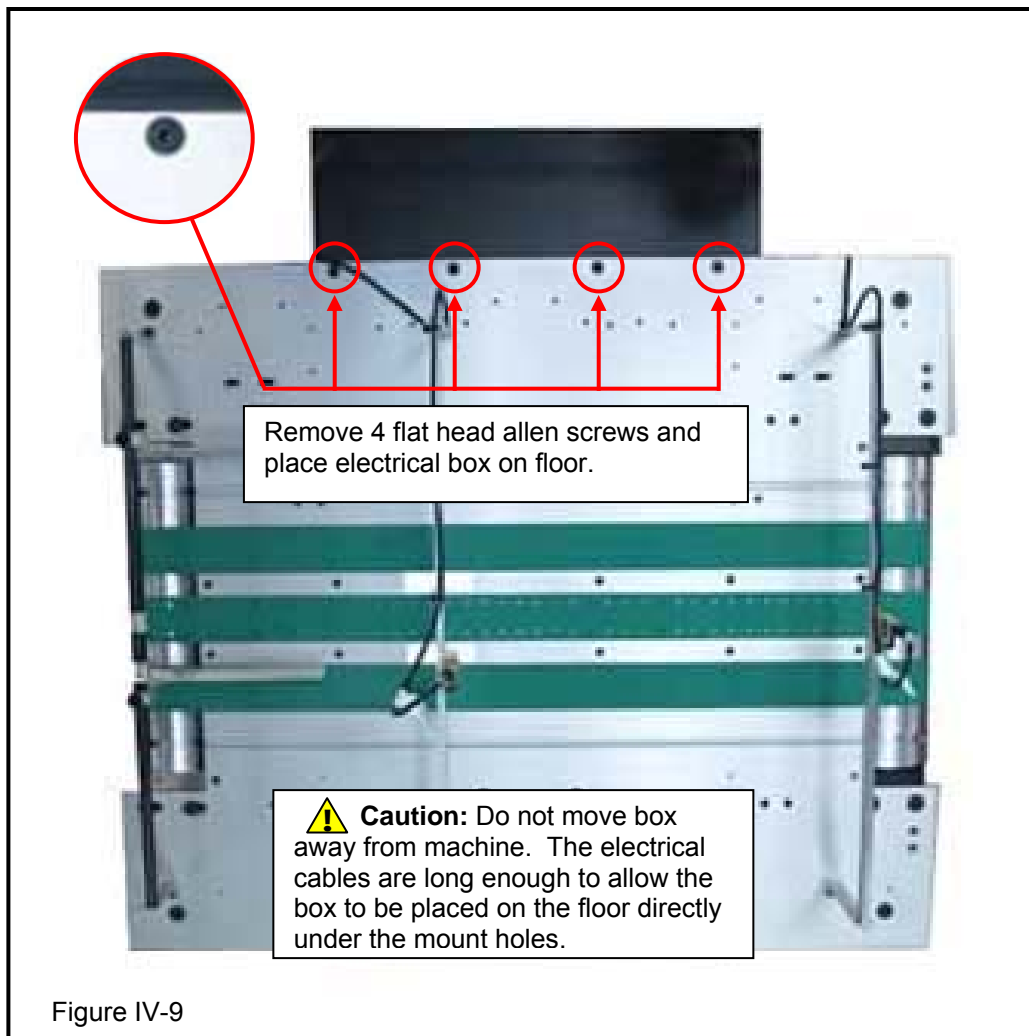

Figure IV-6

- A. Loosen the tension of the material transport belts by performing the following.
- 1) Remove the Allen screw from both ends of the idler roller. (Note: Use caution to prevent the idler roller from dropping.) See figure IV-8.
  - 2) Set the idler shaft assembly aside.



Remove all four (4) flat head Allen screws and lower the main electrical box to the floor, see figure IV-9.



- E. Using an Allen wrench, remove the two (2) flat head Allen screws in front corners (Operator's side) as shown in figure IV-10
- F. Using an Allen wrench, loosen and extract approximately 1/4" the two (2) flat head Allen screws in back corners as shown in figure IV-10.

Loosen 2 flat head screws from the corners on the back side and back them out approximately 1/4"  
**Note:** Do Not Remove These Screws

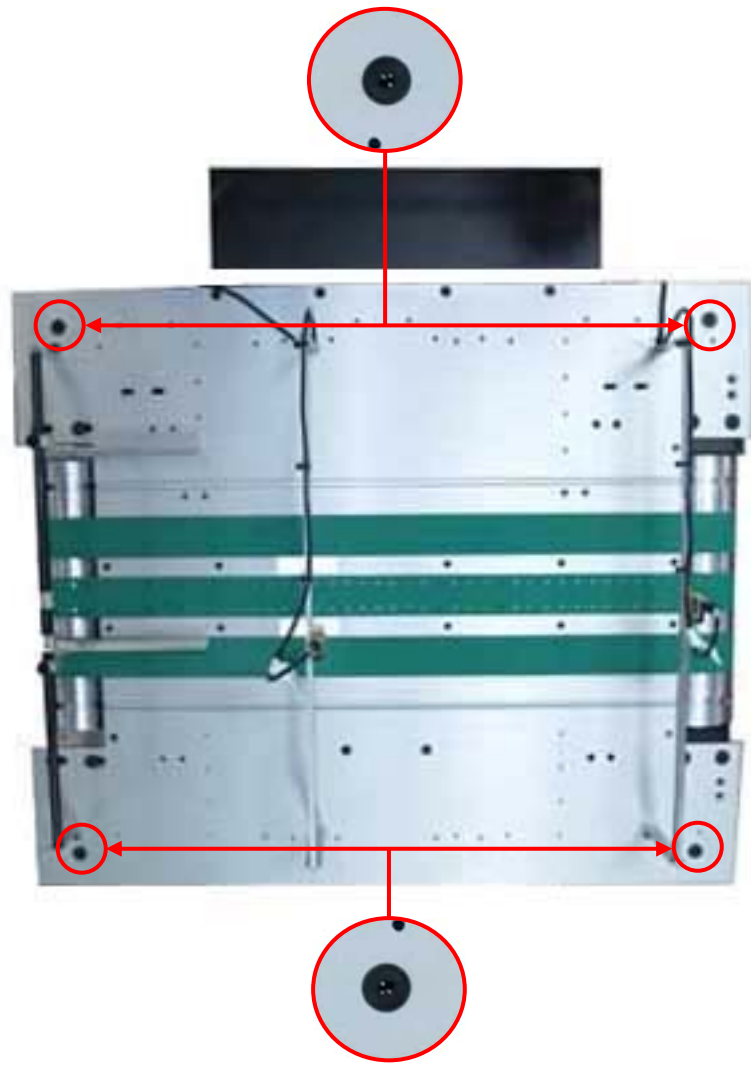

Remove 2 flat head screws from the corners on the Operator's side

Figure IV-10

- H. Lift the front edge of the transport belt top plate assembly up approximately 1” from the vacuum base and slide the old belts, one at a time, towards the front (Operator’s side) to remove them, see figure IV-11.



**(Warning: This assembly weighs 100 pounds, practice safe lifting techniques or ask for assistance with lifting to avoid injury.)**

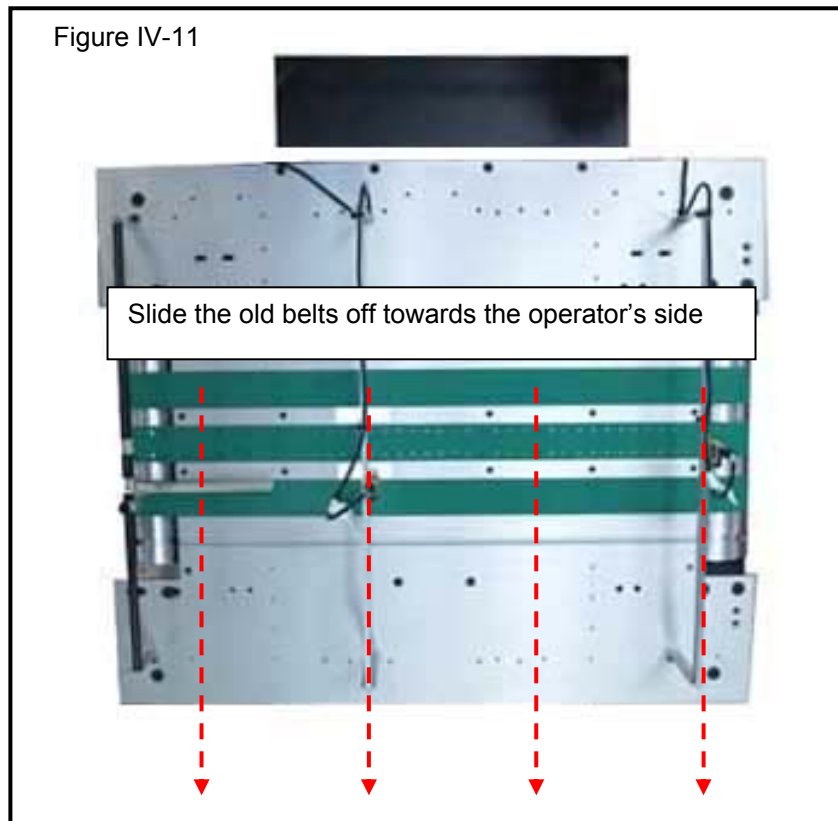

## Transport Belt: Installation

- 3. Install the new Material Transport Belts on the vacuum base by performing the following:
  - A. Slide the new transport belts back onto the transport belt top plate in the reverse order that the old belts came off.
  - B. Return the idler roller assembly to the factory set position, then secure the roller using the Allen screws; tighten the Allen screws with moderate force, see figure IV-8.
  - C. Follow steps 2-A, 1-A thru 1-H in reverse order to install the idler roller, re-tension belts and re-assemble the conveyor.

**FIT 36 Base Rollers and Shafts: Replacement**

**Discharge Roller Shaft Assembly: Removal**

Follow steps 1-E thru 1-H to gain access to the discharge roller.

Follow steps 2-A to release tension on the transport belts

- 4. Remove the discharge roller shaft assembly on the FIT base by performing the following:
  - A. Using an Allen wrench, remove the button head Allen screws, located in slots on top plate, from each of the pillow block bearings. See figure IV-8.

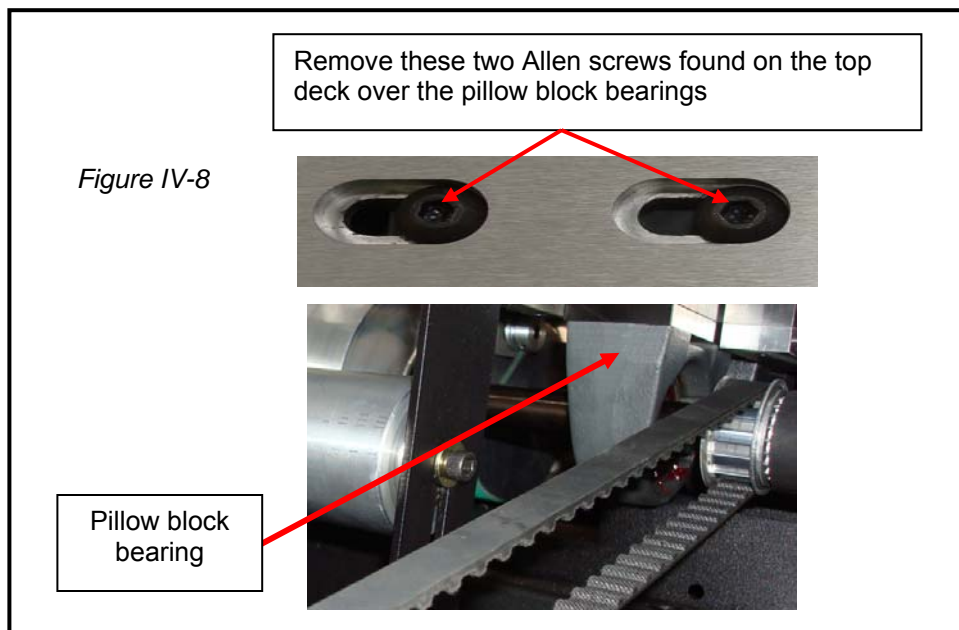

- B. Remove drive belts from sprockets and set them aside for re-use if not worn. Remove discharge roller and replace if necessary.
- C. Reassemble the machine.

# **Section V**

## **Electrical Components**

**FLEXIBLE INKJET TRANSPORT  
36" FIT BASE: FIT-36**



***DIRECT MAIL SOLUTIONS***

12050 49th STREET NORTH - CLEARWATER, FL. 33762-4301  
PHONE: 727.571.3330 - FAX: 727.571.3443 - TOLL FREE: 1.800.INSERTER  
web: [sure-feed.com](http://sure-feed.com)

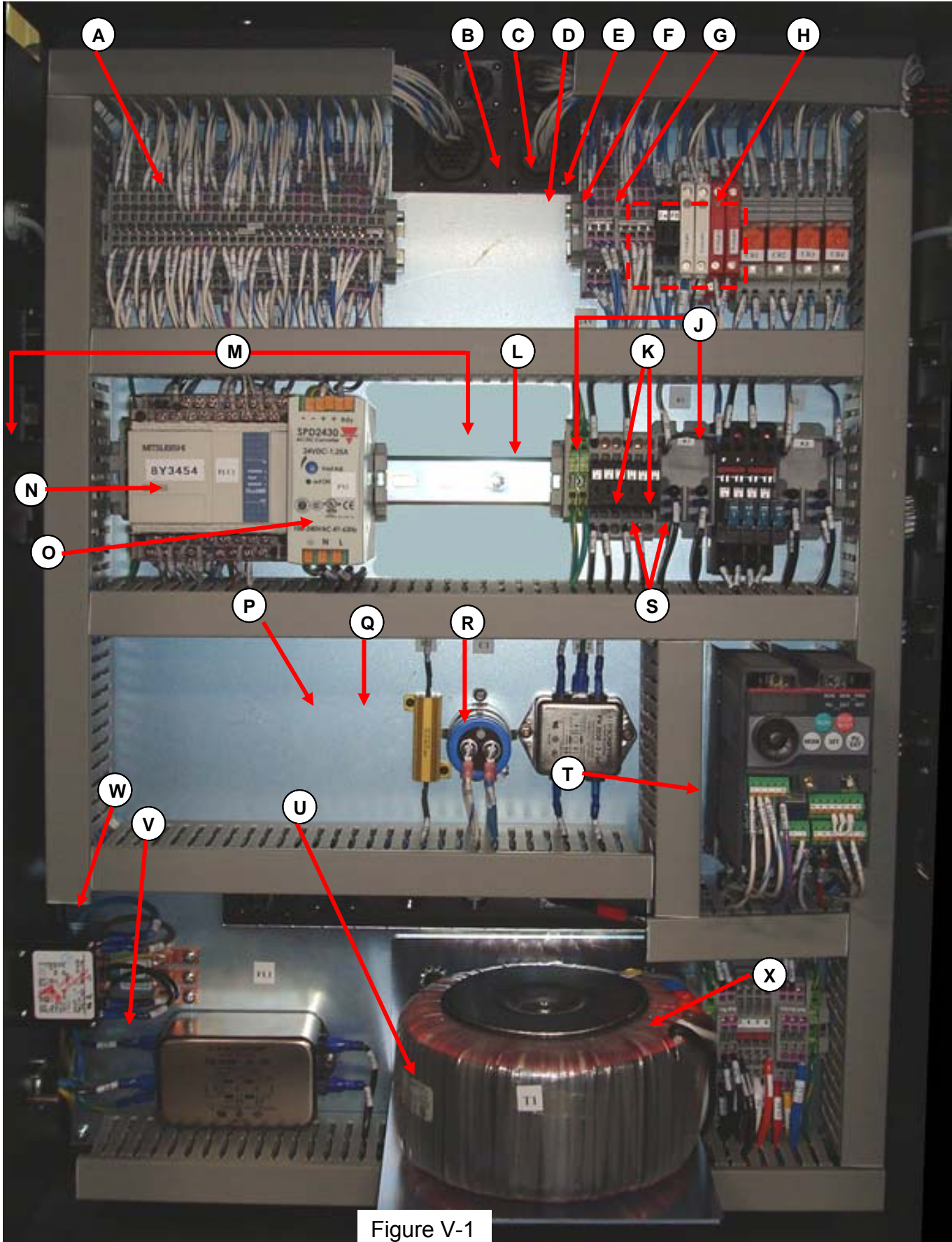

Figure V-1

**Electrical Enclosure Identification Table**

<b>Item</b>	<b>Component</b>	<b>Function</b>
<b>A</b>	Terminal Block	Provides point of contact from components to cables
<b>B</b>	Terminal Block, 24 VDC	Provides 24 VDC
<b>C</b>	Terminal Block, 0 VDC	Provides 0 VDC
<b>D</b>	F4 Fuse	1.25A Power Supply output
<b>E</b>	F5 Fuse	500 mA PLC output
<b>F</b>	Opto Isolator, OFF 1, 2	1: FEEDER PAUSE, 2: PRINT TRIGGER
<b>G</b>	Opto Output Module, 3, 4	3: SORT, 4: DIVERT
<b>H</b>	CR1 Relay	Internal E-Stop Latch
<b>H1</b>	CR2 Relay	VFD
<b>H2</b>	CR3 Relay	External E-Stop Latch
<b>H3</b>	CR4 Relay	RESET
<b>I</b>	RS1, Rocker switch	Speed Following Switch
<b>J</b>	K1, Relay, DPDT, 30A	Transformer output
<b>J1</b>	K2, Relay, DPDT, 30A	Vacuum pump input
<b>K</b>	CB1, 3 Circuit breaker, 3A	Conveyor Motor
<b>L</b>	F1A, 1B FUSE	1.25A Power Supply input
<b>L1</b>	F2A, 2B FUSE	1.25A PLC input
<b>L2</b>	F3A, 3B FUSE	3.15A J12 receptacle
<b>M</b>	Terminal Block, Ground	Provides contact point for AC ground
<b>N</b>	Mitsubishi PLC	Programmable Logic Control, runs machine program
<b>O</b>	Low Voltage Power Supply	Supplies 24 VDC
<b>P</b>	Power resistor	15 $\Omega$ , 50 wt
<b>Q</b>	Capacitor	2200 $\mu$ F capacitor
<b>S</b>	CB2, 4 Circuit breaker, 4A	Vacuum Pump
<b>T</b>	MTR 1	Variable frequency drive-conveyor
<b>U</b>	TRANSFORMER	234/117, 1000 VA
<b>V</b>	RFI FILTER	115/250V, 16A
<b>W</b>	CB0,Circuit breaker, 10A	Circuit breaker 10A, 2 pole
<b>X</b>	TB1	Terminal block for transformer



**Variable Frequency Drive**



Figure V-2

All controls and functions for the Mitsubishi Inverter FR-D700 can be found in Section VIII of this manual. **(Special Note:** Some of the Mitsubishi default operating parameter settings shown in Section VIII have been change for specific use in the 36" FIT Base application. These changes are considered proprietary information of Pitney Bowes and are only intended for use by an authorized specialist. Use of this information by an unauthorized person or persons may void any and all warranties, either real or implied, purchased or offered with the (FIT 36). The manufacturer and all other companies connected with the promotion and sale of the (FIT 36) shall be held harmless for any and all injuries sustained to any person or persons and any damage to the machine or any other product connected there on as a result of failure to comply with this notice.)

Figure V-3

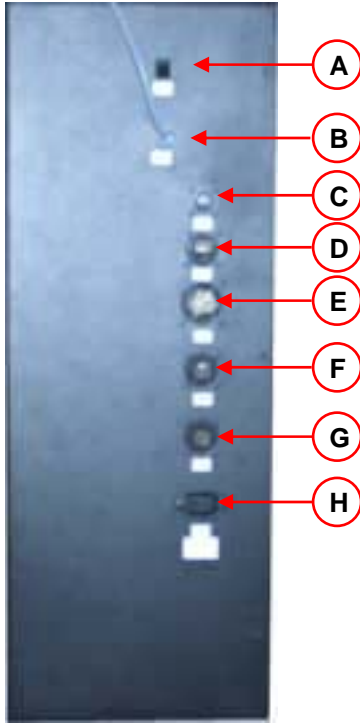

Left Side Main Electrical Box

Item	Connection	Function or Reference Page
A	RS 1	Speed Following Switch
B	P-9	Up-Stream Sensor
C	J-6	To Up-Stream FIT
D	J-4	Reference page
E	J-1	Reference page
F	J-10	Reference page
G	J-11	Reference page
H	120 VAC	120 VAC 3.15 AMP Power Supply

Figure V-4

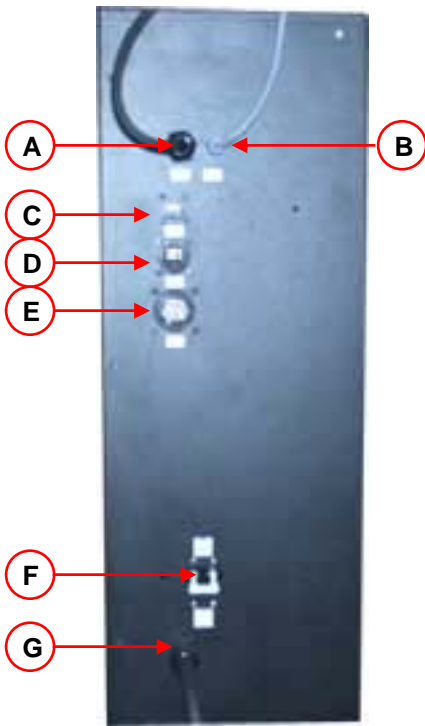

Right Side Main Electrical Box

Item	Connection	Function or Reference Page
A	P-7	Power to Dryer
B	P-8	Down-Stream Sensor
C	J-5	Reference page
D	J-3	Reference page
E	J-2	Reference page
F	None	Circuit Breaker Switch
G	None	Power Cable

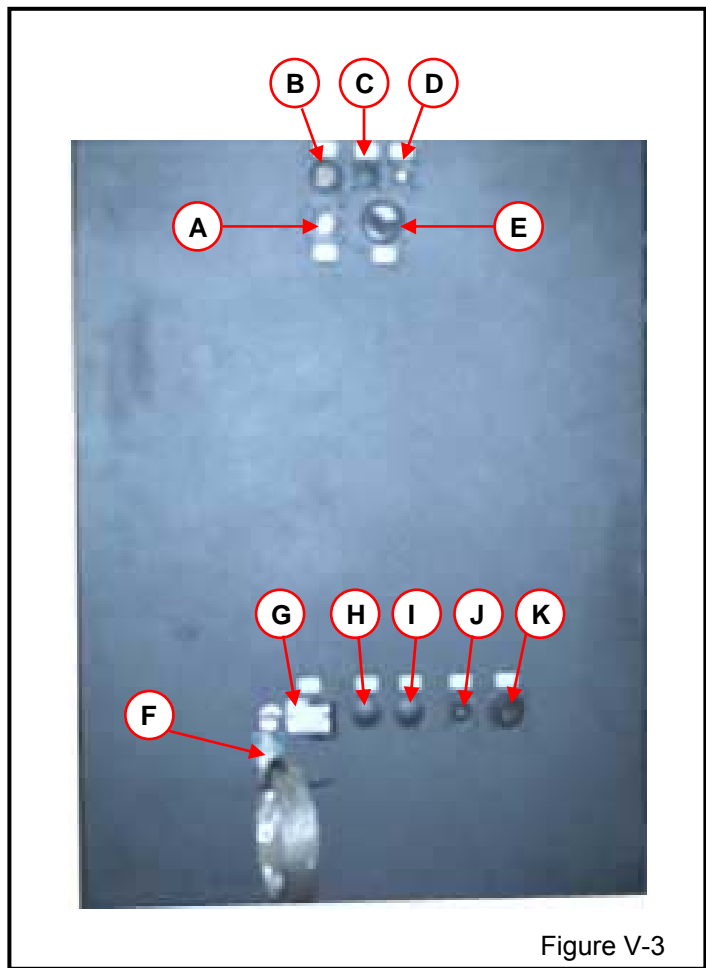

Figure V-3

Item	Connection	Function or Reference Page
A	J-17	Control Panel
B	J-15	Reference page
C	J-14	Reference page
D	J-13	Reference page
E	J-16	Control Panel
F	⊕	Braided Ground Strap
G	J-22	Motor Power Connection
H	J-21	Blank
I	J-20	Blank
J	J-19	Vacuum Pump
K	J-18	Vacuum Pump

## Open Connectors on Fit Enclosure Plug Configuration

### Connection - J1

<b>Pin #</b>	<b>Function</b>
1.	Pass Thru to J2.1
2.	0v
3.	Pass Thru to J2.3. (Used for FlowMaster Stop Integration)
4.	Pass Thru to J2.4
5.	Remote Reset Input (Requires 0v to fire CR4 to Reset Base)
6.	Pass Thru to J2.6
7.	Pass Thru to J2.7
8.	FlowMaster Stop Integration (Momentarily breaks on Stop button push and breaks on E-Stop base has been Reset.)
9.	Pass Thru to J2.9
10.	Pass Thru to J2.10
11.	Pass Thru to J2.11
12.	Remote Run (Supply 0v to this point when you want base to run, must be constant, when voltage drops out base will stop)
13.	Pass Thru to J2.13
14.	Pass Thru to J2.14
15.	Pass Thru to J2.15
16.	Speed Follow Input ( Supply 0-10vdc to allow base to speed follow)
17.	Speed Follow Output (Supplies 0-10vdc, or 0-5vdc for speed following applications for feeder Gap pot adjusts voltage)
18.	Speed Follow Output Com ( 0vdc common for speed following applications)
19.	E-Stop Loop (0vdc E-Stop Loop, Pins J1.19 and J1.20 must be closed to Reset and Run Base / Open to Stop)
20.	E-Stop Loop (0vdc E-Stop Loop, Pins J1.19 and J1.20 must be closed to Reset and Run Base / Open to Stop)
21.	Feeder Dry Contact Start (Common with J1.22 when base is running)
22.	Feeder Dry Contact Start (Common with J1.21 when base is running)
23.	Remote Reset Dry Contact (Common with J1.24, Momentarily closed when Reset Button is pushed)
24.	Remote Reset Dry Contact (Common with J1.23, Momentarily closed when Reset Button is pushed)
25.	Speed Follow Output (Supplies 0-10vdc, or 0-5vdc for speed following applications)
26.	E-Stop Dry Contact (Common with J1.27, Closed when base is in a Run Condition)
27.	E-Stop Dry Contact (Common with J1.26, Closed when base is in a Run Condition)
28.	Remote Reset Com (To Reset Base Dry Contact this pin with J1.29)
29.	Remote Reset (To Reset Base Dry Contact this pin with J1.28)
30.	2 Base Configuration E-Stop Com (Only used if two or more bases are connected together)
31.	2 Base Configuration E-Stop (Only used if two or more bases are connected together)
32.	0vdc Output Signal to tell Second Base it has Stopped
33.	Input X15, (Allows pin 32 from second base to say when it has stopped / Stops base if 0vdc is applied to this pin)
37.	Chassis Ground

## Connection – J2

Pin #	Function
1.	Pass Thru to J2.1
2.	0v
3.	Pass Thru to J2.3. (Used for FlowMaster Stop Integration)
4.	Pass Thru to J2.4
5.	Remote Reset Input (Requires 0v to fire CR4 to Reset Base)
6.	Pass Thru to J2.6
7.	Pass Thru to J2.7
8.	FlowMaster Stop Integration (Momentarily breaks on Stop button push and breaks on E-Stop base has been Reset.)
9.	Pass Thru to J2.9
10.	Pass Thru to J2.10
11.	Pass Thru to J2.11
12.	Remote Run (Supply 0v to this point when you want base to run, must be constant, when voltage drops out base will stop)
13.	Pass Thru to J2.13
14.	Pass Thru to J2.14
15.	Pass Thru to J2.15
16.	Speed Follow Input ( Supply 0-10vdc to allow base to speed follow)
17.	Conveyor Dry Contact Start (Common with J2.18 when base is running)
18.	Conveyor Dry Contact Start (Common with J2.17 when base is running)
19.	E-Stop Loop (0vdc E-Stop Loop, Pins J2.19 and J2.20 must be closed to Reset and Run Base / Open to Stop)
20.	E-Stop Loop (0vdc E-Stop Loop, Pins J2.19 and J2.20 must be closed to Reset and Run Base / Open to Stop)
21.	Sort Signal Dry Contact (Common with J1.22 when Opto 3 is triggered through J10 connector)
22.	Sort Signal Dry Contact (Common with J1.21 when Opto 3 is triggered through J10 connector)
23.	Remote Reset Dry Contact (Common with J1.24, Momentarily closed when Reset Button is pushed)
24.	Remote Reset Dry Contact (Common with J1.23, Momentarily closed when Reset Button is pushed)
25.	Speed Follow Output (Supplies 0-10vdc, or 0-5vdc for speed following applications)
26.	E-Stop Dry Contact (Common with J1.27, Closed when base is in a Run Condition)
27.	E-Stop Dry Contact (Common with J1.26, Closed when base is in a Run Condition)
28.	Remote Reset Com (To Reset Base Dry Contact this pin with J1.29)
29.	Remote Reset (To Reset Base Dry Contact this pin with J1.28)
30.	2 Base Configuration E-Stop Com (Only used if two or more bases are connected together)
31.	2 Base Configuration E-Stop (Only used if two or more bases are connected together)
32.	0vdc Output Signal to tell Second Base it has Stopped
33.	Input X15, (Allows pin 32 from second base to say when it has stopped / Stops base if 0vdc is applied to this pin)
37.	Chassis Ground

## Connection – J3

Pin #	Function
1.	Divert Mocon Signal (Supplies 24vdc when base is running)
2.	Divert Mocon Common (0vdc)
3.	Divert Solenoid 24vdc
4.	Divert Solenoid Signal (Supplies 0vdc to divert piece when Opto. 4 is triggered through J10 connector)
5.	E-Stop Loop (0vdc E-Stop Loop, Break pins 5&6 to Stop Base)
6.	E-Stop Loop (0vdc E-Stop Loop, Break pins 5&6 to Stop Base)

# ***PITNEY BOWES***

## **Connection – J4**

<b>Pin #</b>	<b>Function</b>
1.	Divert Mocon Signal (Supplies 24vdc when base is running)
2.	Divert Mocon Common (0vdc)
3.	Divert Solenoid 24vdc
4.	Divert Solenoid Signal (Supplies 0vdc to divert piece when Opto. 4 is triggered through J10 connector)
5.	E-Stop Loop (0vdc E-Stop Loop, Break pins 5&6 to Stop Base)
6.	E-Stop Loop (0vdc E-Stop Loop, Break pins 5&6 to Stop Base)

## **Connection – J5**

<b>Pin #</b>	<b>Function</b>
1.	Remote Start Input (Supply momentary 0vdc signal to Start base)
2.	Remote Stop Input (Supply momentary 0vdc signal to Stop base)
3.	Remote Jog Input (Supply 0vdc to Jog machine)

## **Connection – J6**

<b>Pin #</b>	<b>Function</b>
1.	Remote Start Input (Supply momentary 0vdc signal to Start base)
2.	Remote Stop Input (Supply momentary 0vdc signal to Stop base)
3.	Remote Jog Input (Supply 0vdc to Jog machine)

## **Connection – J7**

<b>Pin #</b>	<b>Function</b>
1.	Dryer Run Signal (Supplies 24vdc to run dryer when base is running and pieces are making and breaking input sensor)
2.	Dryer Run Common (Supplies 0vdc to run dryer when base is running)

## **Connection – J10**

<b>Pin #</b>	<b>Function</b>
1.	24vdc
2.	0vdc
3.	Divert Signal Input ( Supply 0vdc to this point to trigger Divert)
4.	Sort Signal Input (Supply 0vdc to this point to trigger Sort Conveyor)
5.	5-24vdc Input Common (Supply 5-24vdc at all times to power Opto's controlling Sort, Divert, and Feeder Pause)
6.	Feeder Pause Input (Supply 0vdc to this point to Pause Feeder)
7.	5-24vdc Pull Up (Supply 5-24vdc for run up signal for Print Trigger)
8.	0-24vdc Signal Output (Supplies 0-24vdc depending on state of Opto for Print Trigger Output)
9.	0vdc Pull Down (Supply 0vdc for run down signal for Print Trigger)

## **Connection – J11**

<b>Pin #</b>	<b>Function</b>
1.	Pass Thru to J15.1
2.	Pass Thru to J15.2
3.	Pass Thru to J15.3
4.	Pass Thru to J15.4
5.	Pass Thru to J15.5
6.	Pass Thru to J15.6
7.	Pass Thru to J15.7
8.	Pass Thru to J15.8
9.	Pass Thru to J15.9

## **Connection – J13**

<b>Pin #</b>	<b>Function</b>
--------------	-----------------

- |    |  |
|----|--|
| 1. | Divert Mocon Signal (Supplies 24vdc when base is running)  |
| 2. | Divert Mocon Common (0vdc)   |
| 3. | Divert Solenoid 24vdc  |
| 4. | Divert Solenoid Signal (Supplies 0vdc to divert piece when Opto. 4 is triggered through J10 connector) |

## **Connection – J15**

<b>Pin #</b>	<b>Function</b>
--------------	-----------------

- |    |                    |
|----|--------------------|
| 1. | Pass Thru to J11.1 |
| 2. | Pass Thru to J11.2 |
| 3. | Pass Thru to J11.3 |
| 4. | Pass Thru to J11.4 |
| 5. | Pass Thru to J11.5 |
| 6. | Pass Thru to J11.6 |
| 7. | Pass Thru to J11.7 |
| 8. | Pass Thru to J11.8 |
| 9. | Pass Thru to J11.9 |

Figure V-4

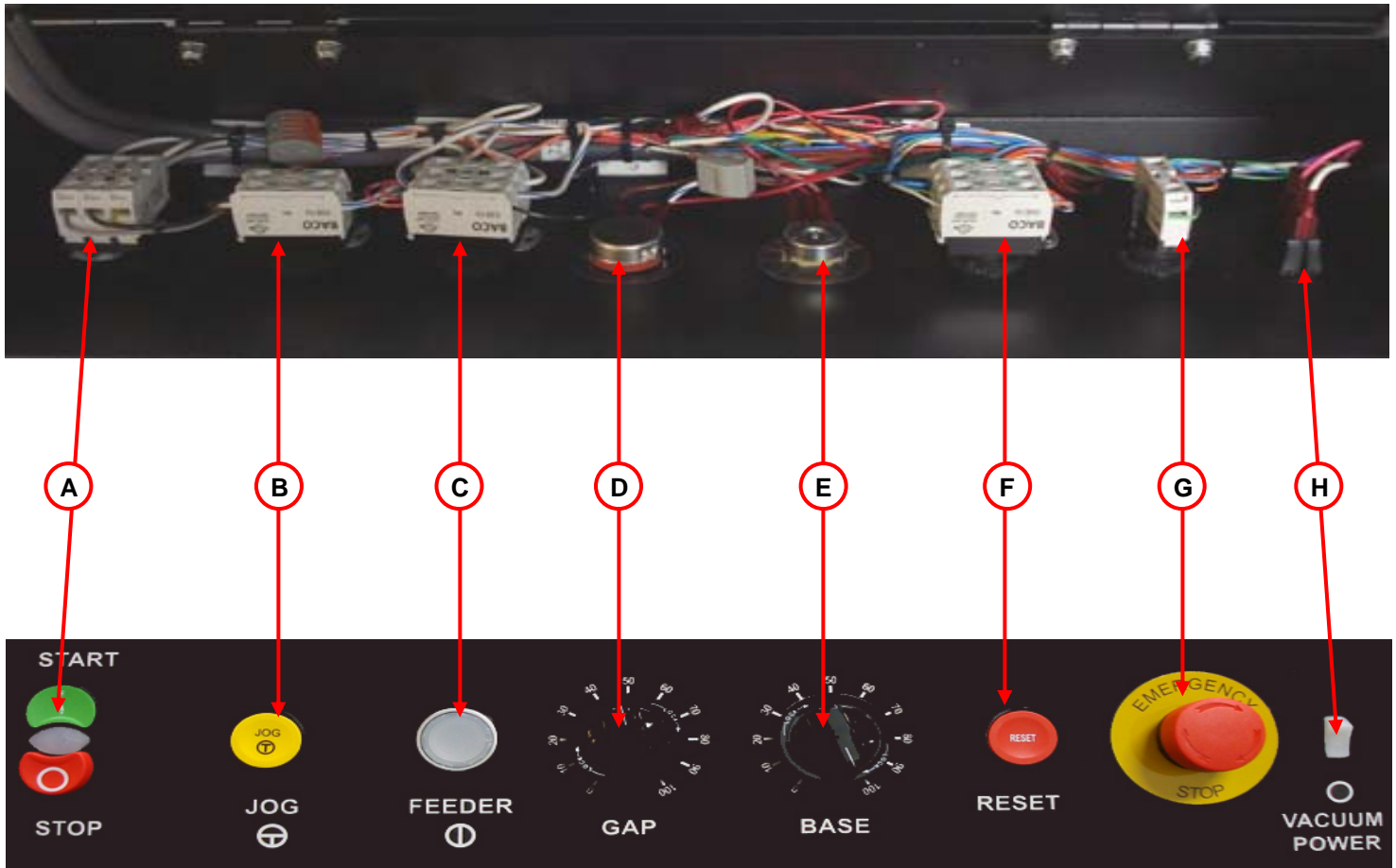

**CONTROL CONSOLE COMPONENT LIST**

Item	Component	Device Description	Function
A	Pushbutton, illuminated	3 Contactor Switch, NO / NC / NO	Start-Stop of vacuum base conveyor
B	Jog pushbutton, momentary	1 Contactor Switch, NO	Provides for jogging of conveyor
C	Feeder pushbutton, illuminated	2 Contactor Switch, NO / NC	Start-stop of in-feed feeder
D	Gap Speed Dial	Potentiometer	Feeder Speed Control
E	Base Speed Dial	Potentiometer	Base Speed Control
F	Reset pushbutton, red	2 Contactor Switch, NO / NO	Resets system after fault is corrected
G	E-STOP pushbutton, non-illuminated	2 Contactor Switch, NC / NC	Provides safety shutdown
H	Vacuum pump switch	Rocker Style Switch	Start-stop of vacuum pump



# **Section VI**

## **Wiring Diagrams For FLEXIBLE INKJET TRANSPORT**

### **36" FIT BASE: FIT-36 SERVICE MANUAL**



***DIRECT MAIL SOLUTIONS***

12050 49th STREET NORTH - CLEARWATER, FL. 33762-4301  
PHONE: 727.571.3330 - FAX: 727.571.3443 - TOLL FREE: 1.800.INSERTER  
web: [sure-feed.com](http://sure-feed.com)

**Main Electrical Enclosure 16021-105 rD2**

ITEM	PART NUMBER	DESCRIPTION	QTY
1	16013-288	FIT Main Control Enclosure	1
2	16013-290	FIT Main Control Enclosure, cover	1
3	12013-050	Back Panel, Fit Control Enclosure	1
4	16009-180	Transformer Bracket, FIT Control Enclosure	1
5	98016-222	Terminal ring, 1/4, 14-16 AWG (blue)	1
6	98012-008	Duct. Wire with cover 1" X3" high density	10.2"
7	98001-022	Din rail	3.5'
8	98008-026	Transformer234 / 117 V	1
9	98020-104	Line Filter, 16 A	1
10	98003-072	Panel mounting base, w/single locking latch	1
11	98003-070	Female insert, 3-pos., screw connection	1
12	98001-134	Terminal, dbl layer shorted (4 way)	5
13	98001-131	Terminal, 3 wire, fuse disconnect	8
14	98001-138	Spring Ground Terminal	7
15	98001-123	End Stop Terminal	9
16	98001-132	End Cover, 3 wire, fuse disconnect	2
17	98001-136	End Cover, dbl layer shorted (4 way)	2
18	98001-140	End cover ground terminal	4
19	98019-068	Straight pressure tongue, ground lug	3
20	98002-060	Relay, DPDT, 30A, 24 VDC	2
21	98001-114	Terminal block, circuit breaker	4
22	98013-133	Inverter, 1HP, motor controller	1
23	98013-054	Mitsubishi, PLC FX1N-24MR	1
24	98011-018	Power Supply 24 V 1.25 A DC	1
25	98020-070	Output Module, 4-28VDC coil, 3A@60 VDC	2
26	98013-015	Opto Isolator, (OFF)	2
27	98002-058	Relay, DPDT, 24 VDC w/ din rail base	4
28	98001-139	Terminal, dbl layer (6 way)	23
29	98001-135	Terminal, dbl layer shorted (6 way)	14
30	98001-137	End cover, dbl layer (6 way)	3
31	98001-130	Bridge 2 position terminal	4
32	98001-145	Jumper, 3 pole, fuse terminal	2
33	98001-129	Bridge 3 position terminal	1
34	98001-126	Fuse holder, pop off	8
35	98004-089	Circuit breaker, 4A	2
36	16021-142	<b>ASSY, GROUND STRAP, 40"</b>	1
37	98016-219	Quick disconnect, 0.250 female, 14-16 AWG (blue)	16
38	98016-221	Terminal Ring, #8, 14-16 AWG (blue)	2
39	98010-206	Wire, #18 AWG, 600 V violet	4'
40	98010-197	Wire, #18 AWG, 600 V green w/ yellow	7'
41	98010-158	Wire, #14 AWG, 600 V black	9

**Main Electrical Enclosure 16021-105 rD2**

ITEM	PART NUMBER	DESCRIPTION	QTY
42	98010-121	Wire, #18 AWG, 600 V blue	7'
43	98010-132	Wire, #16 AWG, 600 V black	7'
44	98010-208	Wire, #18 AWG, 600 V white w/ blue	16'
45	98010-104	Wire, #22 AWG, 600 V blue	20'
46	98010-209	Wire, #22 AWG, 600 V white w/ blue	20'
47	98010-108	Wire, #22 AWG, 600 V white w/ black	30'
48	98010-033	Wire, #14 AWG, 600 V green w/ yellow	5.5'
49	98010-226	Cord set, 4 socket EURO, with leads, 5m	2
50	98015-027	Cord grip, 1/2 gray	2
51	98010-254	18-3C flex cord euro cc w/g type slow	15'
52	98020-045	Resistor, 1K	1
53	98010-253	14-3 flex cord euro cc w/g type slow	15'
54	98016-103	Receptacle, sq. ft. 37 pos	3
55	98016-091	Receptacle, sq. flange, 17-14 pos	1
56	98016-011	Receptacle sq. flange, 11-4 STD	5
57	98015-003	Metal locknut, 1/2"	2
58	98015-001	Strain releife, 1/2"	2
59	98016-093	Receptacle, sq. flange, 17-9 pos	5
60	16015-038	Label 120 VAC 3.15 A	1
61	98016-217	Quick disconnect, 0.187 female, 18-22 AWG (red)	5
62	98016-216	Quick disconnect, 0.250 female, 18-22 AWG (red)	4
63	98001-143	Bridge 4 position, terminal	1
64	98004-098	Circuit Breaker, 15AMP, 2 pole	1
65	98003-010	Plug, 3 pin, 2 pole, 15A	1
66	98004-019	Fuse, 500mA, 250 V 5X20MM GMC time delay	1
67	98004-070	Fuse , 5 X 20, time delay 1.25A	5
68	18021-165	<b>ASSY, GROUND STRAP, F.T.</b>	1
69	98004-096	Fuse, 5X20, 3.15 A-slow-blow	2
70	98015-023	Finishing Plug, 7/8" hole	3
71	98016-028	Contact, Socket, 16-12 AWG	2
72	98016-027	Contact, Socket, 24-20 AWG	129
73	98020-038	Resistor, Power, 15 OHM, 50w	1
74	98016-060	Contact, socket, 18-14-AWG	4
75	98016-002	Receptacle, sq. flange, series 3, 17-3	1
76	98001-073	Bridge, 2 position	2
77	98001-107	Terminal block, dual, spring cage disconnect	4
78	98001-108	Side cover, dual terminal block	1
79	98003-018	Receptacle, Twist Lock	1
80	98016-223	Terminal ring, #10, 14-16 AWG (blue)	1

**Main Electrical Enclosure 16021-105 rD2**

<b>ITEM</b>	<b>PART NUMBER</b>	<b>DESCRIPTION</b>	<b>QTY</b>
81	98019-045	Heat shrink, 1/4", pvc black	6"
82	98019-067	Heat shrink, 5/16", pvc black	6"
83	98020-036	Capacitor, 2200uF	1
84	98020-037	Cap, Mounting hardware	1
85	98016-224	Terminal ring, #10, 18-22 AWG	3
86	98000-121	Switch, DPDT, On-On	1
87	16011-373	IEC-320, Cover Plate	1
88	16008-218	Bar, Board blank, FIT Base	1
89	98003-049	Receptacle, AC, IEC-320	OPT
90	98020-107	Filter - RFI, 115 / 250, 3A	1
91	99039-069	High Voltage decals	1
92	16008-214	BAR, ENCLOSURE MTG.	1
93	98003-008	Plug, 230 V, 10 A, NEMA 6-15P	OPT
94	98003-060	Plug, 230 V, 10 A, EUROPE	OPT
95	98003-061	Plug, 230, 13 A UK	OPT
96	98003-062	Plug, 230 V, 10 A, CHINA	OPT
97	98004-090	Circuit breaker, 6 A	2
98	98013-151	DYANAMIC BRAKE RESISTOR	OPT

This record is the property of Pitney Bowes and is loaned to you for your use only. It is not to be copied, reproduced, or distributed.

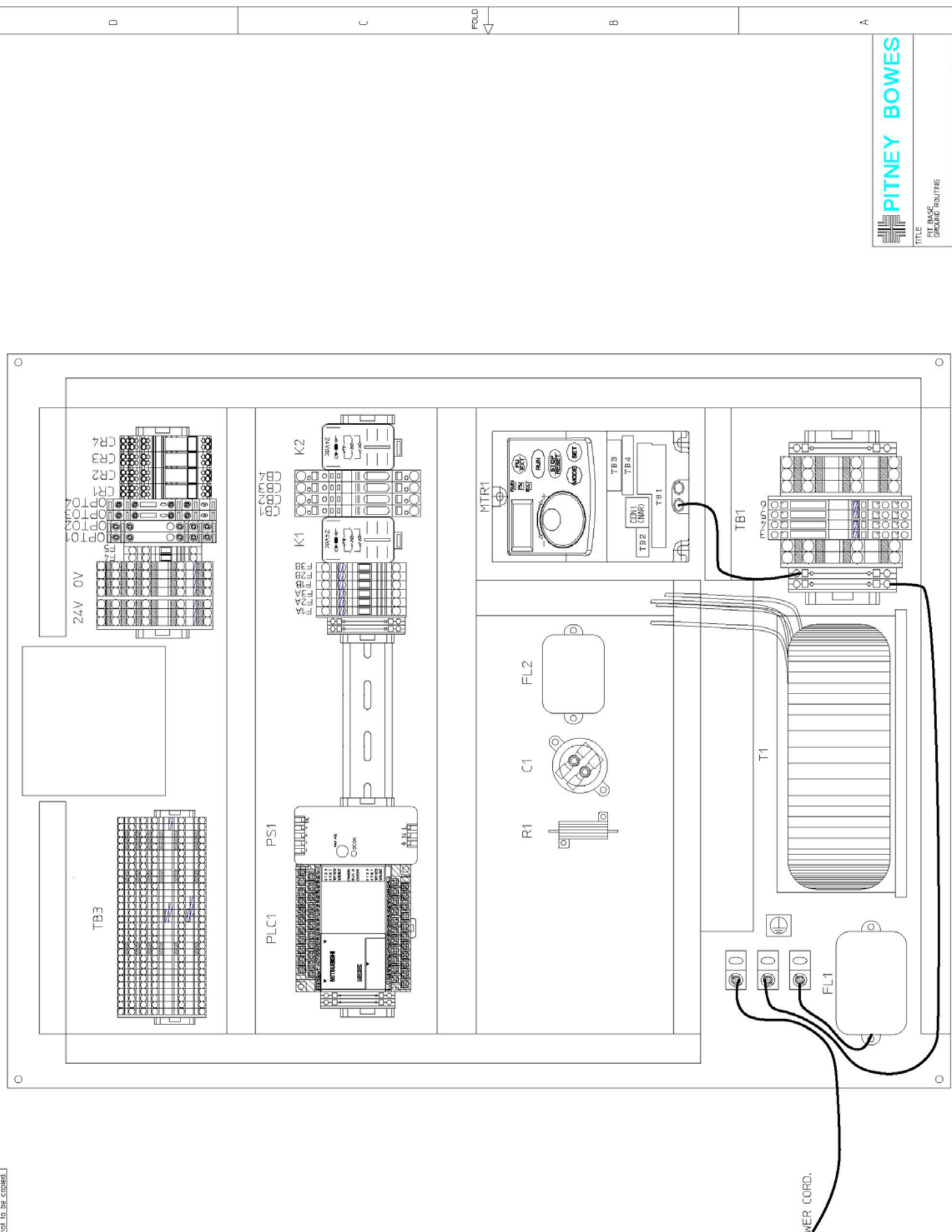

FROM POWER CORD.



TITLE	FIT BASE GROUND ROUTING
DRAWING NUMBER	16021-105
REV	D2
SIZE	C SCALE DO NOT SCALE DRAWING   SHEET 2 OF 11

This record is the property of Pitney Bowes Inc. and is loaned to you for your use only. It and its contents are not to be copied, reproduced, or distributed without the written consent of Pitney Bowes Inc.

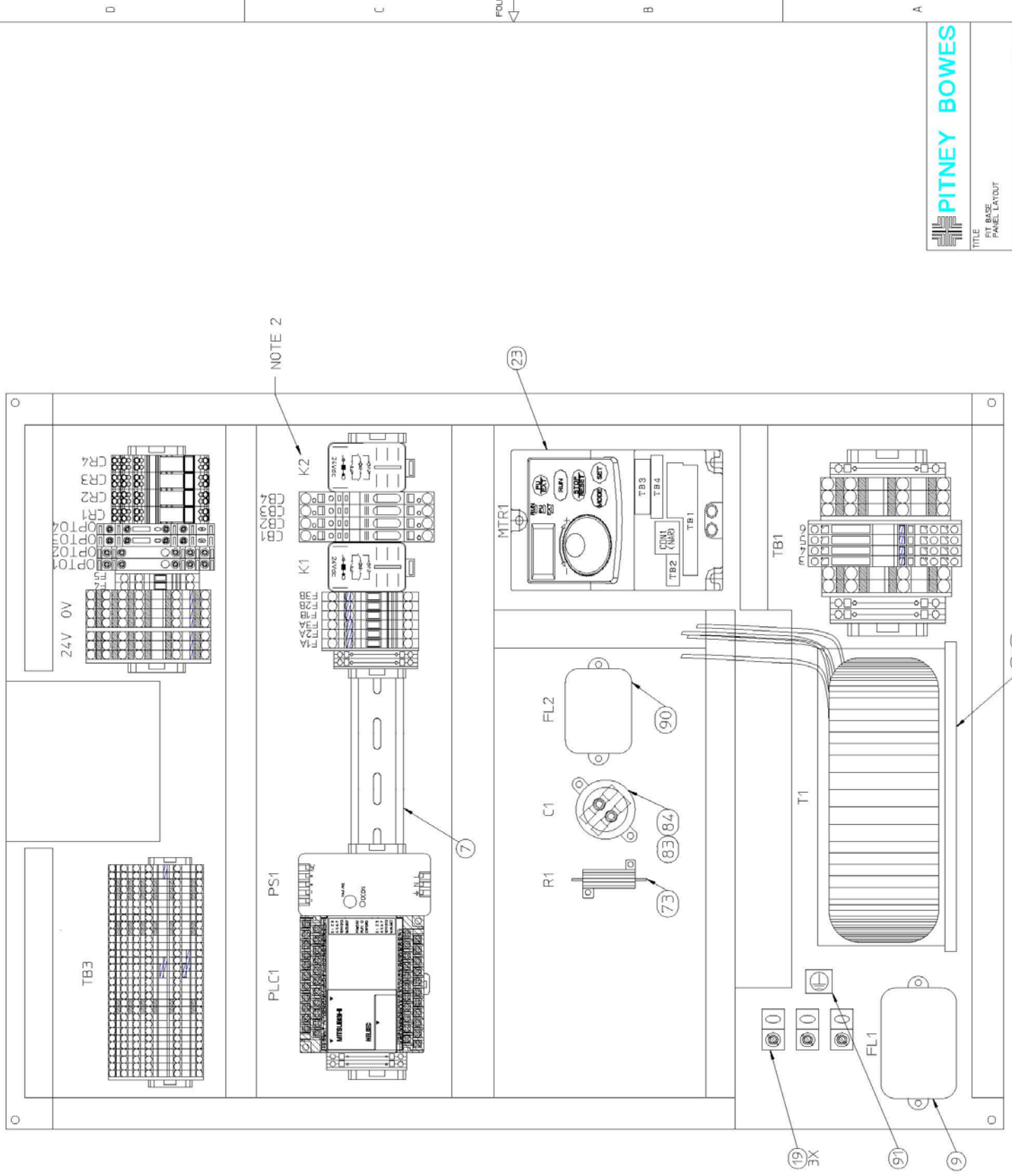

**PITNEY BOWES**

TITLE  
FIT BASE  
PANEL LAYOUT

DRAWING NUMBER  
16021-105

REV D2  
SIZE C SCALE 00 NOT SCALE DRAWING | SHEET 3 OF 11

1

2

3

4

5

This record is the property of Pitney Bowes and should not be copied, reproduced, or distributed without the express written consent of Pitney Bowes.

TB3

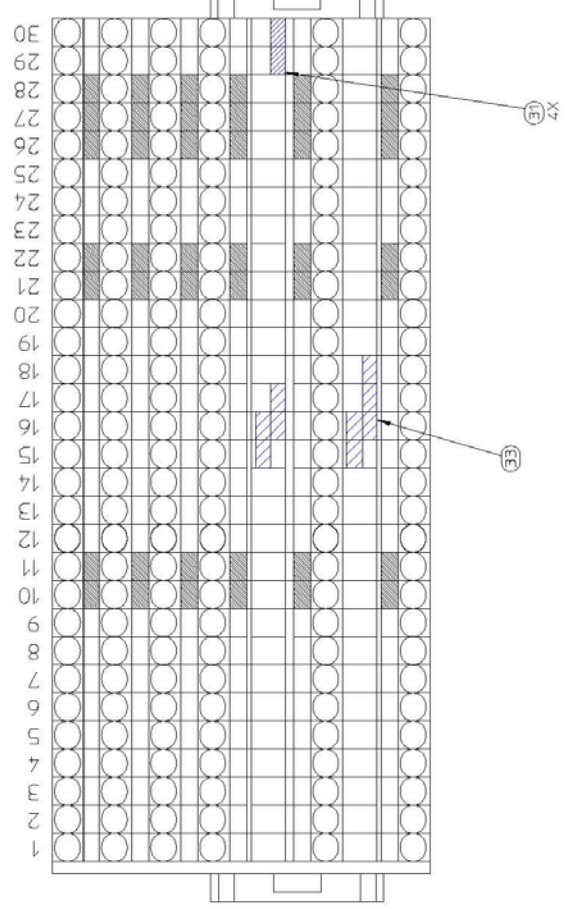

NOTE:  
IF 2 BASES ARE HOOKED TOGETHER,  
PLACE TWO 2 POSITION JUMPER (98001-130)  
IN TB3.2B TO TB3.3B AND TB3.23B TO TB3.24B.

QTY	DESCRIPTION
1	End stop terminal
2	Terminal, dbl layer (6 way)
3	Terminal, dbl layer shorted (6 way)
3	Terminal, dbl layer (6 way)
2	Terminal, dbl layer shorted (6 way)
9	Terminal, dbl layer (6 way)
2	Terminal, dbl layer shorted (6 way)
9	Terminal, dbl layer (6 way)
1	End cover, dbl layer terminal (6 way)
1	End stop terminal

**PITNEY BOWES**

TITLE  
FIT BASE  
LOW VOLTAGE TB LAYOUT

DRAWING NUMBER  
46021-105

REV  
D2

SIZE C | SCALE DD | NOT SCALE DRAWING | SHEET 4 OF 11

TERMINAL BLOCK LAYOUT (LEFT TO RIGHT)

5

4

FOLD

2

1

This record is the property of Pitney Bowes and is loaned to you for your use only. It and its contents are not to be copied, distributed, or otherwise used without the express written consent of Pitney Bowes.

D C B A

FOLD

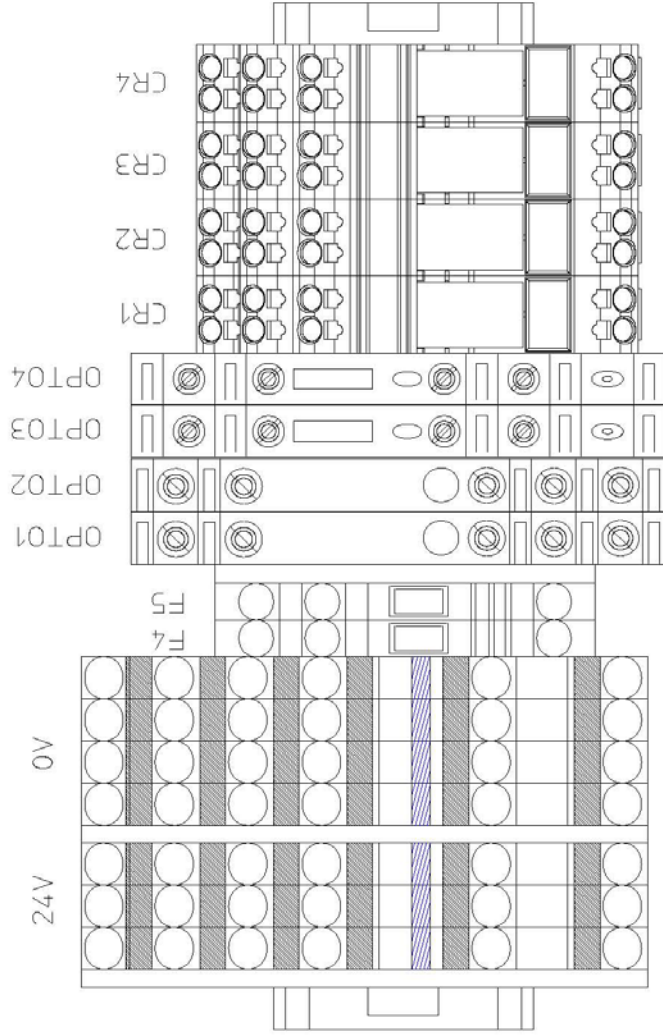

TITLE  
FIT BASE  
24V TB LAYOUT

DRAWING NUMBER  
46021-105

REV  
D2

SIZE C SCALE DO NOT SCALE DRAWING | SHEET 5 OF 91

U/FAC	QTY	DESCRIPTION
249-116	1	End stop terminal
788-312	4	Relay, DPDT, 24V AC/DC, Dinnal base
3-00C-R0-060	2	Output Module 3A
0-1DC-R0-028	2	Opto Isolator Off
291-670	1	Terminal cover, 3 wire fuse disconnect
291-324	2	Terminal, 3 wire fuse disconnect
870-538	4	Terminal, dbl layer shorted (6 way)
870-573	1	End cover, dbl layer terminal (6 way)
870-538	3	Terminal, dbl layer shorted (6 way)
870-573	1	End cover, dbl layer terminal (6 way)
249-116	1	End stop terminal

U/FAC L R E R S P N QTY DESCRIPTION

TERMINAL BLOCK LAYOUT (Left to Right)



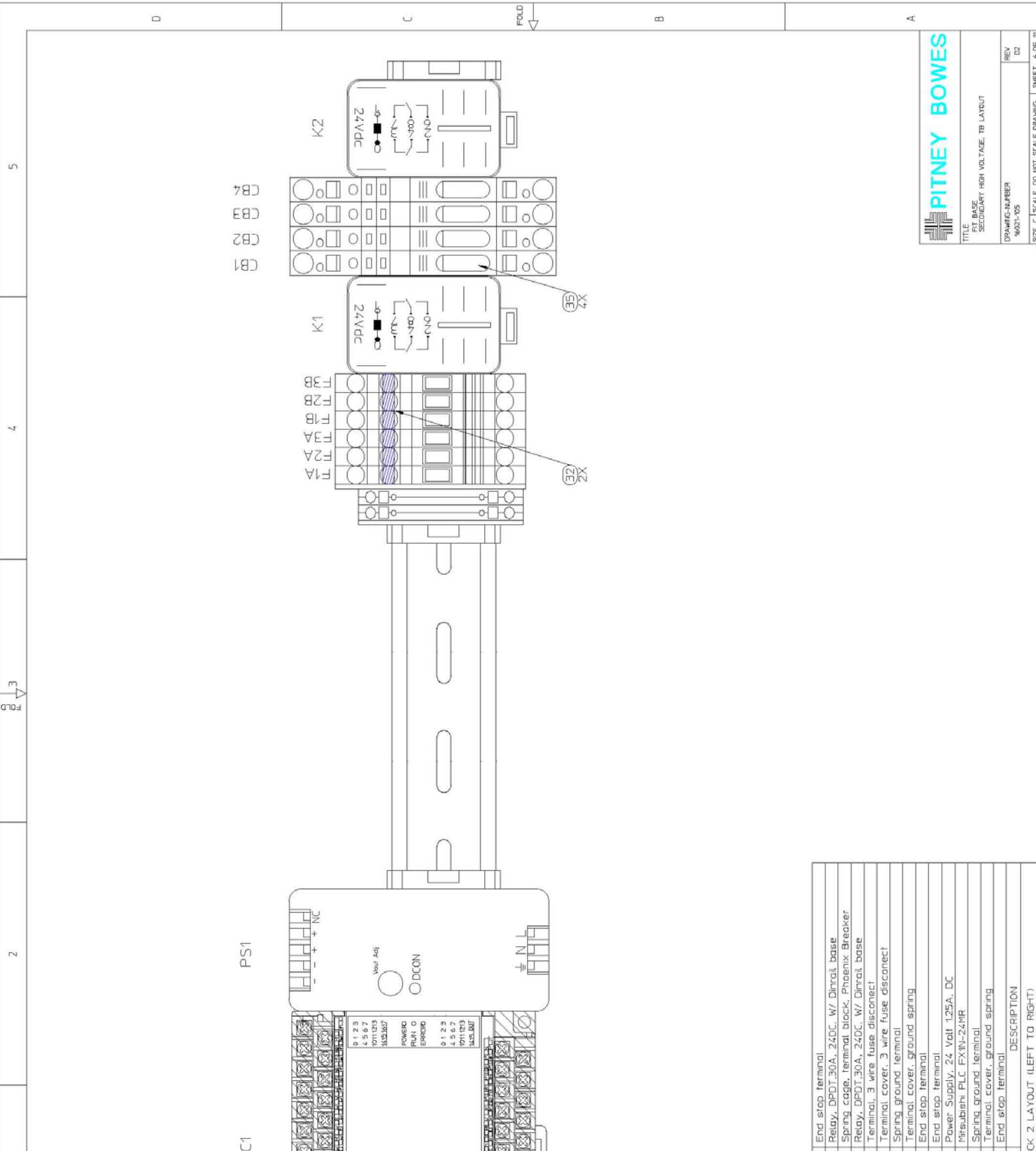

**PITNEY BOWES**

TITLE  
FIT BASE  
SECONDARY HIGH VOLTAGE, TB LAYOUT

DRAWING NUMBER  
46021-105

REV  
D2

SIZE C | SCALE DD | NOT SCALE DRAWING | SHEET 6 OF 91

MANUFACTURER'S P/N	QTY	DESCRIPTION
249-116	1	End stop terminal
850-0347	1	Relay, DPDT, 30A, 24DC, w/ Dinrail base
3036372	4	Spring cage, terminal block, Phoenix Breaker
850-0347	1	Relay, DPDT, 30A, 24DC, w/ Dinrail base
281-610	6	Terminal, 3 wire fuse disconnect
281-324	1	Terminal cover, 3 wire fuse disconnect
880-907	2	Spring ground terminal
880-325	1	Terminal cover, ground spring
249-116	1	End stop terminal
SPD2430IB	1	Power Supply, 24 Volt 1.25A, DC
C, FX1N-24, MR-ES/UL	1	Mitsubishi PLC FX1N-24MR
880-907	2	Spring ground terminal
880-325	1	Terminal cover, ground spring
249-116	1	End stop terminal

TERMINAL BLOCK 2 LAYOUT (LEFT TO RIGHT)

1 record is the property of Pitney Bowes. This drawing is not to be copied, reproduced, or used in any way without the written consent of Pitney Bowes.

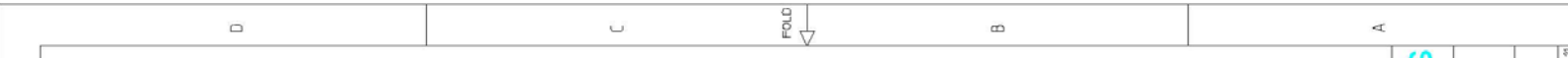

**PITNEY BOWES**  
 TITLE  
 FIT BASE  
 PRIMARY HIGH VOLTAGE TB LAYOUT  
 DRAWING NUMBER  
 6021-105  
 REV  
 D2  
 SIZE C SCALE DO NOT SCALE DRAWING | SHEET 7 OF 91

TB1

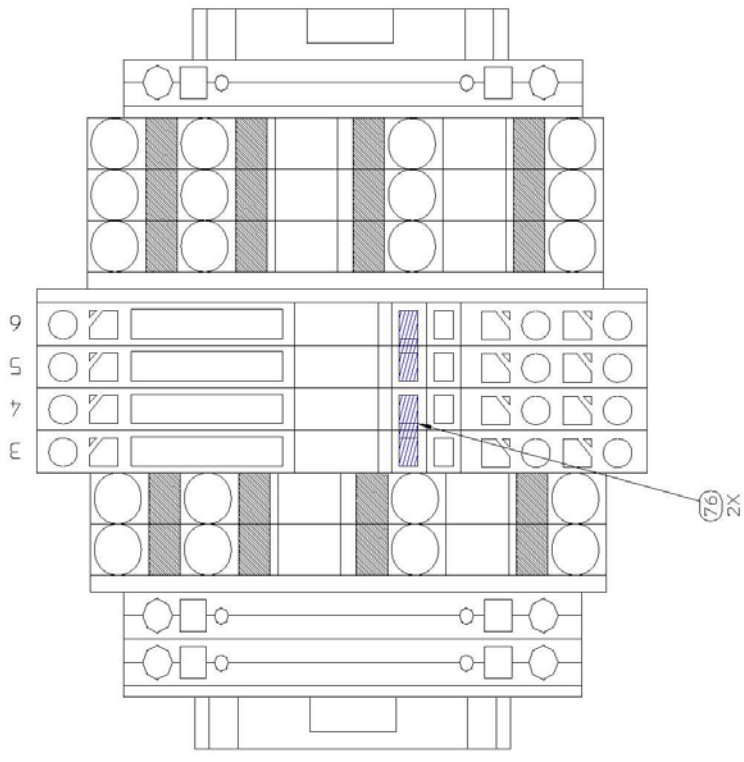

UFACTOR'S P/N	QTY	DESCRIPTION
249-116	1	End stop terminal
860-907	1	Spring ground terminal
860-325	1	End cover, ground terminal
870-508	3	Terminal, dbl. layer shorted (4 way)
870-518	1	End cover, dbl. layer shorted (4 way)
3030514	1	Side cover, dual terminal block
3039448	4	Terminal block, dual, spring cage disconnect
870-508	2	Terminal, dbl. layer shorted (4 way)
870-518	1	End cover, dbl. layer shorted (4 way)
860-907	2	Spring ground terminal
860-325	1	End cover, ground terminal
249-116	1	End stop terminal

TERMINAL BLOCK LAYOUT (Left to Right)

1  
 record is the property of  
 Pitney Bowes. It is not to be  
 reproduced, stored, or  
 distributed in any form or  
 by any means, electronic,  
 mechanical, or otherwise,  
 without prior written  
 permission of Pitney Bowes.

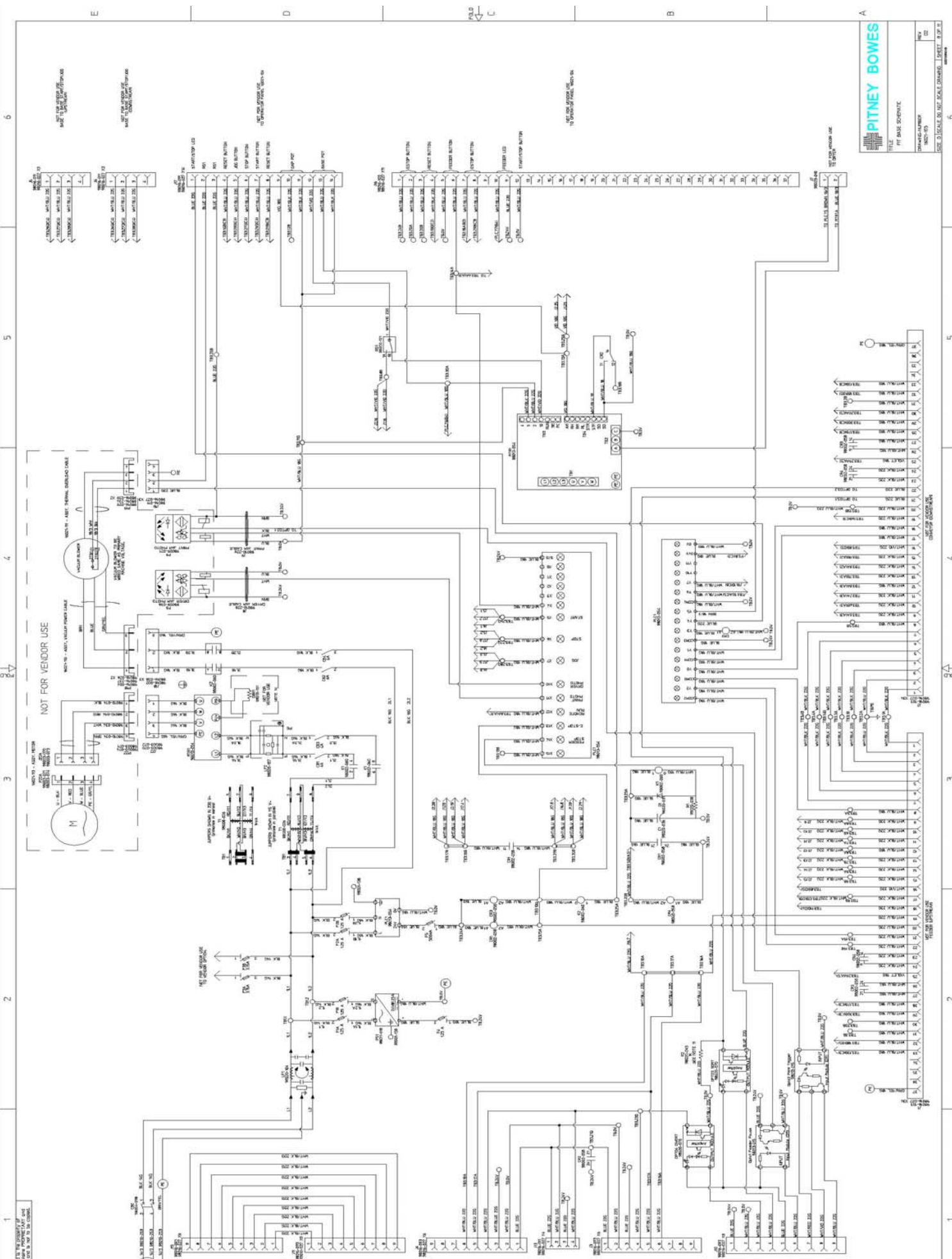

NOT FOR VENDOR USE

NOT FOR VENDOR USE

NOT FOR VENDOR USE

NOT FOR VENDOR USE

1

2

3

4

5

This record is the property of Pitney Bowes and should not be removed from the file and should not be copied.

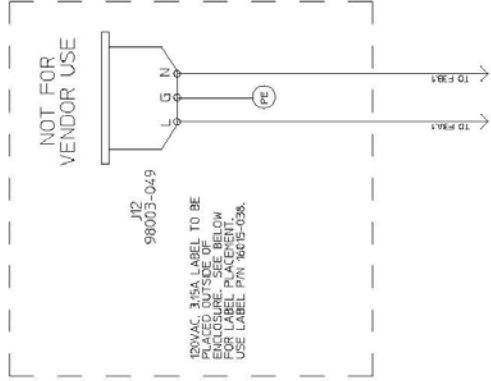

FRONT SIDE

RIGHT SIDE

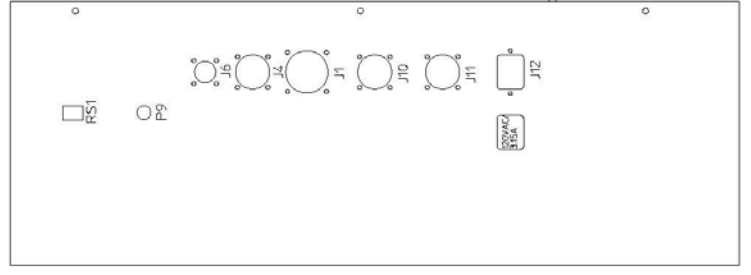
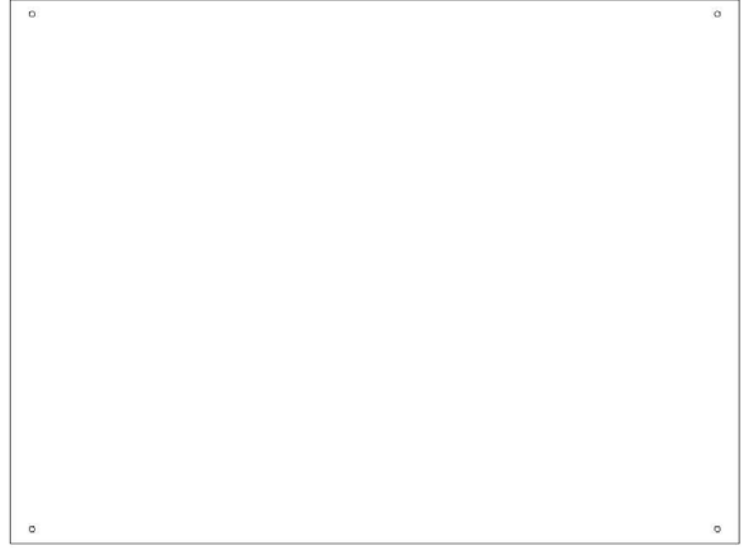

FOLD

D

C

B

A



TITLE	FIT BASE SECAP OPTION
DRAWING-NUMBER	REV
16021-005	D2
SIZE C, SCALE E.O. NOT SCALE DRAWING	SHEET 9 OF 11

1

2

4

5

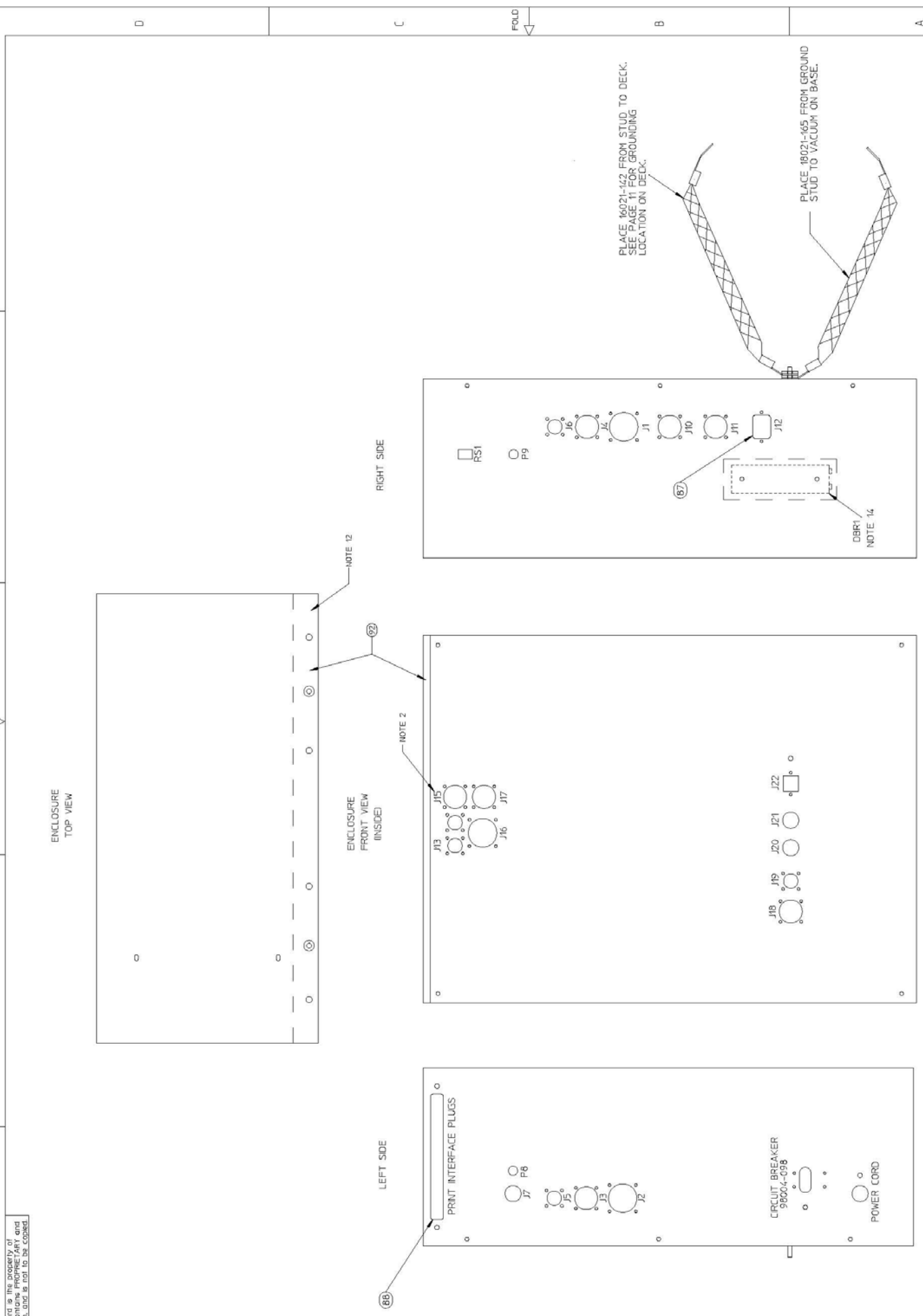

FOLD

PLACE 18021-162 FROM STUD TO DECK.  
SEE PAGE 11 FOR GROUNDING  
LOCATION ON DECK.

PLACE 18021-165 FROM GROUND  
STUD TO VACUUM ON BASE.

**PITNEY BOWES**

TITLE  
FIT BASE  
ENCLOSURE LAYOUT

DRAWING NUMBER  
16021-105

REV  
D2

SIZE C | SCALE 00 | NOT SCALE DRAWING | SHEET 10 OF 11

5

4

3

2

1

This record is the property of Pitney Bowes and should not be loaned, copied, or otherwise disposed of without the written consent of Pitney Bowes.

NOT FOR VENDOR USE  
SEE NOTE 13

GROUND TO DECK HERE WHEN MACHINE IS LEFT TO RIGHT (STANDARD). GROUND BY USING A 10-24 SCREW, AND A STAR WASHER.

16021-105 - CONTROL ENCLOSURE

GROUND CABLE

GROUND TO DECK HERE WHEN MACHINE IS RIGHT TO LEFT. GROUND BY USING A 10-24 SCREW, AND A STAR WASHER.

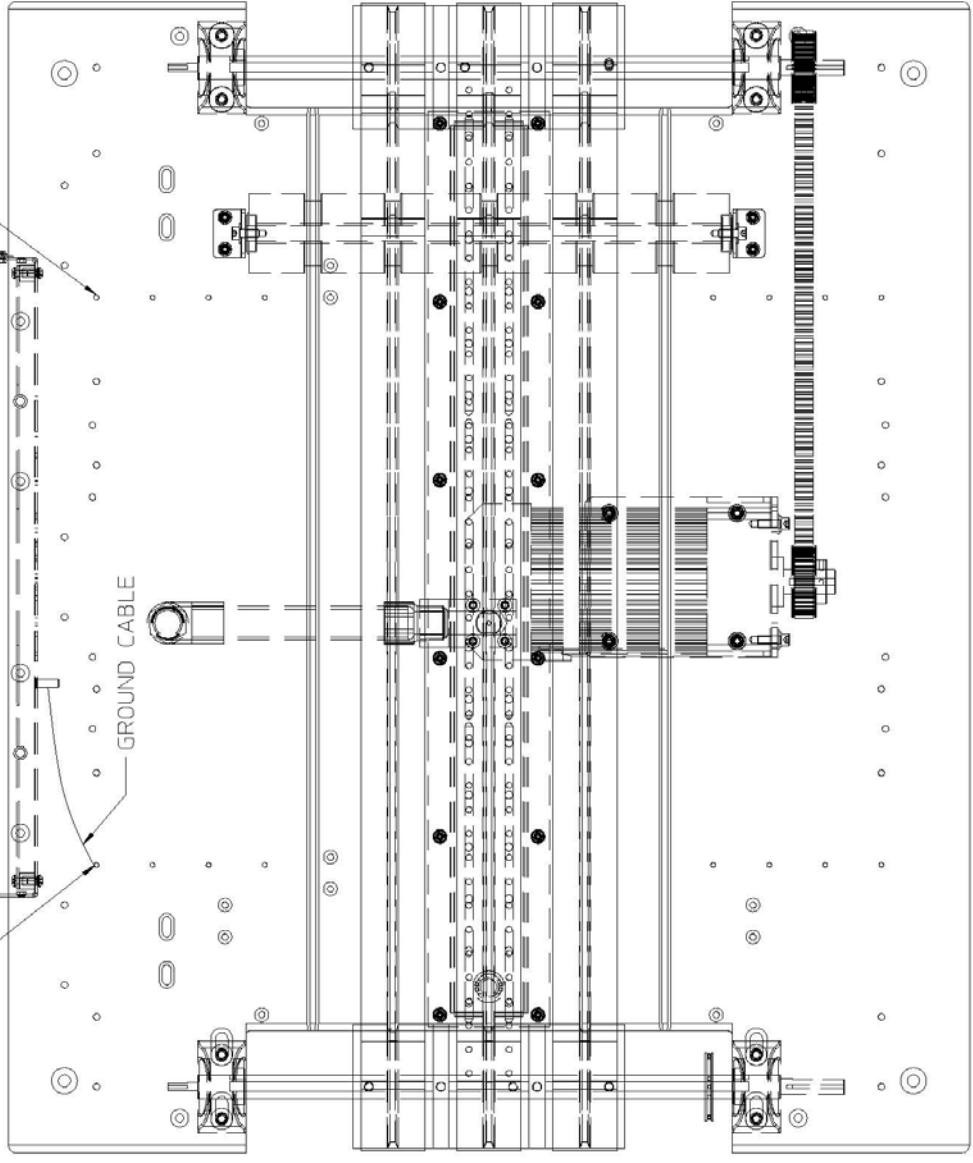

TITLE	FIT BASE GROUNDING
DRAWING NUMBER	16021-105
REV	D2
SIZE	C SCALE DO NOT SCALE DRAWING   SHEET 11 OF 11

# **Section VII**

## **Trouble Shooting**

### **FLEXIBLE INKJET TRANSPORT**

### **36" FIT BASE: FIT-36**

### **SERVICE MANUAL**



***DIRECT MAIL SOLUTIONS***

12050 49th STREET NORTH - CLEARWATER, FL. 33762-4301  
PHONE: 727.571.3330 - FAX: 727.571.3443 - TOLL FREE: 1.800.INSERTER  
web: [sure-feed.com](http://sure-feed.com)

## Troubleshooting

Problem:	Things to Check:
<b>No power to any component of machine</b>	Check Main Breaker (supply power) Check power connection to the machine
<b>No power to base electrical enclosure</b>	Check 10 amp Circuit Breaker (enclosure mounted-CB 0)
<b>No power to VFD</b>	Check 3 amp Circuit Breaker (back plate mounted-CB 1,3) Check K1 relay (MTR 1)
<b>No power to PLC</b>	Check F2A, 2B fuses 1.25A (input)
<b>No power to PS1 (DC Power Supply)</b>	Check F1A, 1B fuses 1.25A (input)
<b>Base Conveyor is not running (MTR 1)</b>	Check 10 amp Circuit Breaker is ON Check PLC: Switch to RUN – Lamp “RUN” is on. Check power to PLC, refer to “No Power PLC” Check Power to MTR1, refer to “No Power VFD” Check all E-stop buttons. Check that timing belts on drive motor and conveyors are not damaged, broken or missing
<b>Vacuum Motor does not operate</b>	Check 4 amp Circuit Breaker (input)-(CB 2, 4) Check K2 relay, engages the vacuum power. Check K1 relay (MTR 1) and Vacuum pump
<b>Feeder is not feeding (MTR 2)</b>	Check Feeder On/Off Button (Lamp illuminated = On) Check Connection at J1 receptacle Feeder needs to be full (Product sensors engaged) Check Y2 Output on PLC.



**PLC DIAGNOSTICS**

POWER RUN ERROR	Check power supply, ground and I/O cables are properly wired
POWER ■ RUN ERROR	Turn power supply ON. Check that the POWER LED is active. Down load a small test program onto the PLC.Using a programming device or PC with appropriate software, for each output ON/OFF. Check output LEDs for operation.
POWER ■ RUN ■ ERROR	Place the PLC into RUN mode and check that the RUN LED is active.

POWER ■ RUN ERROR ■	<b><u>REMEDY</u></b> Reset PLC- power OFF then ON, trigger RUN input.	<b><u>POSSIBLE RESULTS</u></b> <b>LED OFF:</b> Was memory cassette installed or removed when powered up?  <b>LED ON: GO TO STEP 1</b>
---------------------------	--	--

<b>STEP 1</b>	<b><u>REMEDY</u></b> Power OFF  Disconnect earth/ground terminal  Power ON	<b><u>POSSIBLE RESULTS</u></b> <b>LED Flashing:</b> Check for programming error. Ensure that earth/ground cable is correctly rewired.  <b>LED ON: GO TO STEP 2</b>
---------------	--	--

<b>STEP 2</b>	<b><u>REMEDY</u></b>  Possible program/scan time error. Check D8012	<b><u>POSSIBLE RESULTS</u></b>  <b>D8012&gt;D8000</b>
---------------	--	---

**COMMON ERRORS**

2. Corroded contact points at some point in an I/O wire.
3. An I/O device has been used outside its specified operating range.
4. An input signal is active for less time than one program scan.

**MAINTENANCE**

1. Check interior temperature of the panel.
2. Check for loose component mounting or wire terminations.

# **Section VIII**

## **Component Programming**

### **FLEXIBLE INKJET TRANSPORT**

#### **36” FIT BASE: FIT-36**

#### **SERVICE MANUAL**



***DIRECT MAIL SOLUTIONS***

12050 49th STREET NORTH - CLEARWATER, FL. 33762-4301  
PHONE: 727.571.3330 - FAX: 727.571.3443 - TOLL FREE: 1.800.INSERTER  
web: [sure-feed.com](http://sure-feed.com)

# FX SERIES PROGRAMMABLE CONTROLLER

Go to Mitsubishi website for latest updates and complete manual

## Programming Manual

Manual number : JY992D88101

Manual revision : D

Date : April 2003

### Guidelines for the Safety of the User and Protection of the Programmable Controller (PLC)

This manual provides information for the use of the FX family of PLC's. The manual has been written to be used by trained and competent personnel. The definition of such a person or persons is as follows;

- a) Any engineer who is responsible for the planning, design and construction of automatic equipment using the product associated with this manual should be of a competent nature, trained and qualified to the local and national standards required to fulfill that role. These engineers should be fully aware of all aspects of safety with regards to automated equipment.
- b) Any commissioning or service engineer must be of a competent nature, trained and qualified to the local and national standards required to fulfill that job. These engineers should also be trained in the use and maintenance of the completed product. This includes being completely familiar with all associated documentation for the said product. All maintenance should be carried out in accordance with established safety practices.
- c) All operators of the completed equipment (see Note) should be trained to use this product in a safe manner in compliance to established safety practices. The operators should also be familiar with documentation which is associated with the operation of the completed equipment.

**Note :** Note: the term 'completed equipment' refers to a third party constructed device which contains or uses the product associated with this manual.

### Notes on the Symbols Used in this Manual

At various times throughout this manual certain symbols will be used to highlight points of information which are intended to ensure the users personal safety and protect the integrity of equipment. Whenever any of the following symbols are encountered its associated note must be read and understood. Each of the symbols used will now be listed with a brief description of its meaning.

#### Hardware Warnings



1) Indicates that the identified danger **WILL** cause physical and property damage.



2) Indicates that the identified danger could **POSSIBLY** cause physical and property damage.



3) Indicates a point of further interest or further explanation.

#### Software Warnings



4) Indicates special care must be taken when using this element of software.



5) Indicates a special point which the user of the associate software element should be aware of.



6) Indicates a point of interest or further explanation.

# INVERTER FR-D700

MANUAL: IB(NA)0600368ENG-B 11/18/2008

Thank you for choosing this Mitsubishi Inverter.

This Instruction Manual provides instructions for advanced use of the FR-D700 series inverters.

Incorrect handling might cause an unexpected fault. Before using the inverter, always read this instruction manual and the Installation Guideline [IB-0600367ENG] packed with the product carefully to use the equipment to its optimum performance.

**This section is specifically about safety matters**

Do not attempt to install, operate, maintain or inspect the inverter until you have read through the Instruction Manual and appended documents carefully and can use the equipment correctly. Do not use this product until you have a full knowledge of the equipment, safety information and instructions.

In this Instruction Manual, the safety instruction levels are classified into "WARNING" and "CAUTION".

**⚠WARNING** Assumes that incorrect handling may cause hazardous conditions, resulting in death or severe injury.

**⚠CAUTION** Assumes that incorrect handling may cause hazardous conditions, resulting in medium or slight injury, or may cause physical damage only.

Note that even the **⚠CAUTION** level may lead to a serious consequence according to conditions. Please follow the instructions of both levels because these are important to personnel safety.

1. Electric Shock Prevention

**⚠WARNING**

- While power is on or when the inverter is running, do not open the front cover. Otherwise you may get an electric shock.
- Do not run the inverter with the front cover or wiring cover removed. Otherwise, you may access the exposed high-voltage terminals or the charging part of the circuitry and get an electric shock.
- Even if power is OFF, do not remove the front cover except for wiring or periodic inspection. You may access the charged inverter circuits and get an electric shock.
- Before starting wiring or inspection, switch OFF power, check to make sure that the operation panel indicator is off, wait for at least 10 minutes after the power supply has been switched OFF, and check that there are no residual voltage using a tester or the like. The capacitor is charged with high voltage for some time after power OFF and it is dangerous.
- This inverter must be earthed (grounded). Earthing (grounding) must conform to the requirements of national and local safety regulations and electrical code. (NEC section 250, IEC 536 class 1 and other applicable standards)  
Use a neutral-point earthed (grounded) power supply for 400V class inverter in compliance with EN standard.
- Any person who is involved in the wiring or inspection of this equipment should be fully competent to do the work.
- Always install the inverter before wiring. Otherwise, you may get an electric shock or be injured.
- Perform setting dial and key operations with dry hands to prevent an electric shock. Otherwise you may get an electric shock.
- Do not subject the cables to scratches, excessive stress, heavy loads or pinching. Otherwise, you may get an electric shock.
- Do not change the cooling fan while power is ON. It is dangerous to change the cooling fan while power is ON.
- Do not touch the printed circuit board with wet hands. Otherwise, you may get an electric shock.
- When measuring the main circuit capacitor capacity, the DC voltage is applied to the motor for 1s at powering OFF. Never touch the motor terminal, etc. right after powering OFF to prevent an electric shock.

2. Fire Prevention

**⚠CAUTION**

- Install the inverter on a nonflammable wall without holes (so that nobody can touch the inverter heatsink on the rear side, etc.). Mounting it to or near flammable material can cause a fire.
- If the inverter has become faulty, switch off the inverter power. A continuous flow of large current could cause a fire.
- When using a brake resistor, make up a sequence that will turn off power when an alarm signal is output. Otherwise, the brake resistor may excessively overheat due to damage of the brake transistor and such, causing a fire.
- Do not connect a resistor directly to the DC terminals P/+ and N/-. This could cause a fire.

### 3. Injury Prevention

<b>⚠ CAUTION</b>
<ul style="list-style-type: none"> <li>● Apply only the voltage specified in the instruction manual to each terminal. Otherwise, burst, damage, etc. may occur.</li> <li>● Ensure that the cables are connected to the correct terminals. Otherwise, burst, damage, etc. may occur.</li> <li>● Always make sure that polarity is correct to prevent damage, etc. Otherwise, burst, damage, etc. may occur.</li> <li>● While power is ON or for some time after power-OFF, do not touch the inverter since the inverter will be extremely hot. Doing so can cause burns.</li> </ul>

### 4. Additional Instructions

Also note the following points to prevent an accidental failure, injury, electric shock, etc.

#### (1) Transportation and mounting

<b>⚠ CAUTION</b>
<ul style="list-style-type: none"> <li>● Transport the product using the correct method that corresponds to the weight. Failure to observe this could lead to injuries.</li> <li>● Do not stack the inverter boxes higher than the number recommended.</li> <li>● Ensure that installation position and material can withstand the weight of the inverter. Install according to the information in the instruction manual.</li> <li>● Do not install or operate the inverter if it is damaged or has parts missing.</li> <li>● When carrying the inverter, do not hold it by the front cover or setting dial; it may fall off or fail.</li> <li>● Do not stand or rest heavy objects on the product.</li> <li>● Check the inverter mounting orientation is correct.</li> <li>● Prevent other conductive bodies such as screws and metal fragments or other flammable substance such as oil from entering the inverter.</li> <li>● As the inverter is a precision instrument, do not drop or subject it to impact.</li> <li>● Use the inverter under the following environmental conditions: Otherwise, the inverter may be damaged.</li> </ul>

Environment	Surrounding air temperature	-10°C to +50°C (14°F to 122°F) (non-freezing)
	Ambient humidity	90% RH or less (non-condensing)
	Storage temperature	-20°C to +65°C (-4°F to 149°F) *1
	Atmosphere	Indoors (free from corrosive gas, flammable gas, oil mist, dust and dirt)
	Altitude/vibration	Maximum 1000m (3280.80feet) above sea level for standard operation. After that derate by 3% for every extra 500m (1640.40feet) up to 2500m (8202feet) (91%). 5.9m/s <sup>2</sup> or less at 10 to 55Hz (directions of X, Y, Z axes)

\*1 Temperature applicable for a short time, e.g. in transit.

#### (2) Wiring

<b>⚠ CAUTION</b>
<ul style="list-style-type: none"> <li>● Do not install a power factor correction capacitor or surge suppressor/capacitor type filter on the inverter output side. These devices on the inverter output side may be overheated or burn out.</li> <li>● The connection orientation of the output cables U, V, W to the motor will affect the direction of rotation of the motor.</li> </ul>

#### (3) Trial run

<b>⚠ CAUTION</b>
<ul style="list-style-type: none"> <li>● Before starting operation, confirm and adjust the parameters. A failure to do so may cause some machines to make unexpected motions.</li> </ul>

#### (4) Usage

<b>⚠ WARNING</b>
<ul style="list-style-type: none"> <li>● When you have chosen the retry function, stay away from the equipment as it will restart suddenly after trip.</li> <li>● Since pressing  key may not stop output depending on the function setting status, provide a circuit and switch separately to make an emergency stop (power OFF, mechanical brake operation for emergency stop, etc).</li> <li>● Make sure that the start signal is off before resetting the inverter alarm. A failure to do so may restart the motor suddenly.</li> <li>● The load used should be a three-phase induction motor only. Connection of any other electrical equipment to the inverter output may damage the equipment.</li> <li>● Do not modify the equipment.</li> <li>● Do not perform parts removal which is not instructed in this manual. Doing so may lead to fault or damage of the product.</li> </ul>

<b>⚠ CAUTION</b>
<ul style="list-style-type: none"> <li>● The electronic thermal relay function does not guarantee protection of the motor from overheating. It is recommended to install both an external thermal and PTC thermistor for overheat protection.</li> <li>● Do not use a magnetic contactor on the inverter input for frequent starting/stopping of the inverter. Otherwise, the life of the inverter decreases.</li> <li>● Use a noise filter to reduce the effect of electromagnetic interference. Otherwise nearby electronic equipment may be affected.</li> <li>● Take measures to suppress harmonics. Otherwise power supply harmonics from the inverter may heat/damage the power factor correction capacitor and generator.</li> <li>● When a 400V class motor is inverter-driven, please use an insulation-enhanced motor or measures taken to suppress surge voltages. Surge voltages attributable to the wiring constants may occur at the motor terminals, deteriorating the insulation of the motor.</li> <li>● When parameter clear or all parameter clear is performed, reset the required parameters before starting operations. Each parameter returns to the initial value.</li> <li>● The inverter can be easily set for high-speed operation. Before changing its setting, fully examine the performances of the motor and machine.</li> <li>● In addition to the inverter's holding function, install a holding device to ensure safety.</li> <li>● Before running an inverter which had been stored for a long period, always perform inspection and test operation.</li> <li>● For prevention of damage due to static electricity, touch nearby metal before touching this product to eliminate static electricity from your body.</li> </ul>

**(5) Emergency stop**

** CAUTION**

- Provide a safety backup such as an emergency brake which will prevent the machine and equipment from hazardous conditions if the inverter fails.
- When the breaker on the inverter input side trips, check for the wiring fault (short circuit), damage to internal parts of the inverter, etc. Identify the cause of the trip, then remove the cause and power ON the breaker.
- When any protective function is activated, take the appropriate corrective action, then reset the inverter, and resume operation.

**(6) Maintenance, inspection and parts replacement**

** CAUTION**

- Do not carry out a megger (insulation resistance) test on the control circuit of the inverter. It will cause a failure.

**(7) Disposal**

** CAUTION**

- Treat as industrial waste.

**General instruction**

Many of the diagrams and drawings in this Instruction Manual show the inverter without a cover, or partially open. Never operate the inverter in this manner. Always replace the cover and follow this Instruction Manual when operating the inverter.

## ● Removal (Example of FR-D740-036)

- 1) Loosen the installation screws of the front cover. (The screws cannot be removed.)
- 2) Remove the front cover by pulling it like the direction of arrow.

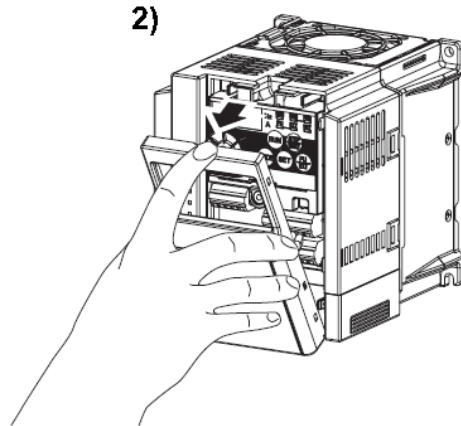
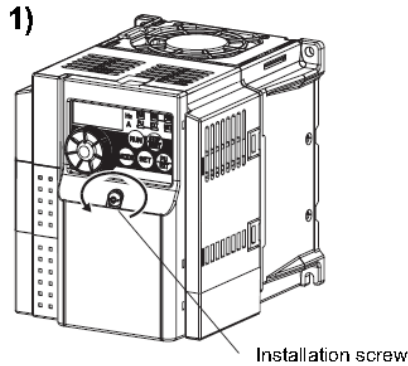

## ● Reinstallation (Example of FR-D740-036)

- 1) Place the front cover in front of the inverter, and install it straight.
- 2) Tighten the installation screws on the front cover.

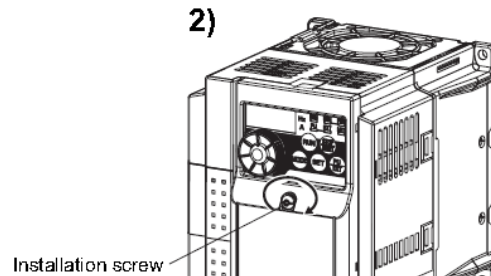
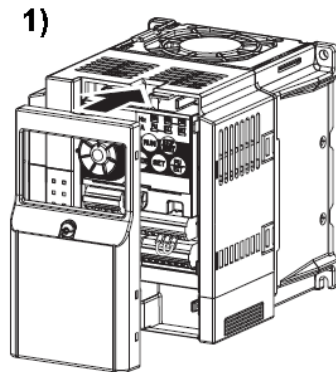

- Hold the side of the wiring cover, and pull it downward for removal.  
To reinstall, fit the cover to the inverter along the guides.

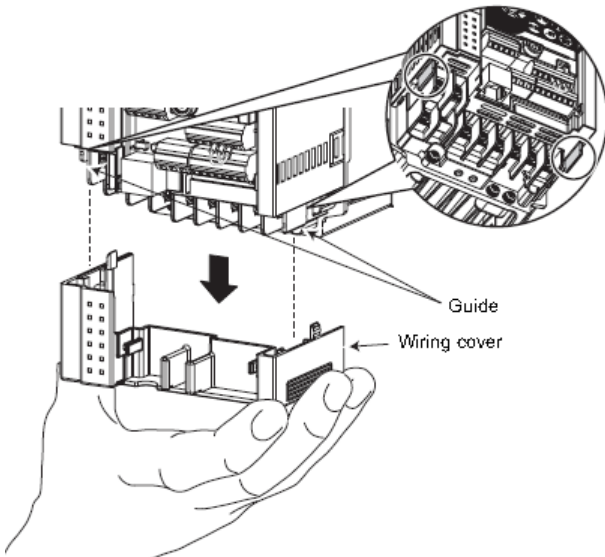

- Also pull the wiring cover downward with holding a frontal part of the wiring cover.

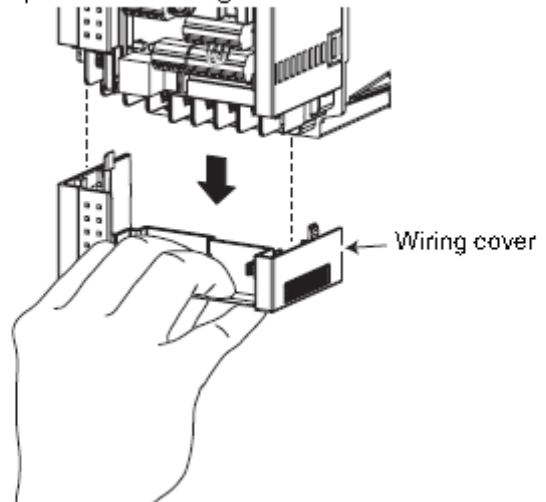



Environmental standard specifications of inverter

Item	Description
Surrounding air temperature	-10°C to +50°C (14°F to 122°F) (non-freezing)
Ambient humidity	90%RH or less (non-condensing)
Atmosphere	Free from corrosive and explosive gases, free from dust and dirt
Maximum altitude	1,000m (3280.80 feet) or less
Vibration	5.9m/s <sup>2</sup> or less at 10 to 55Hz (directions of X, Y, Z axes)

Use the inverter at the altitude of within 1000m (3280.80 feet). If it is used at a higher place, it is likely that thin air will reduce the cooling effect and low air pressure will deteriorate dielectric strength.

Maximum 1000m (3280.80feet) above sea level for standard operation. After that derate by 3% for every extra 500m (1640.40feet) up to 2500m (8202feet) (91%).

2.1.1 Terminal connection diagram

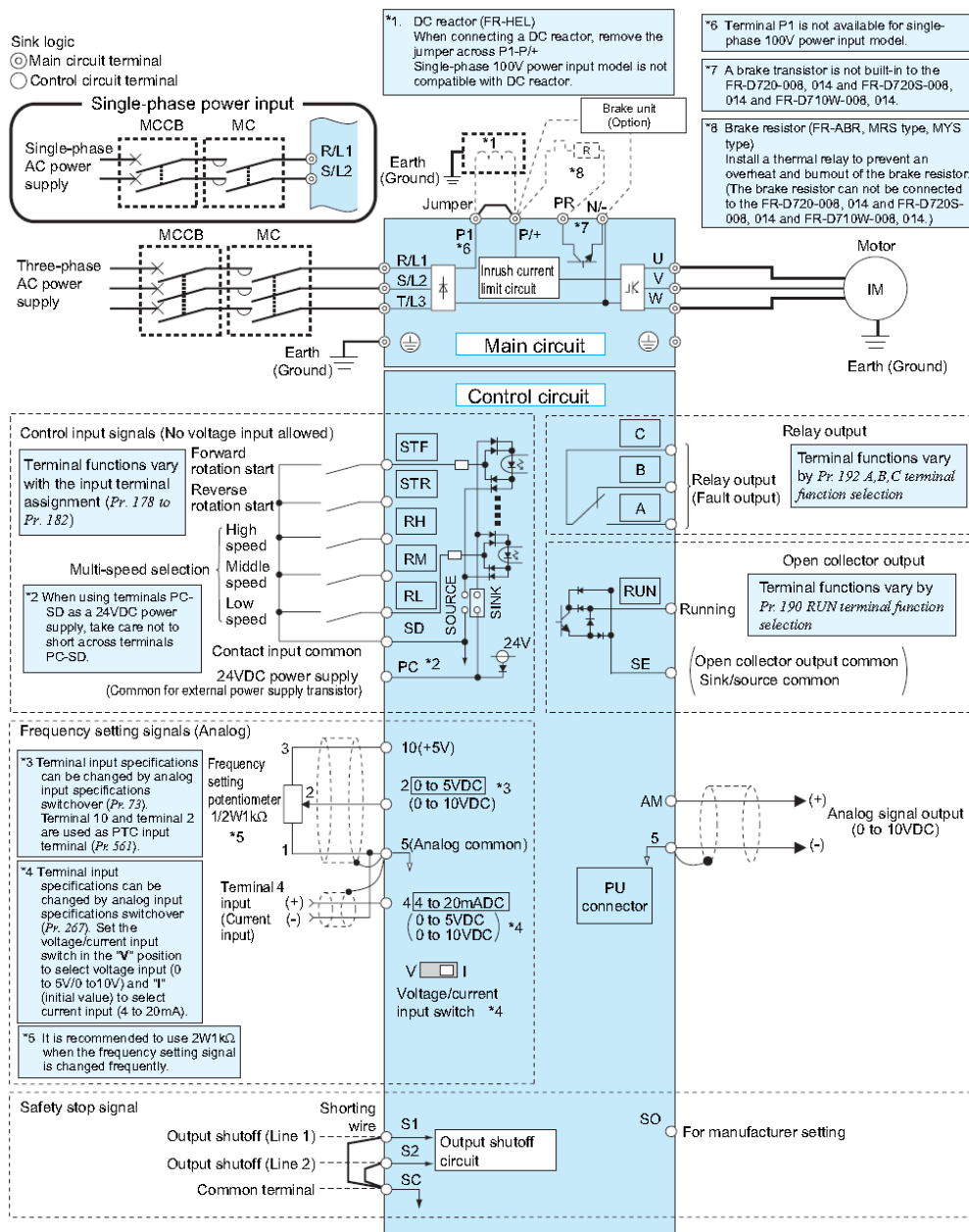

● **Single-phase 200V class**

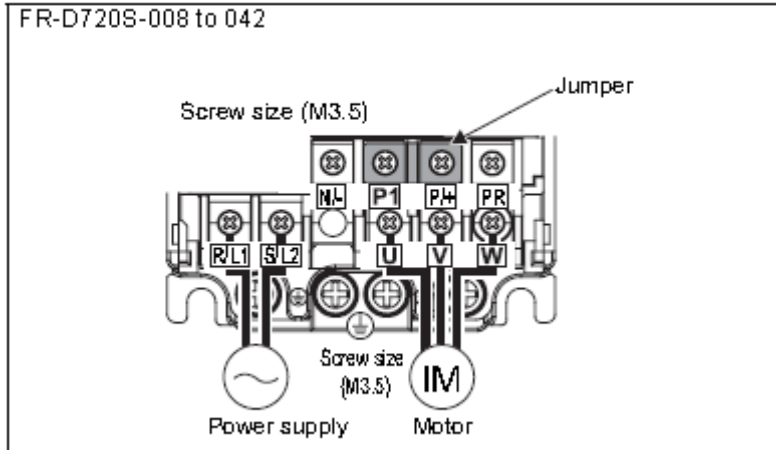

**(2) Earthing (Grounding) precautions**

- Always earth (ground) the motor and inverter.

1) Purpose of earthing (grounding)

Generally, an electrical apparatus has an earth (ground) terminal, which must be connected to the ground before use. An electrical circuit is usually insulated by an insulating material and encased. However, it is impossible to manufacture an insulating material that can shut off a leakage current completely, and actually, a slight current flow into the case. The purpose of earthing (grounding) the case of an electrical apparatus is to prevent operator from getting an electric shock from this leakage current when touching it.

To avoid the influence of external noises, this earthing (grounding) is important to audio equipment, sensors, computers and other apparatuses that handle low-level signals or operate very fast.

2) Earthing (grounding) methods and earthing (grounding) work

As described previously, earthing (grounding) is roughly classified into an electrical shock prevention type and a noise-affected malfunction prevention type. Therefore, these two types should be discriminated clearly, and the following work must be done to prevent the leakage current having the inverter's high frequency components from entering the malfunction prevention type earthing (grounding):

- (a) Where possible, use independent earthing (grounding) for the inverter. If independent earthing (grounding) (I) is impossible, use joint earthing (grounding) (II) where the inverter is connected with the other equipment at an earthing (grounding) point. Joint earthing (grounding) as in (III) must be avoided as the inverter is connected with the other equipment by a common earth (ground) cable.

Also a leakage current including many high frequency components flows in the earth (ground) cables of the inverter and inverter-driven motor. Therefore, use the independent earthing (grounding) method and be separated from the earthing (grounding) of equipment sensitive to the aforementioned noises.

In a tall building, it will be a good policy to use the noise malfunction prevention type earthing (grounding) with steel frames and carry out electric shock prevention type earthing (grounding) in the independent earthing (grounding) method.

- (b) This inverter must be earthed (grounded). Earthing (Grounding) must conform to the requirements of national and local safety regulations and electrical codes. (NEC section 250, IEC 536 class 1 and other applicable standards).

- (c) Use the thickest possible earth (ground) cable. The earth (ground) cable should be of not less than the size indicated in the table on the previous page 17.

- (d) The earthing (grounding) point should be as near as possible to the inverter, and the earth (ground) cable length should be as short as possible.

- (e) Run the earth (ground) cable as far away as possible from the I/O wiring of equipment sensitive to noises and run them in parallel in the minimum distance.

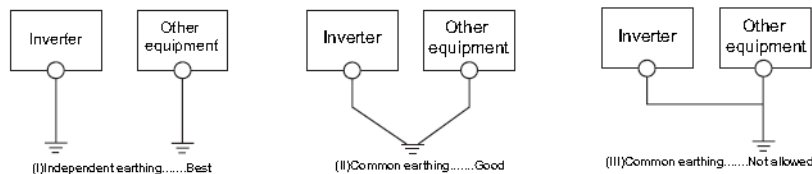

**POINT**

To be compliant with the European Directive (Low Voltage Directive), refer to the Installation Guideline.

## 2.3.2 Changing the control logic

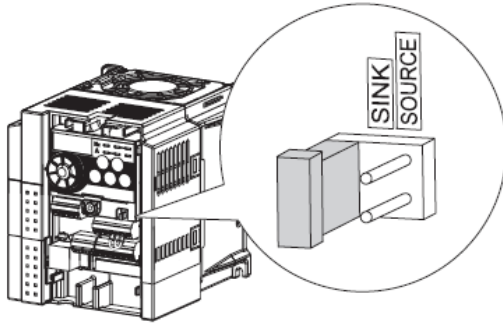

The input signals are set to sink logic (SINK) when shipped from the factory.

To change the control logic, the jumper connector above the control terminal must be moved to the other position.

- Change the jumper connector in the sink logic (SINK) position to source logic (SOURCE) position using tweezers, a pair of long-nose pliers etc. Change the jumper connector position before switching power ON.

### (1) Standard control circuit terminal layout

Recommend wire size:  
0.3mm<sup>2</sup> to 0.75mm<sup>2</sup>

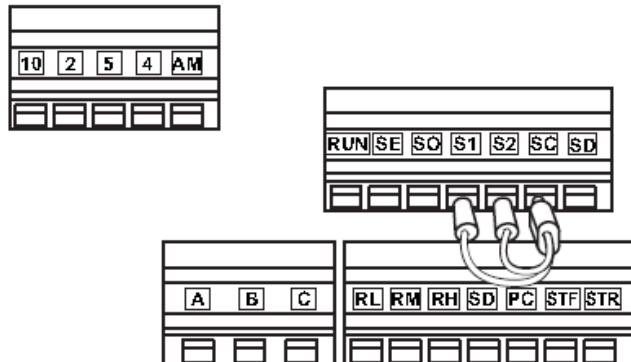

### ●RS-485 communication

When the PU connector is connected with a personal, FA or other computer by a communication cable, a user program can run and monitor the inverter or read and write to parameters.

The protocol can be selected from Mitsubishi inverter and Modbus RTU.

### • PU connector pin-outs

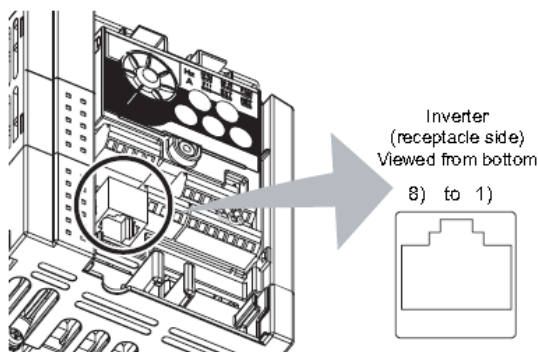

Pin Number	Name	Description
1)	SG	Earth (ground) (connected to terminal 5)
2)	—	Parameter unit power supply
3)	RDA	Inverter receive+
4)	SDB	Inverter send-
5)	SDA	Inverter send+
6)	RDB	Inverter receive-
7)	SG	Earth (ground) (connected to terminal 5)
8)	—	Parameter unit power supply

### NOTE

- Pins No. 2 and 8 provide power to the parameter unit. Do not use these pins for RS-485 communication.
- When making RS-485 communication between the FR-D700 series, FR-E500 series and FR-S500 series, incorrect connection of pins No.2 and 8 (parameter unit power supply) of the above PU connector may result in the inverter malfunction or failure.
- Do not connect the PU connector to the computer's LAN board, FAX modem socket or telephone modular connector. The product could be damaged due to differences in electrical specifications.

## 3.5 Precautions for use of the inverter

---

The FR-D700 series is a highly reliable product, but incorrect peripheral circuit making or operation/handling method may shorten the product life or damage the product.

Before starting operation, always recheck the following items.

- (1) Use crimping terminals with insulation sleeve to wire the power supply and motor.
- (2) Application of power to the output terminals (U, V, W) of the inverter will damage the inverter. Never perform such wiring.
- (3) After wiring, wire offcuts must not be left in the inverter.  
Wire offcuts can cause an alarm, failure or malfunction. Always keep the inverter clean.  
When drilling mounting holes in an enclosure etc., take care not to allow chips and other foreign matter to enter the inverter.
- (4) Use cables of the size to make a voltage drop 2% maximum.  
If the wiring distance is long between the inverter and motor, a main circuit cable voltage drop will cause the motor torque to decrease especially at the output of a low frequency.  
Refer to *page 17* for the recommended wire sizes.
- (5) The overall wiring length should be 500m (1640.42feet) maximum.  
Especially for long distance wiring, the fast-response current limit function may decrease or the equipment connected to the secondary side may malfunction or become faulty under the influence of a charging current due to the stray capacity of the wiring. Therefore, note the overall wiring length. (*Refer to page 19*)
- (6) Electromagnetic wave interference  
The input/output (main circuit) of the inverter includes high frequency components, which may interfere with the communication devices (such as AM radios) used near the inverter. In this case, install the FR-BIF optional capacitor type filter (for use in the input side only) or FR-BSF01 or FR-BLF common mode filter to minimize interference.
- (7) Do not install a power factor correction capacitor, surge suppressor or capacitor type filter on the inverter output side.  
This will cause the inverter to trip or the capacitor and surge suppressor to be damaged. If any of the above devices are connected, immediately remove them. (When using capacitor type filter (FR-BIF) for a single-phase power input model, make sure of secure insulation of T/L3-phase, and connect to the input side of the inverter.)
- (8) For some short time after the power is switched OFF, a high voltage remains in the smoothing capacitor. When accessing the inverter for inspection, wait for at least 10 minutes after the power supply has been switched off, and then make sure that the voltage across the main circuit terminals P/+ and N/- of the inverter is not more than 30VDC using a tester, etc. The capacitor is charged with high voltage for some time after power off and it is dangerous.
- (9) A short circuit or earth (ground) fault on the inverter output side may damage the inverter modules.
  - Fully check the insulation resistance of the circuit prior to inverter operation since repeated short circuits caused by peripheral circuit inadequacy or an earth (ground) fault caused by wiring inadequacy or reduced motor insulation resistance may damage the inverter modules.
  - Fully check the to-earth (ground) insulation and phase to phase insulation of the inverter output side before power-on. Especially for an old motor or use in hostile atmosphere, securely check the motor insulation resistance etc.
- (10) Do not use the inverter input side magnetic contactor to start/stop the inverter.  
Always use the start signal (turn ON/OFF STF and STR signals) to start/stop the inverter. (*Refer to page 42*)
- (11) Across P/+ and PR terminals, connect only an external regenerative brake discharging resistor.  
Do not connect a mechanical brake.  
The brake resistor can not be connected to the FR-D720-008 and 014, FR-D720S-008 and 014, FR-D710W-008 and 014. Never short between terminals P/+ and PR.

(12) Do not apply a voltage higher than the permissible voltage to the inverter I/O signal circuits.  
 Application of a voltage higher than the permissible voltage to the inverter I/O signal circuits or opposite polarity damage the I/O devices. Especially check the wiring to prevent the speed setting potentiometer from being connected incorrectly to short terminals 10-5.

(13) Provide electrical and mechanical interlocks for MC1 and MC2 which are used for bypass operation. When the wiring is incorrect and if there is a bypass operation circuit as shown right, the inverter will be damaged due to arcs generated at the time of switch-over or chattering caused by a sequence error.

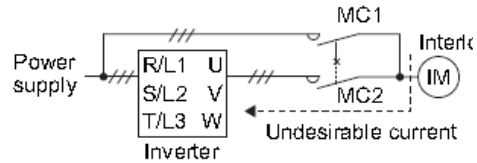

(14) If the machine must not be restarted when power is restored after a power failure, provide a magnetic contactor in inverter's input side and also make up a sequence which will not switch ON the start signal.  
 If the start signal (start switch) remains ON after a power failure, the inverter will automatically restart as soon as power is restored.

(15) Instructions for overload operation

When performing operation of frequent start/stop of the inverter, rise/fall in the temperature of the transistor element the inverter will repeat due to a repeated flow of large current, shortening the life from thermal fatigue. Since the fatigue is related to the amount of current, the life can be increased by reducing current at locked condition, starting current, etc. Decreasing current may increase the life. However, decreasing current will result in insufficient torque the inverter may not start. Therefore, choose the inverter which has enough allowance for current (up to 2 rank large capacity).

(16) Make sure that the specifications and rating match the system requirements.

(17) When the motor speed is unstable, due to change in the frequency setting signal caused by electromagnetic noises in the inverter, take the following measures while applying the motor speed by the analog signal.

- Do not run the signal cables and power cables (inverter I/O cables) in parallel with each other and do not bundle them.
- Run signal cables as far away as possible from power cables (inverter I/O cables).
- Use shield cables as signal cables.
- Install a ferrite core on the signal cable (Example: ZCAT3035-1330 TDK).

## 4.1.1 Names and functions of the operation panel

The operation panel cannot be removed from the inverter.

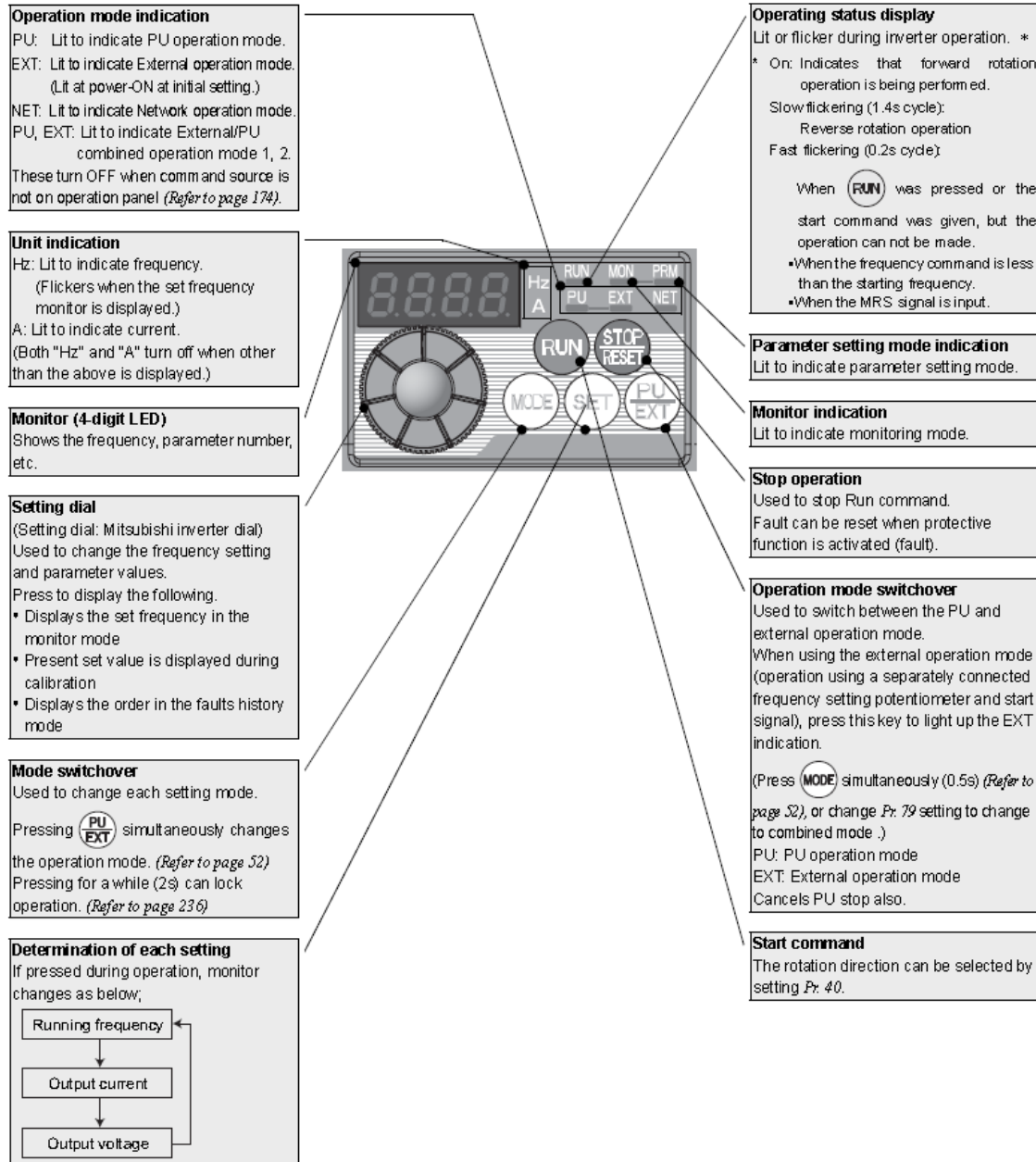

4.1.2 Basic operation (factory setting)

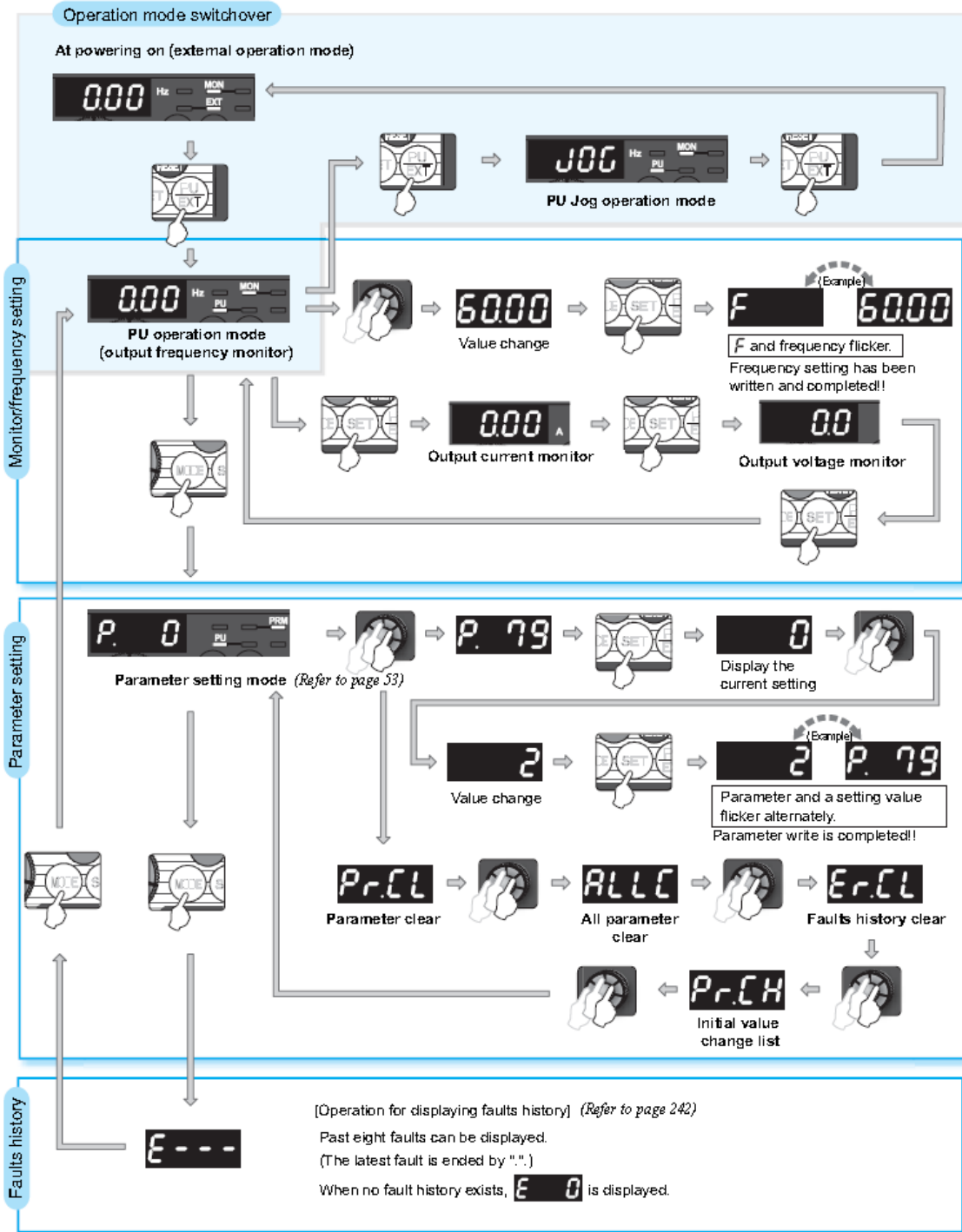



## 4.1.3 Easy operation mode setting (easy setting mode)

Setting of Pr. 79 Operation mode selection according to combination of the start command and speed command can be easily made.



Changing example









Start command: external (STF/STR), frequency command: operate with 

- Operation**





  1. Screen at powering on  
The monitor display appears.
  2. Press  and  for 0.5s.
  3. Turn  until 79-3 appears.  
(refer to the table below for other settings)

**Display**







  

  

Operation Panel Indication	Operation Method	
	Start command	Frequency command
		
	External (STF, STR)	Analog voltage input
	External (STF, STR)	
		Analog voltage input

4. Press  to set.
 

 →  
  
 Flicker ... Parameter setting complete!!  
 The monitor display appears after 3s.
- 

### REMARKS

- ? Er-1 is displayed ... Why?
  -  Parameter write is disabled with "1" set in Pr. 77.
- ? Er-2 is displayed ... Why?
  -  Setting can not be made during operation. Turn the start switch (, STF or STR) OFF.
- Press  before pressing  to return to the monitor display without setting. In this case, the mode changes to external operation mode when performed in the PU operation mode (PU JOG operation mode) and to PU operation mode when performed in the external operation mode.
- Reset can be made with .
- The priorities of the frequency commands when Pr. 79 = "3" are "Multi-speed operation (RURM/RH/REX) > PID control (X14) > terminal 4 analog input (AU) > digital input from the operation panel".



**4.1.4 Change the parameter setting value**

Changing example

Change the Pr. 1 Maximum frequency setting.

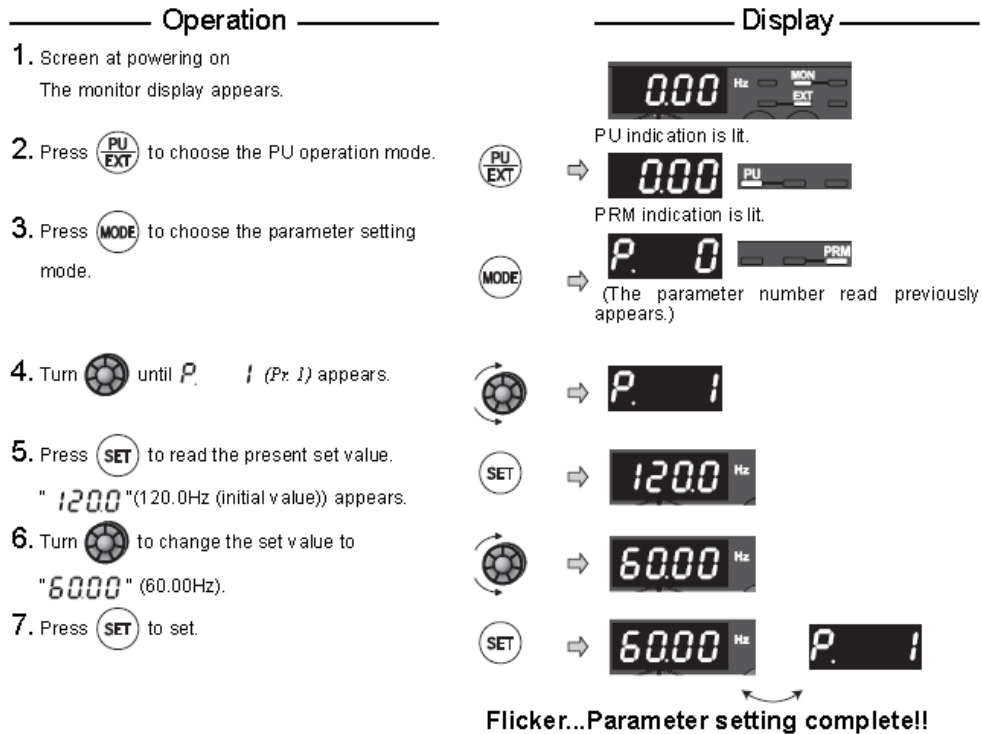

- Turn to read another parameter.
- Press **SET** to show the setting again.
- Press **SET** twice to show the next parameter.
- Press **MODE** twice to return to frequency monitor.

**REMARKS**

? **Er 1** to **Er 4** is displayed...Why?

- Er 1** appears..... Write disable error
- Er 2** appears..... Write error during operation
- Er 3** appears..... Calibration error
- Er 4** appears..... Mode designation error

(For details, refer to page 248.)

- The number of digits displayed on the operation panel is four. Only the upper four digits of v values can be displayed and set v values to be displayed have five digits or more including decimal places, the fifth or later numerals can not be displayed n.  
(Example) For Pr. 1  
When 60Hz is set, 60.00 is displayed.  
When 120Hz is set, 120.0 is displayed and second decimal place is not displayed nor set.

**4.1.5 Setting dial push**

Push the setting dial ( ) to display the set frequency\* currently set.

\* Appears when PU operation mode or external/PU combined operation mode 1 is selected (Pr. 79="3").

Selected St.: 00 FR-D720S-042-NA Date:5/7/2009

All Parameter List

FIT-36 base VFD rev.2\_19\_09

No.	Name	Setting Range	Unit	Initial	Current	Setting	Comment
0	Torque boost	0 to 30%	0.1%	6	6		
1	Maximum frequency	0 to 120Hz	0.01Hz	120	120	<b>71</b>	
>2	Minimum frequency	0 to 120Hz	0.01Hz	0	10	<b>10</b>	
3	Base frequency	0 to 400Hz	0.01Hz	60	60		
4	Multi-speed setting (high speed)	0 to 400Hz	0.01Hz	60	60		
5	Multi-speed setting (middle speed)	0 to 400Hz	0.01Hz	30	30		
6	Multi-speed setting (low speed)	0 to 400Hz	0.01Hz	10	10		
>7	Acceleration time	0 to 3600s	0.1s	5	0.8	<b>0.8</b>	
>8	Deceleration time	0 to 3600s	0.1s	5	0.7	<b>0.7</b>	
>9	Electronic thermal O/L	0 to 500A	0.01A	4.2	1.9	<b>2.3</b>	
>10	DC injection brake operation frequency	0 to 120Hz	0.01Hz	3	100	<b>100</b>	
>11	DC injection brake operation time	0 to 10s	0.1s	0.5	0.1	<b>0.1</b>	
>12	DC injection brake operation voltage	0 to 30%	0.1%	4	0	<b>0</b>	
13	Starting frequency	0 to 60Hz	0.01Hz	0.5	0.5		
14	Load pattern selection	0 to 3	1	0	0		
15	Jog frequency	0 to 400Hz	0.01Hz	5	5		
16	Jog acceleration/deceleration time	0 to 3600s	0.1s	0.5	0.5		
17	MRS input selection	0,2,4	1	0	0		
18	High speed maximum frequency	120 to 400Hz	0.01Hz	120	120	<b>71</b>	
19	Base frequency voltage	0 to 1000V,8888,9999	0.1V	9999	9999		
>20	Acceleration/deceleration reference frequency	1 to 400Hz	0.01Hz	60	120	<b>71</b>	
22	Stall prevention operation level	0 to 200%	0.1%	150	150		
23	Stall prevention operation level compensation factor at double speed	0 to 200%,9999	0.1%	9999	9999		
24	Multi-speed setting (speed 4)	0 to 400Hz,9999	0.01Hz	9999	9999		
25	Multi-speed setting (speed 5)	0 to 400Hz,9999	0.01Hz	9999	9999		
26	Multi-speed setting (speed 6)	0 to 400Hz,9999	0.01Hz	9999	9999		
27	Multi-speed setting (speed 7)	0 to 400Hz,9999	0.01Hz	9999	9999		
29	Acceleration/deceleration pattern selection	0,1,2	1	0	0		
30	Regenerative function selection	0,1,2	1	0	0		
31	Frequency jump 1A	0 to 400Hz,9999	0.01Hz	9999	9999		
32	Frequency jump 1B	0 to 400Hz,9999	0.01Hz	9999	9999		
33	Frequency jump 2A	0 to 400Hz,9999	0.01Hz	9999	9999		
34	Frequency jump 2B	0 to 400Hz,9999	0.01Hz	9999	9999		
35	Frequency jump 3A	0 to 400Hz,9999	0.01Hz	9999	9999		

Selected St.: 00 FR-D720S-042-NA Date:5/7/2009

All Parameter List

FIT-36 base VFD rev.2\_19\_09

No.	Name	Setting Range	Unit	Initial	Current	Setting	Comment
36	Frequency jump 3B	0 to 400Hz,9999	0.01Hz	9999	9999		
37	Speed display	0,0.01 to 9998	0.001	0	0		
40	RUN key rotation direction selection	0,1	1	0	0		
41	Up-to-frequency sensitivity	0 to 100%	0.1%	10	10		
42	Output frequency detection	0 to 400Hz	0.01Hz	6	6		
43	Output frequency detection for reverse rotation	0 to 400Hz,9999	0.01Hz	9999	9999		
44	Second acceleration/deceleration time	0 to 3600s	0.1s	5	5		
45	Second deceleration time	0 to 3600s,9999	0.1s	9999	9999		
46	Second torque boost	0 to 30%,9999	0.1%	9999	9999		
47	Second V/F (base frequency)	0 to 400Hz,9999	0.01Hz	9999	9999		
48	Second stall prevention operation current	0 to 200%,9999	0.1%	9999	9999		
51	Second electronic thermal O/L relay	0 to 500A,9999	0.01A	9999	9999		
52	DU/PU main display data selection	0,5,8 to 12,14,20,23 to 25,52 to 55,61,62,64,100	1	0	0		
>55	Frequency monitoring reference	0 to 400Hz	0.01Hz	60	120	<b>71</b>	
56	Current monitoring reference	0 to 500A	0.01A	4.2	4.2		
57	Restart coasting time	0,0.1 to 5s,9999	0.1s	9999	9999		
58	Restart cushion time	0 to 60s	0.1s	1	1		
59	Remote function selection	0,1,2,3	1	0	0		
60	Energy saving control selection	0,9	1	0	0		
65	Retry selection	0 to 5	1	0	0		
66	Stall prevention operation reduction starting	0 to 400Hz	0.01Hz	60	60		
67	Number of retries at fault occurrence	0 to 10,101 to 110	1	0	0		
68	Retry waiting time	0.1 to 600s	0.1s	1	1		
69	Retry count display erase	0	1	0	0		
70	Special regenerative brake duty	0 to 30%	0.1%	0	0		
71	Applied motor	0,1,3,13,23,40,43,50,53	1	0	0		
>72	PWM frequency selection	0 to 15	1	1	15	<b>15</b>	
73	Analog input selection	0,1,10,11	1	1	1		
74	Input filter time constant	0 to 8	1	1	1		
75	Reset selection/disconnected PU detection/PU stop selection	0 to 3,14 to 17	1	14	14		
>77	Parameter write selection	0,1,2	1	0	2	<b>2</b>	
78	Reverse rotation prevention selection	0,1,2	1	0	0		
79	Operation mode selection	0,1,2,3,4,6,7	1	0	0		
>80	Motor capacity	0.1 to 7.5kW,9999	0.01kW	9999	0.43	<b>0.43</b>	
82	Motor excitation current	0 to 500A,9999	0.01A	9999	9999		
>83	Rated motor voltage	0 to 1000V	0.1V	200	230	<b>230</b>	

Selected St.: 00 FR-D720S-042-NA Date:5/7/2009

All Parameter List

FIT-36 base VFD rev.2\_19\_09

No.	Name	Setting Range	Unit	Initial	Current	Setting	Comment
84	Rated motor frequency	10 to 120Hz	0.01Hz	60	60		
90	Motor constant (R1)	0 to 50ohm,9999	0.001ohm	9999	9999		
96	Auto tuning setting/status	0,11,21	1	0	0		
117	PU communication station number	0 to 31 (0 to 247)	1	0	0		
118	PU communication speed	48,96,192,384	1	192	192		
119	PU communication stop bit length	0,1,10,11	1	1	1		
120	PU communication parity check	0,1,2	1	2	2		
121	Number of PU communication retries	0 to 10,9999	1	1	1		
122	PU communication check time interval	0,0.1 to 999.8s,9999	0.1s	0	0		
123	PU communication waiting time setting	0 to 150ms,9999	1	9999	9999		
124	PU communication CR/LF selection	0,1,2	1	1	1		
>125	Terminal 2 frequency setting gain frequency	0 to 400Hz	0.01Hz	60	120	71	
126	Terminal 4 frequency setting gain frequency	0 to 400Hz	0.01Hz	60	60		
127	PID control automatic switchover frequency	0 to 400Hz,9999	0.01Hz	9999	9999		
128	PID action selection	0,20,21,40 to 43	1	0	0		
129	PID proportional band	0.1 to 1000%,9999	0.1%	100	100		
130	PID integral time	0.1 to 3600s,9999	0.1s	1	1		
131	PID upper limit	0 to 100%,9999	0.1%	9999	9999		
132	PID lower limit	0 to 100%,9999	0.1%	9999	9999		
133	PID action set point	0 to 100%,9999	0.01%	9999	9999		
134	PID differential time	0.01 to 10s,9999	0.01s	9999	9999		
145	PU display language selection	0 to 7	1	1	1		
>150	Output current detection level	0 to 200%	0.1%	150	100	100	
151	Output current detection signal delay time	0 to 10s	0.1s	0	0		
152	Zero current detection level	0 to 200%	0.1%	5	5		
153	Zero current detection time	0 to 1s	0.01s	0.5	0.5		
156	Stall prevention operation selection	0 to 31,100,101	1	0	0		
157	OL signal output timer	0 to 25s,9999	0.1s	0	0		
158	AM terminal function selection	1 to 3,5,8 to 12,14,21,24,52,53,61,62	1	1	1		
160	Extended function display selection	0,9999	1	0	0		
161	Frequency setting/key lock operation selection	0,1,10,11	1	0	0		
162	Automatic restart after instantaneous power failure selection	0,1,10,11	1	1	1		
165	Stall prevention operation level for restart	0 to 200%	0.1%	150	150		

Selected St.: 00 FR-D720S-042-NA Date:5/7/2009

All Parameter List

FIT-36 base VFD rev.2\_19\_09

No.	Name	Setting Range	Unit	Initial	Current	Setting	Comment
166	Output current detection signal retention time	0 to 10s,9999	0.1s	0.1	0.1		
>167	Output current detection operation selection	0,1	1	0	1	1	
168	Parameter for manufacturer setting. Do	---	1		8134		
169	Parameter for manufacturer setting. Do	---	1		1		
170	Watt-hour meter clear	0,10,9999	1	9999	9999		
171	Operation hour meter clear	0,9999	1	9999	9999		
178	STF terminal function selection	0 to 5,7,8,10,12,14,16,18,24,25,60,62,65 to 67,9999	1	60	60		
179	STR terminal function selection	0 to 5,7,8,10,12,14,16,18,24,25,61,62,65 to 67,9999	1	61	61		
180	RL terminal function selection	0 to 5,7,8,10,12,14,16,18,24,25,62,65 to 67,9999	1	0	0		
181	RM terminal function selection	0 to 5,7,8,10,12,14,16,18,24,25,62,65 to 67,9999	1	1	1		
182	RH terminal function selection	0 to 5,7,8,10,12,14,16,18,24,25,62,65 to 67,9999	1	2	2		
190	RUN terminal function selection	0,1,3,4,7,8,11 to 16,25,26,46,47,64,70,80,90,91,93,95,96,98,99,100,101,103,104,107,108,111 to 116,125,126,146,147,164,170,180,190,191,193,195,196,198,199,9999	1	0	0		
>192	A,B,C terminal function selection	0,1,3,4,7,8,11 to 16,25,26,46,47,64,70,80,90,91,95,96,98,99,100,101,103,104,107,108,111 to 116,125,126,146,147,164,170,180,190,191,195,196,198,199,9999	1	99	100	0	
232	Multi-speed setting (speed 8)	0 to 400Hz,9999	0.01Hz	9999	9999		
233	Multi-speed setting (speed 9)	0 to 400Hz,9999	0.01Hz	9999	9999		
234	Multi-speed setting (speed 10)	0 to 400Hz,9999	0.01Hz	9999	9999		
235	Multi-speed setting (speed 11)	0 to 400Hz,9999	0.01Hz	9999	9999		
236	Multi-speed setting (speed 12)	0 to 400Hz,9999	0.01Hz	9999	9999		
237	Multi-speed setting (speed 13)	0 to 400Hz,9999	0.01Hz	9999	9999		
238	Multi-speed setting (speed 14)	0 to 400Hz,9999	0.01Hz	9999	9999		
239	Multi-speed setting (speed 15)	0 to 400Hz,9999	0.01Hz	9999	9999		
240	Soft-PWM operation selection	0,1	1	1	1		

Selected St.: 00 FR-D720S-042-NA Date:5/7/2009

All Parameter List

FIT-36 base VFD rev.2\_19\_09

No.	Name	Setting Range	Unit	Initial	Current	Setting	Comment
241	Analog input display unit switchover	0,1	1	0	0		
244	Cooling fan operation selection	0,1	1	1	1		
245	Rated slip	0 to 50%,9999	0.01%	9999	9999		
246	Slip compensation time constant	0.01 to 10s	0.01s	0.5	0.5		
247	Constant-power range slip compensation selection	0,9999	1	9999	9999		
249	Earth (ground) fault detection at start	0,1	1	0	0		
250	Stop selection	0 to 100s,1000 to 1100s,8888,9999	0.1s	9999	9999		
251	Output phase loss protection selection	0,1	1	1	1		
255	Life alarm status display	(0 to 15)	1	0	0		
256	Inrush current limit circuit life display	(0 to 100%)	1%	100	100		
257	Control circuit capacitor life display	(0 to 100%)	1%	100	100		
258	Main circuit capacitor life display	(0 to 100%)	1%	100	100		
259	Main circuit capacitor life measuring	0,1 (2,3,8,9)	1	0	0		
>260	PWM frequency automatic switchover	0,1	1	0	1		
261	Power failure stop	0,1,2	1	0	0		
267	Terminal 4 input selection	0,1,2	1	0	0		
268	Monitor decimal digits selection	0,1,9999	1	9999	9999		
295	Magnitude of frequency change setting	0,0.01,0.10,1.00,10.00	0.01	0	0		
298	Frequency search gain	0 to 32767, 9999	1	9999	9999		
299	Rotation direction detection selection at restarting	0,1,9999	1	0	0		
338	Communication operation command source	0,1	1	0	0		
339	Communication speed command source	0,1,2	1	0	0		
340	Communication startup mode selection	0,1,10	1	0	0		
342	Communication EEPROM write selection	0,1	1	0	0		
343	Communication error count	-	1	0	0		
450	Second applied motor	0,1,9999	1	9999	9999		
495	Remote output selection	0,1,10,11	1	0	0		
496	Remote output data 1	0 to 4095	1	0	0		
502	Stop mode selection at communication error	0,1,2	1	0	0		
503	Maintenance timer	0 (1 to 9998)	1	0	0		
504	Maintenance timer alarm output set time	0 to 9998,9999	1	9999	9999	3	
549	Protocol selection	0,1	1	0	0		

Selected St.: 00 FR-D720S-042-NA Date:5/7/2009

All Parameter List

FIT-36 base VFD rev.2\_19\_09

No.	Name	Setting Range	Unit	Initial	Current	Setting	Comment
551	PU mode operation command source selection	2,4,9999	1	9999	9999		
555	Current average time	0.1 to 1s	0.1s	1	1		
556	Data output mask time	0 to 20s	0.1s	0	0		
557	Current average value monitor signal output reference current	0 to 500A	0.01A	4.2	4.2		
561	PTC thermistor protection level	0.5 to 30kohm,9999	0.01	9999	9999		
563	Energization time carrying-over times	(0 to 65535)	1	0	0		
564	Operating time carrying-over times	(0 to 65535)	1	0	0		
571	Holding time at a start	0 to 10s,9999	0.1s	9999	9999		
575	Output interruption detection time	0 to 3600s,9999	0.1s	1	1		
576	Output interruption detection level	0 to 400Hz	0.01Hz	0	0		
577	Output interruption cancel level	900 to 1100%	0.1%	1000	1000		
611	Acceleration time at a restart	0 to 3600s,9999	0.1s	9999	9999		
653	Speed smoothing control	0 to 200%	0.1%	0	0		
665	Regeneration avoidance frequency gain	0 to 200%	0.1%	100	100		
882	Regeneration avoidance operation selection	0,1,2	1	0	0		
883	Regeneration avoidance operation level	300 to 800V	0.1V	400	400		
885	Regeneration avoidance compensation frequency limit value	0 to 10Hz,9999	0.01Hz	6	6		
886	Regeneration avoidance voltage gain	0 to 200%	0.1%	100	100		
888	Free parameter 1	0 to 9999	1	9999	9999		
889	Free parameter 2	0 to 9999	1	9999	9999		
891	Cumulative power monitor digit shifted times	0 to 4,9999	1	9999	9999		
901	AM terminal calibration						
902	Terminal 2 frequency setting bias frequency	0 to 400Hz	0.01Hz	0	0		
(902)	Terminal 2 frequency setting bias	0 to 300%	0.1%	0	0		
>903	Terminal 2 frequency setting gain frequency	0 to 400Hz	0.01Hz	60	120	71	
(903)	Terminal 2 frequency setting gain	0 to 300%	0.1%	100	100		
904	Terminal 4 frequency setting bias frequency	0 to 400Hz	0.01Hz	0	0		
(904)	Terminal 4 frequency setting bias	0 to 300%	0.1%	20	20		
905	Terminal 4 frequency setting gain frequency	0 to 400Hz	0.01Hz	60	60		
(905)	Terminal 4 frequency setting gain	0 to 300%	0.1%	100	100		

No.	Name	Setting Range	Unit	Initial	Current	Setting	Comment
990	PU buzzer control	0,1	1	1	1		
991	PU contrast adjustment	0 to 63	1	58	58		

## 4.23 Parameter clear/ All parameter clear



### POINT

- Set "1" in *Pr.CL Parameter clear, ALLC all parameter clear* to initialize all parameters. (Parameters are not cleared when "1" is set in *Pr.77 Parameter write selection*.)
- Refer to the extended parameter list on *page 54* for parameters cleared with this operation.

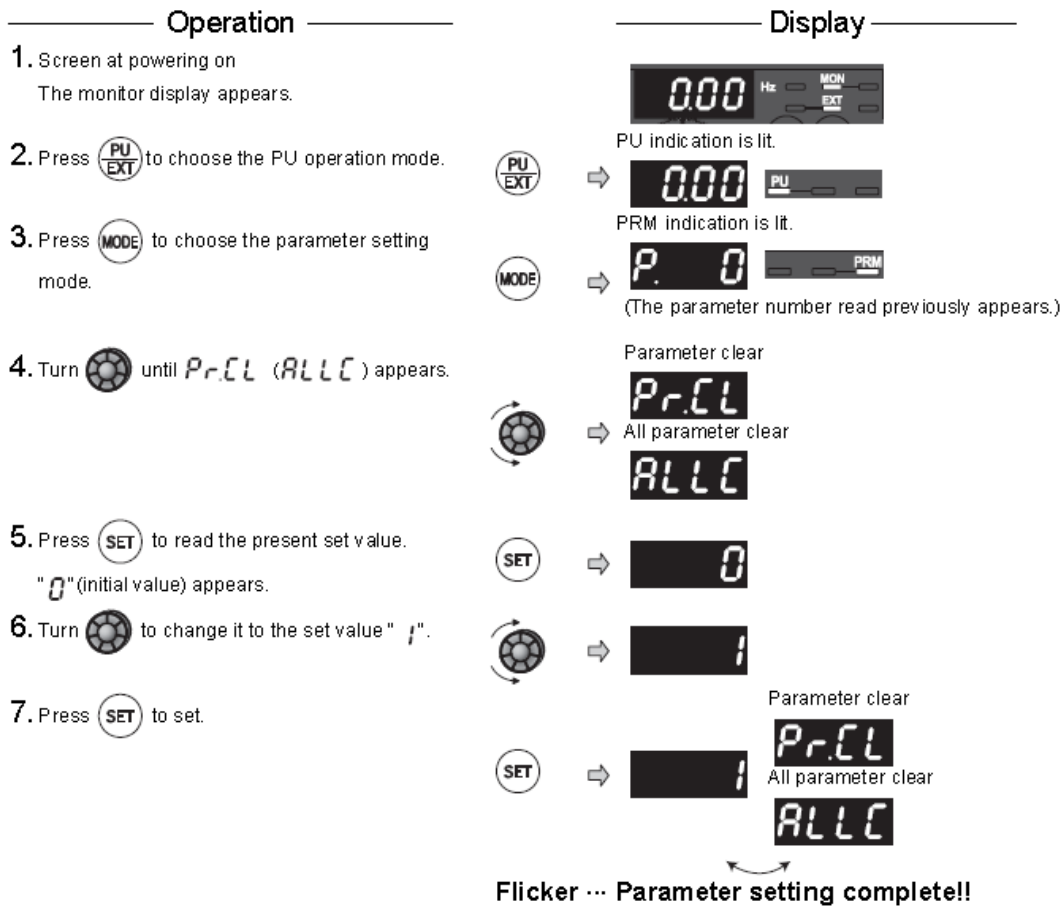

- Turn to read another parameter.
- Press to show the setting again.
- Press twice to show the next parameter.

Setting	Description
0	Not executed.
1	Set parameters back to the initial values. (Parameter clear sets back all parameters except <i>calibration parameters, terminal function selection parameters</i> to the initial values.) Refer to the <i>parameter list on page 54</i> for availability of parameter clear and all parameter clear.



## 4.24 Initial value change list

Displays and sets the parameters changed from the initial value.

Operation	Display
1. Screen at powering on The monitor display appears.	
2. Press  to choose the PU operation mode.	PU indication is lit. 
3. Press  to choose the parameter setting mode.	PRM indication is lit.  ⇒ (The parameter number read previously appears.)
4. Turn  until Pr.CH appears.	
5. Pressing  changes to the initial value change list screen.	
6. Turning  displays the parameter number changed.	
• Press  to read the present set value.	
Turn  and press  to change the setting (refer to step 6 and 7 on page 53)	
• Turn  to read another parameter.	
• The display returns to P. --- after all parameters are displayed.	
7. Pressing  in P. --- status returns to the parameter setting mode.	
• Turning  sets other parameters.	
• Pressing  displays the change list again.	

\* It may take several seconds for creating the initial value change list. "P. ---" flickers while creating the list.

Flicker Parameter setting complete!!



### NOTE

- Calibration parameters (C1 (Pr. 901) to C7 (Pr. 905)) are not displayed even when these are changed from the initial settings.
- Only simple mode parameter is displayed when simple mode is set (Pr. 160 = "9999" (initial value))
- Pr. 160 is displayed independently of whether the setting value is changed or not.
- When parameter setting is changed after creating the initial value change list, the setting will be reflected to the initial value change list next time.

When a fault occurs in the inverter, the inverter trips and the PU display automatically changes to any of the following fault or alarm indications.

If the fault does not correspond to any of the following faults or if you have any other problem, please contact your sales representative.

- Retention of fault output signal...When the magnetic contactor (MC) provided on the input side of the inverter is opened when a fault occurs, the inverter's control power will be lost and the fault output will not be held.
- Fault or alarm indication .....When a fault or alarm occurs, the operation panel display automatically switches to the fault or alarm indication.
- Resetting method .....When a fault occurs, the inverter output is kept stopped. Unless reset, therefore, the inverter cannot restart. (*Refer to page 246*)
- When any fault occurs, take the appropriate corrective action, then reset the inverter, and resume operation.  
Not doing so may lead to the inverter fault and damage.

Inverter fault or alarm indications are roughly divided as below.

- (1) Error message  
A message regarding operational fault and setting fault by the operation panel and parameter unit (FR-PU04 /FR-PU07) is displayed. The inverter does not trip.
- (2) Warnings  
The inverter does not trip even when a warning is displayed. However, failure to take appropriate measures will lead to a fault.
- (3) Alarm  
The inverter does not trip. You can also output an alarm signal by making parameter setting.
- (4) Fault  
When a fault occurs, the inverter trips and a fault signal is output.

## 5.1 Reset method of protective function

---

### (1) Resetting the inverter

The inverter can be reset by performing any of the following operations. Note that the internal thermal integrated value of the electronic thermal relay function and the number of retries are cleared (erased) by resetting the inverter.

Recover about 1s after reset is cancelled.

Operation 1: ..... Using the operation panel, press  to reset the inverter.

(This may only be performed when a fault occurs (*Refer to page 251* for fault.))

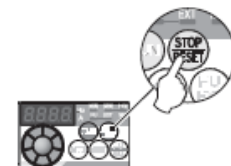

Operation 2: ..... Switch OFF the power once, then switch it ON again after the indicator of the operation panel turns OFF.

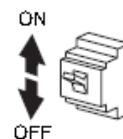

Operation 3: ..... Turn ON the reset signal (RES) for more than 0.1s. (If the RES signal is kept ON, "Err." appears (flickers) to indicate that the inverter is in a reset status.)

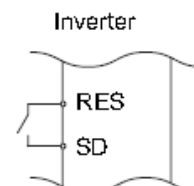

## 5.2 List of fault or alarm indications



Operation Panel Indication		Name	Refer to Page	Operation Panel Indication	Name	Refer to Page			
Error message	E---	E---	Faults history	242	Fault	EILF	E.ILF *	Input phase loss	254
	HOLd	HOLD	Operation panel lock	248		EOLT	E.OLT	Stall prevention	254
	LOCd	LOCd	Password locked	248		E. bE	E. BE	Brake transistor alarm detection	254
	Er1 to Er4	Er1 to 4	Parameter write error	248		E. GF	E.GF	Output side earth (ground) fault overcurrent at start	254
	Err.	Err.	Inverter reset	249		E. LF	E.LF	Output phase loss	254
Warnings	OL	OL	Stall prevention (overcurrent)	249		E.OHT	E.OHT	External thermal relay operation	252
	oL	oL	Stall prevention (overvoltage)	249		E.PTC	E.PTC*	PTC thermistor operation	252
	rb	RB	Regenerative brake prealarm	250		E. PE	E.PE	Parameter storage device fault	252
	rH	TH	Electronic thermal relay function prealarm	250		E.PUE	E.PUE	PU disconnection	252
	PS	PS	PU stop	250		E. RET	E.RET	Retry count excess	252
	MT	MT	Maintenance signal output	250		E. S / E.CPU	E.S / E.CPU	CPU fault	252
	UV	UV	Undervoltage	250		E.CDO	E.CDO*	Output current detection value exceeded	252
	SA	SA	Safety stop	251		E.IOH	E.IOH *	Inrush current limit circuit fault	252
Alarm	Fn	FN	Fan fault	251		E.AIE	E.AIE *	Analog input fault	252
Fault	E.OC1	E.OC1	Overcurrent trip during acceleration	251	E.SAF	E.SAF *	Safety circuit fault	252	
	E.OC2	E.OC2	Overcurrent trip during constant speed	251					
	E.OC3	E.OC3	Overcurrent trip during deceleration or stop	252					
	E.OV1	E.OV1	Regenerative overvoltage trip during acceleration	252					
	E.OV2	E.OV2	Regenerative overvoltage trip during constant speed	252					
	E.OV3	E.OV3	Regenerative overvoltage trip during deceleration or stop	252					
	E.THT	E.THT	Inverter overload trip (electronic thermal relay function)	253					
	E.THM	E.THM	Motor overload trip (electronic thermal relay function)	253					
	E.FIN	E.FIN	Fin overheat	253					

\* If a fault occurs when using with the FR-PU04, "Fault 14" is displayed on FR-PU04.

## 5.3 Causes and corrective actions

(1) Error message

A message regarding operational troubles is displayed. Output is not shutoff.

<b>Operation panel indication</b>	<b>HOLD</b>	<b>HOLD</b>
<b>Name</b>	Operation panel lock	
<b>Description</b>	Operation lock mode is set. Operation other than  is invalid. (Refer to page 237)	
<b>Check point</b>	—	
<b>Corrective action</b>	Press  for 2s to release lock.	

<b>Operation panel indication</b>	<b>LOCd</b>	<b>LOCd</b>
<b>Name</b>	Password locked	
<b>Description</b>	Password function is active. Display and setting of parameter is restricted.	
<b>Check point</b>	—	
<b>Corrective action</b>	Enter the password in Pr. 297 Password lock/unlock to unlock the password function before operating. (Refer to page 161).	

<b>Operation panel indication</b>	<b>Er1</b>	<b>Er1</b>
<b>Name</b>	Write disable error	
<b>Description</b>	<ol style="list-style-type: none"> <li>1. You attempted to make parameter setting when Pr. 77 Parameter write selection has been set to disable parameter write.</li> <li>2. Frequency jump setting range overlapped.</li> <li>3. The PU and inverter cannot make normal communication.</li> </ol>	
<b>Check point</b>	<ol style="list-style-type: none"> <li>1. Check the setting of Pr. 77 Parameter write selection. (Refer to page 159).</li> <li>2. Check the settings of Pr. 31 to Pr. 36 (frequency jump). (Refer to page 82)</li> <li>3. Check the connection of the PU and inverter.</li> </ol>	

<b>Operation panel indication</b>	<b>Er2</b>	<b>Er2</b>
<b>Name</b>	Write error during operation	
<b>Description</b>	When parameter write was performed during operation with a value other than "2" (writing is enabled independently of operation status in any operation mode) is set in Pr. 77 and the STF (STR) is ON.	
<b>Check point</b>	<ol style="list-style-type: none"> <li>1. Check the Pr. 77 setting. (Refer to page 159).</li> <li>2. Check that the inverter is not operating.</li> </ol>	
<b>Corrective action</b>	<ol style="list-style-type: none"> <li>1. Set "2" in Pr. 77.</li> <li>2. After stopping operation, make parameter setting.</li> </ol>	

<b>Operation panel indication</b>	<b>Er3</b>	<b>Er3</b>
<b>Name</b>	Calibration error	
<b>Description</b>	Analog input bias and gain calibration values are too close.	
<b>Check point</b>	Check the settings of C3, C4, C6 and C7 (calibration functions). (Refer to page 151).	

<b>Operation panel indication</b>	<b>Er4</b>	<b>Er4</b>
<b>Name</b>	Mode designation error	
<b>Description</b>	You attempted to make parameter setting in the NET operation mode when Pr. 77 is not 2.	
<b>Check point</b>	<ol style="list-style-type: none"> <li>1. Check that operation mode is PU operation mode.</li> <li>2. Check the Pr. 77 setting. (Refer to page 159).</li> </ol>	
<b>Corrective action</b>	<ol style="list-style-type: none"> <li>1. After setting the operation mode to the "PU operation mode", make parameter setting. (Refer to page 163)</li> <li>2. After setting "2" in Pr. 77, make parameter setting.</li> </ol>	





<b>Operation panel indication</b>	Err.	Err.
<b>Name</b>	Inverter reset	
<b>Description</b>	<ul style="list-style-type: none"> <li>▪ Executing reset using RES signal, or reset command from communication or PU</li> <li>▪ Displays at powering OFF.</li> </ul>	
<b>Corrective action</b>	<ul style="list-style-type: none"> <li>▪ Turn OFF the reset command</li> </ul>	

(2) Warnings

When a warning occurs, the output is not shut off.

<b>Operation panel indication</b>	OL	OL	FR-PU04 FR-PU07	OL
<b>Name</b>	Stall prevention (overcurrent)			
<b>Description</b>	During acceleration	When the output current of the inverter exceeds the stall prevention operation level ( <i>Pr. 22 Stall prevention operation level</i> , etc.), this function stops the increase in frequency until the overload current decreases to prevent the inverter from resulting in overcurrent trip. When the overload current has reduced below stall prevention operation level, this function increases the frequency again.		
	During constant-speed operation	When the output current of the inverter exceeds the stall prevention operation level ( <i>Pr. 22 Stall prevention operation level</i> , etc.), this function reduces frequency until the overload current decreases to prevent the inverter from resulting in overcurrent trip. When the overload current has reduced below stall prevention operation level, this function increases the frequency up to the set value.		
	During deceleration	When the output current of the inverter exceeds the stall prevention operation level ( <i>Pr. 22 Stall prevention operation level</i> , etc.), this function stops the decrease in frequency until the overload current decreases to prevent the inverter from resulting in overcurrent trip. When the overload current has decreased below stall prevention operation level, this function decreases the frequency again.		
<b>Check point</b>	<ol style="list-style-type: none"> <li>1. Check that the <i>Pr. 0 Torque boost</i> setting is not too large.</li> <li>2. Check that the <i>Pr. 7 Acceleration time</i> and <i>Pr. 8 Deceleration time</i> settings are not too small.</li> <li>3. Check that the load is not too heavy.</li> <li>4. Are there any failure in peripheral devices?</li> <li>5. Check that the <i>Pr. 13 Starting frequency</i> is not too large.</li> <li>6. Check that the <i>Pr. 22 Stall prevention operation level</i> is appropriate</li> </ol>			
<b>Corrective action</b>	<ol style="list-style-type: none"> <li>1. Increase or decrease the <i>Pr. 0 Torque boost</i> setting by 1% and check the motor status. (<i>Refer to page 71</i>)</li> <li>2. Set a larger value in <i>Pr. 7 Acceleration time</i> and <i>Pr. 8 Deceleration time</i>. (<i>Refer to page 94</i>)</li> <li>3. Reduce the load weight.</li> <li>4. Try General-purpose magnetic flux vector control.</li> <li>5. Change the <i>Pr. 14 Load pattern selection</i> setting.</li> <li>6. Set stall prevention operation current in <i>Pr. 22 Stall prevention operation level</i>. (The initial value is 150%.) The acceleration/deceleration time may change. Increase the stall prevention operation level with <i>Pr. 22 Stall prevention operation level</i>, or disable stall prevention with <i>Pr. 156 Stall prevention operation selection</i>. (Operation at OL occurrence can be selected using <i>Pr. 156</i>.)</li> </ol>			

<b>Operation panel indication</b>	oL	oL	FR-PU04 FR-PU07	oL
<b>Name</b>	Stall prevention (overvoltage)			
<b>Description</b>	During deceleration	<ul style="list-style-type: none"> <li>▪ If the regenerative energy of the motor becomes excessive to exceed the regenerative energy consumption capability, this function stops the decrease in frequency to prevent overvoltage trip. As soon as the regenerative energy has reduced, deceleration resumes.</li> <li>▪ If the regenerative energy of the motor becomes excessive when regeneration avoidance function is selected (<i>Pr. 882 = 1</i>), this function increases the speed to prevent overvoltage trip. (<i>Refer to page 224</i>).</li> </ul>		
		<ul style="list-style-type: none"> <li>▪ Check for sudden speed reduction.</li> <li>▪ Check that regeneration avoidance function (<i>Pr. 882, Pr. 883, Pr. 885, Pr. 886</i>) is used. (<i>Refer to page 224</i>).</li> </ul>		
<b>Check point</b>				
<b>Corrective action</b>	The deceleration time may change. Increase the deceleration time using <i>Pr. 8 Deceleration time</i> .			

Operation panel indication	PS		FR-PU04 FR-PU07	PS
Name	PU stop			
Description	Stop with  of the PU is set in <i>Pr. 75 Reset selection/disconnected PU detection/PU stop selection</i> . (For <i>Pr. 75</i> refer to <i>page 156</i> .)			
Check point	Check for a stop made by pressing  of the operation panel.			
Corrective action	Turn the start signal OFF and release with  .			

Operation panel indication	RB		FR-PU04 FR-PU07	RB
Name	Regenerative brake prealarm			
Description	Appears if the regenerative brake duty reaches or exceeds 85% of the <i>Pr. 70 Special regenerative brake duty</i> value. When the setting of <i>Pr. 70 Special regenerative brake duty</i> is the initial value ( <i>Pr. 70</i> = "0"), this warning does not occur. If the regenerative brake duty reaches 100%, a regenerative overvoltage (E. OV_) occurs. The RBP signal can be simultaneously output with the [RB] display. For the terminal used for the RBP signal output, assign the function by setting "7 (positive logic) or 107 (negative logic)" in <i>Pr. 190</i> or <i>Pr. 192 (output terminal function selection)</i> . (Refer to <i>page 117</i> ).			
Check point	1. Check that the brake resistor duty is not high. 2. Check that the <i>Pr. 30 Regenerative function selection</i> and <i>Pr. 70 Special regenerative brake duty</i> settings are correct.			
Corrective action	1. Increase the deceleration time. 2. Check that the <i>Pr. 30 Regenerative function selection</i> and <i>Pr. 70 Special regenerative brake duty</i> settings.			

Operation panel indication	TH		FR-PU04 FR-PU07	TH
Name	Electronic thermal relay function prealarm			
Description	Appears if the cumulative value of the <i>Pr. 9 Electronic thermal O/L relay</i> reaches or exceeds 85% of the preset level. If it reaches 100% of the <i>Pr. 9 Electronic thermal O/L relay</i> setting, a motor overload trip (E. THM) occurs. The THP signal can be simultaneously output with the [TH] display. For the terminal used for THP signal output, assign the function by setting "8 (positive logic) or 108 (negative logic)" in <i>Pr. 190</i> or <i>Pr. 192 (output terminal function selection)</i> . (Refer to <i>page 117</i> ).			
Check point	1. Check for large load or sudden acceleration. 2. Is the <i>Pr. 9 Electronic thermal O/L relay</i> setting is appropriate? (Refer to <i>page 98</i> )			
Corrective action	1. Reduce the load and frequency of operation. 2. Set an appropriate value in <i>Pr. 9 Electronic thermal O/L relay</i> . (Refer to <i>page 98</i> )			

Operation panel indication	MT		FR-PU04 FR-PU07	— MT
Name	Maintenance signal output			
Description	Indicates that the cumulative energization time of the inverter has reached a given time. When the setting of <i>Pr. 504 Maintenance timer alarm output set time</i> is the initial value ( <i>Pr. 504</i> = "9999"), this warning does not occur.			
Check point	The <i>Pr. 503 Maintenance timer</i> setting is larger than the <i>Pr. 504 Maintenance timer alarm output set time</i> setting. (Refer to <i>page 231</i> ).			
Corrective action	Setting "0" in <i>Pr. 503 Maintenance timer</i> erases the signal.			

Operation panel indication	UV		FR-PU04 FR-PU07	—
Name	Undervoltage			
Description	If the power supply voltage of the inverter decreases, the control circuit will not perform normal functions. In addition, the motor torque will be insufficient and/or heat generation will increase. To prevent this, if the power supply voltage decreases below about 115VAC (about 230VAC for 400V class, about 58VAC for 100V class), this function stops the inverter output and displays UV. An alarm is reset when the voltage returns to normal.			
Check point	Check that the power supply voltage is normal.			
Corrective action	Check the power supply system equipment such as power supply.			

Operation panel indication	SA	SA	FR-PU04 FR-PU07	—
Name	Safety stop			
Description	Appears when safety stop function is activated (during output shutoff).			
Check point	If the indication appears when safety stop function is not used, check that shorting wires between S1 and SC, S2 and SC are connected.			
Corrective action	If the indication appears when safety stop function is not used, short between S1 and SC, S2 and SC with shorting wires.			

### (3) Alarm

When an alarm occurs, the output is not shut off. You can also output an alarm signal by making parameter setting. (Set "98" in Pr. 190 or Pr. 192 (output terminal function selection). Refer to page 117).

Operation panel indication	FN	F <sub>n</sub>	FR-PU04 FR-PU07	FN
Name	Fan fault			
Description	For the inverter that contains a cooling fan, F <sub>n</sub> appears on the operation panel when the cooling fan stops due to an alarm or different operation from the setting of Pr. 244 Cooling fan operation selection.			
Check point	Check the cooling fan for an alarm.			
Corrective action	Check for fan alarm. Please contact your sales representative.			

### (4) Fault

When a fault occurs, the inverter trips and a fault signal is output.

Operation panel indication	E.OC1	E.OC 1	FR-PU04 FR-PU07	OC During Acc
Name	Overcurrent trip during acceleration			
Description	When the inverter output current reaches or exceeds approximately 200% of the rated current during acceleration, the protective circuit is activated and the inverter trips.			
Check point	<ol style="list-style-type: none"> <li>1. Check for sudden acceleration.</li> <li>2. Check that the downward acceleration time is not long in vertical lift application.</li> <li>3. Check for output short-circuit/ground fault.</li> <li>4. Check that the Pr. 3 Base frequency setting is not 60Hz when the motor rated frequency is 50Hz.</li> <li>5. Check that stall prevention operation is appropriate.</li> <li>6. Check that regeneration is not performed frequently. (Check that the output voltage becomes larger than the V/F reference value at regeneration and overcurrent occurs due to increase in motor current.)</li> </ol>			
Corrective action	<ol style="list-style-type: none"> <li>1. Increase the acceleration time. (Shorten the downward acceleration time in vertical lift application.)</li> <li>2. When "E.OC1" is always lit at starting, disconnect the motor once and start the inverter. If "E.OC1" is still lit, contact your sales representative.</li> <li>3. Check the wiring to make sure that output short circuit/ground fault does not occur.</li> <li>4. Set 50Hz in Pr. 3 Base frequency. (Refer to page 83)</li> <li>5. Perform stall prevention operation appropriately. (Refer to page 77).</li> <li>6. Set base voltage (rated voltage of the motor, etc.) in Pr. 19 Base frequency voltage. (Refer to page 83)</li> </ol>			

Operation panel indication	E.OC2	E.OC2	FR-PU04 FR-PU07	Stedy Spd OC
Name	Overcurrent trip during constant speed			
Description	When the inverter output current reaches or exceeds approximately 200% of the rated current during constant speed operation, the protective circuit is activated and the inverter trips.			
Check point	<ol style="list-style-type: none"> <li>1. Check for sudden load change.</li> <li>2. Check for output short-circuit/ground fault.</li> <li>3. Check that stall prevention operation is appropriate.</li> </ol>			
Corrective action	<ol style="list-style-type: none"> <li>1. Keep load stable.</li> <li>2. Check the wiring to make sure that output short circuit/ground fault does not occur.</li> <li>3. Perform stall prevention operation appropriately. (Refer to page 77).</li> </ol>			

<b>Operation panel indication</b>	E.OC3	<b>E.OC3</b>	FR-PU04 FR-PU07	<b>OC During Dec</b>
<b>Name</b>	Overcurrent trip during deceleration or stop			
<b>Description</b>	When the inverter output current reaches or exceeds approximately 200% of the rated inverter current during deceleration (other than acceleration or constant speed), the protective circuit is activated and the inverter trips.			
<b>Check point</b>	<ol style="list-style-type: none"> <li>1. Check for sudden speed reduction.</li> <li>2. Check for output short-circuit/ground fault.</li> <li>3. Check for too fast operation of the motor's mechanical brake.</li> <li>4. Check that stall prevention operation is appropriate.</li> </ol>			
<b>Corrective action</b>	<ol style="list-style-type: none"> <li>1. Increase the deceleration time.</li> <li>2. Check the wiring to make sure that output short circuit/ground fault does not occur.</li> <li>3. Check the mechanical brake operation.</li> <li>4. Perform stall prevention operation appropriately. (Refer to page 77).</li> </ol>			

<b>Operation panel indication</b>	E.OV1	<b>E.OV1</b>	FR-PU04 FR-PU07	<b>OV During Acc</b>
<b>Name</b>	Regenerative overvoltage trip during acceleration			
<b>Description</b>	If regenerative energy causes the inverter's internal main circuit DC voltage to reach or exceed the specified value, the protective circuit is activated and the inverter trips. The circuit may also be activated by a surge voltage produced in the power supply system.			
<b>Check point</b>	<ol style="list-style-type: none"> <li>1. Check for too slow acceleration. (e.g. during downward acceleration in vertical lift load)</li> <li>2. Check that the setting of <i>Pr. 22 Stall prevention operation level</i> is not too small.</li> </ol>			
<b>Corrective action</b>	<ol style="list-style-type: none"> <li>1. <ul style="list-style-type: none"> <li>▪ Decrease the acceleration time.</li> <li>▪ Use regeneration avoidance function (<i>Pr. 882, Pr. 883, Pr. 885, Pr. 886</i>). (Refer to page 224).</li> </ul> </li> <li>2. Set the <i>Pr.22 Stall prevention operation level</i> correctly.</li> </ol>			

<b>Operation panel indication</b>	E.OV2	<b>E.OV2</b>	FR-PU04 FR-PU07	<b>Stedy Spd OV</b>
<b>Name</b>	Regenerative overvoltage trip during constant speed			
<b>Description</b>	If regenerative energy causes the inverter's internal main circuit DC voltage to reach or exceed the specified value, the protective circuit is activated to stop the inverter output. The circuit may also be activated by a surge voltage produced in the power supply system.			
<b>Check point</b>	<ol style="list-style-type: none"> <li>1. Check for sudden load change.</li> <li>2. Check that the setting of <i>Pr. 22 Stall prevention operation level</i> is not too small.</li> </ol>			
<b>Corrective action</b>	<ol style="list-style-type: none"> <li>1. <ul style="list-style-type: none"> <li>▪ Keep load stable.</li> <li>▪ Use regeneration avoidance function (<i>Pr. 882, Pr. 883, Pr. 885, Pr. 886</i>). (Refer to page 224).</li> <li>▪ Use the brake resistor, brake unit or power regeneration common converter (FR-CV) as required.</li> </ul> </li> <li>2. Set the <i>Pr.22 Stall prevention operation level</i> correctly.</li> </ol>			

<b>Operation panel indication</b>	E.OV3	<b>E.OV3</b>	FR-PU04 FR-PU07	<b>OV During Dec</b>
<b>Name</b>	Regenerative overvoltage trip during deceleration or stop			
<b>Description</b>	If regenerative energy causes the inverter's internal main circuit DC voltage to reach or exceed the specified value, the protective circuit is activated to stop the inverter output. The circuit may also be activated by a surge voltage produced in the power supply system.			
<b>Check point</b>	Check for sudden speed reduction.			
<b>Corrective action</b>	<ul style="list-style-type: none"> <li>▪ Increase the deceleration time. (Set the deceleration time which matches the moment of inertia of the load)</li> <li>▪ Make the brake cycle longer.</li> <li>▪ Use regeneration avoidance function (<i>Pr. 882, Pr. 883, Pr. 885, Pr. 886</i>). (Refer to page 224).</li> <li>▪ Use the brake resistor, brake unit or power regeneration common converter (FR-CV) as required.</li> </ul>			

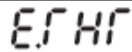

<b>Operation panel indication</b>	E.THT		FR-PU04 FR-PU07	<b>Inv. Overload</b>
<b>Name</b>	Inverter overload trip (electronic thermal relay function)			
<b>Description</b>	If the temperature of the output transistor element exceeds the protection level under the condition that a current not less than the rated inverter current flows and overcurrent trip does not occur (200% or less), the electronic thermal relay activates to stop the inverter output. (Overload capacity 150% 60s, 200% 0.5s)			
<b>Check point</b>	<ol style="list-style-type: none"> <li>1. Check that acceleration/deceleration time is not too short.</li> <li>2. Check that torque boost setting is not too large (small).</li> <li>3. Check that load pattern selection setting is appropriate for the load pattern of the using machine.</li> <li>4. Check the motor for use under overload.</li> <li>5. Check for too high surrounding air temperature.</li> </ol>			
<b>Corrective action</b>	<ol style="list-style-type: none"> <li>1. Increase acceleration/deceleration time.</li> <li>2. Adjust the torque boost setting.</li> <li>3. Set the load pattern selection setting according to the load pattern of the using machine.</li> <li>4. Reduce the load weight.</li> <li>5. Set the surrounding air temperature to within the specifications.</li> </ol>			

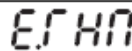
<b>Operation panel indication</b>	E.THM		FR-PU04 FR-PU07	<b>Motor Ovrload</b>
<b>Name</b>	Motor overload trip (electronic thermal relay function) *1			
<b>Description</b>	The electronic thermal relay function in the inverter detects motor overheat due to overload or reduced cooling capability during constant-speed operation, and pre-alarm (TH display) is output when the integrated value reaches 85% of the <i>Pr. 9 Electronic thermal O/L relay</i> setting, and the protection circuit is activated to stop the inverter output when the integrated value reaches the specified value. When running a special motor such as a multi-pole motor or multiple motors, provide a thermal relay on the inverter output side since such motor(s) cannot be protected by the electronic thermal relay function.			
<b>Check point</b>	<ol style="list-style-type: none"> <li>1. Check the motor for use under overload.</li> <li>2. Check that the setting of <i>Pr. 71 Applied motor</i> for motor selection is correct. (Refer to page 101).</li> <li>3. Check that stall prevention operation setting is correct.</li> </ol>			
<b>Corrective action</b>	<ol style="list-style-type: none"> <li>1. Reduce the load weight.</li> <li>2. For a constant-torque motor, set the constant-torque motor in <i>Pr. 71 Applied motor</i>.</li> <li>3. Check that stall prevention operation setting is correct. (Refer to page 77).</li> </ol>			

\*1 Resetting the inverter initializes the internal thermal integrated data of the electronic thermal relay function.

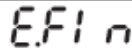
<b>Operation panel indication</b>	E.FIN		FR-PU04 FR-PU07	<b>H/Sink O/Temp</b>
<b>Name</b>	Fin overheat			
<b>Description</b>	<p>If the heatsink overheats, the temperature sensor is actuated and the inverter trips.</p> <p>The FIN signal can be output when the temperature becomes approximately 85% of the heatsink overheat protection operation temperature.</p> <p>For the terminal used for the FIN signal output, assign the function by setting "26 (positive logic) or 126 (negative logic)" in <i>Pr. 190 or Pr. 192 (output terminal function selection)</i>. (Refer to page 117).</p>			
<b>Check point</b>	<ol style="list-style-type: none"> <li>1. Check for too high surrounding air temperature.</li> <li>2. Check for heatsink clogging.</li> <li>3. Check that the cooling fan is not stopped (Check that <math>F_n</math> is not displayed on the operation panel).</li> </ol>			
<b>Corrective action</b>	<ol style="list-style-type: none"> <li>1. Set the surrounding air temperature to within the specifications.</li> <li>2. Clean the heatsink.</li> <li>3. Replace the cooling fan.</li> </ol>			

<b>Operation panel indication</b>	E.ILF	<b>E.ILF</b>	FR-PU04 FR-PU07	<b>Fault 14</b> <b>Input phase loss</b>
<b>Name</b>	Input phase loss *			
<b>Description</b>	Inverter trips when function valid setting (=1) is selected in <i>Pr. 872 Input phase loss protection selection</i> and one phase of the three phase power input is lost. (Refer to page 144). It may function if phase-to-phase voltage of the three-phase power input becomes largely unbalanced. When the setting of <i>Pr. 872 Input phase loss protection selection</i> is the initial value ( <i>Pr. 872</i> = "0"), this warning does not occur.			
<b>Check point</b>	<ul style="list-style-type: none"> <li>• Check for a break in the cable for the three-phase power supply input.</li> <li>• Check that phase-to-phase voltage of the three-phase power input is not largely unbalanced.</li> </ul>			
<b>Corrective action</b>	<ul style="list-style-type: none"> <li>• Wire the cables properly.</li> <li>• Repair a break portion in the cable.</li> <li>• Check the <i>Pr. 872 Input phase loss protection selection</i> setting.</li> <li>• Set <i>Pr. 872</i> = "0" (without input phase loss protection) when three-phase input voltage is largely unbalanced.</li> </ul>			

\* Available only for three-phase power input specification model.

<b>Operation panel indication</b>	E.OLT	<b>E.OLF</b>	FR-PU04 FR-PU07	<b>Still Prev STP (OL shown during stall prevention operation)</b>
<b>Name</b>	Stall prevention			
<b>Description</b>	If the output frequency has fallen to 1Hz by stall prevention operation and remains for 3s, a fault (E.OLT) appears and the inverter trips. OL appears while stall prevention is being activated. E.OLT may not occur if stall prevention (OL) is activated during output phase loss.			
<b>Check point</b>	<ul style="list-style-type: none"> <li>• Check the motor for use under overload. (Refer to page 78).</li> </ul>			
<b>Corrective action</b>	<ul style="list-style-type: none"> <li>• Reduce the load weight. (Check the <i>Pr. 22 Stall prevention operation level</i> setting.)</li> </ul>			

<b>Operation panel indication</b>	E.BE	<b>E. bE</b>	FR-PU04 FR-PU07	<b>Br. Cct. Fault</b>
<b>Name</b>	Brake transistor alarm detection			
<b>Description</b>	When a brake transistor alarm has occurred due to the large regenerative energy from the motor etc., the brake transistor alarm is detected and the inverter trips. <u>In this case, the inverter must be powered off immediately.</u>			
<b>Check point</b>	<ul style="list-style-type: none"> <li>• Reduce the load inertia.</li> <li>• Check that the frequency of using the brake is proper.</li> <li>• Check that the brake resistor selected is correct.</li> </ul>			
<b>Corrective action</b>	Replace the inverter.			

<b>Operation panel indication</b>	E.GF	<b>E. GF</b>	FR-PU04 FR-PU07	<b>Ground Fault</b>
<b>Name</b>	Output side earth (ground) fault overcurrent at start			
<b>Description</b>	The inverter trips if an earth (ground) fault overcurrent flows at start due to an earth (ground) fault that occurred on the inverter's output side (load side). Whether this protective function is used or not is set with <i>Pr. 249 Earth (ground) fault detection at start</i> . When the setting of <i>Pr. 249 Earth (ground) fault detection at start</i> is the initial value ( <i>Pr. 249</i> = "0"), this warning does not occur.			
<b>Check point</b>	Check for a ground fault in the motor and connection cable.			
<b>Corrective action</b>	Remedy the ground fault portion.			

<b>Operation panel indication</b>	E.LF	<b>E. LF</b>	FR-PU04 FR-PU07	<b>E.LF</b>
<b>Name</b>	Output phase loss			
<b>Description</b>	If one of the three phases (U, V, W) on the inverter's output side (load side) is lost during inverter operation (except during DC injection brake operation and when output frequency is under 1Hz), inverter stops the output. Whether the protective function is used or not is set with <i>Pr. 251 Output phase loss protection selection</i> .			
<b>Check point</b>	<ul style="list-style-type: none"> <li>• Check the wiring. (Check that the motor is normal.)</li> <li>• Check that the capacity of the motor used is not smaller than that of the inverter.</li> </ul>			
<b>Corrective action</b>	<ul style="list-style-type: none"> <li>• Wire the cables properly.</li> <li>• Check the <i>Pr. 251 Output phase loss protection selection</i> setting.</li> </ul>			

<b>Operation panel indication</b>	E.OHT	<i>E.OHT</i>	FR-PU04 FR-PU07	<b>OH Fault</b>
<b>Name</b>	External thermal relay operation			
<b>Description</b>	If the external thermal relay provided for motor overheat protection or the internally mounted temperature relay in the motor, etc. switches on (contacts open), the inverter output is stopped. Functions when "7" (OH signal) is set in any of <i>Pr. 178 to Pr. 182 (input terminal function selection)</i> . This protective function does not function in the initial status (OH signal is not assigned).			
<b>Check point</b>	<ul style="list-style-type: none"> <li>Check for motor overheating.</li> <li>Check that the value of 7 (OH signal) is set correctly in any of <i>Pr. 178 to Pr. 182 (input terminal function selection)</i>.</li> </ul>			
<b>Corrective action</b>	<ul style="list-style-type: none"> <li>Reduce the load and frequency of operation.</li> <li>Even if the relay contacts are reset automatically, the inverter will not restart unless it is reset.</li> </ul>			

<b>Operation panel indication</b>	E.PTC	<i>E.PTC</i>	FR-PU04 FR-PU07	<b>Fault 14</b> <b>PTC activated</b>
<b>Name</b>	PTC thermistor operation			
<b>Description</b>	Inverter trips when resistance of PTC thermistor connected between terminal 2 and terminal 10 is more than the value set in <i>Pr. 561 PTC thermistor protection level</i> . This protective function does not function when <i>Pr. 561</i> setting is initial value ( <i>Pr. 561</i> = "9999").			
<b>Check point</b>	<ul style="list-style-type: none"> <li>Check the connection of the PTC thermistor.</li> <li>Check the <i>Pr. 561 PTC thermistor protection level</i> setting.</li> <li>Check the motor for operation under overload.</li> </ul>			
<b>Corrective action</b>	Reduce the load weight.			

<b>Operation panel indication</b>	E.PE	<i>E. PE</i>	FR-PU04 FR-PU07	<b>Corrupt Memry</b>
<b>Name</b>	Parameter storage device fault (control circuit board)			
<b>Description</b>	Appears when a fault occurred in the stored parameters. (EEPROM fault)			
<b>Check point</b>	Check for too many number of parameter write times.			
<b>Corrective action</b>	Please contact your sales representative. When performing parameter write frequently for communication purposes, set "1" in <i>Pr. 342</i> to enable RAM write. Note that powering off returns the inverter to the status before RAM write.			

<b>Operation panel indication</b>	E.PUE	<i>E.PUE</i>	FR-PU04 FR-PU07	<b>PU Leave Out</b>
<b>Name</b>	PU disconnection			
<b>Description</b>	<ul style="list-style-type: none"> <li>This function stops the inverter output if communication between the inverter and PU is suspended, e.g. the parameter unit (FR-PU04/FR-PU07) is disconnected, when "2", "3", "16" or "17" was set in <i>Pr. 75 Reset selection/disconnected PU detection/PU stop selection</i>.</li> <li>This function stops the inverter output when communication errors occurred consecutively for more than permissible number of retries when a value other than "9999" is set in <i>Pr. 121 Number of PU communication retries</i> during the RS-485 communication with the PU connector (use <i>Pr. 502 Stop mode selection at communication error</i> to change).</li> <li>This function also stops the inverter output if communication is broken within the period of time set in <i>Pr. 122 PU communication check time interval</i> during the RS-485 communication with the PU connector.</li> </ul>			
<b>Check point</b>	<ul style="list-style-type: none"> <li>Check that the parameter unit cable is connected properly.</li> <li>Check the <i>Pr. 75</i> setting.</li> <li>Check that RS-485 communication data is correct. And check that the settings of communication parameter at inverter match settings of the computer.</li> <li>Check that data is transmitted from the computer within a time set in <i>Pr. 122 PU communication check time interval</i>.</li> </ul>			
<b>Corrective action</b>	Connect the parameter unit cable securely. Check the communication data and communication settings. Increase the <i>Pr. 122 PU communication check time interval</i> setting. Or set "9999" (no communication check).			

<b>Operation panel indication</b>	E.RET	<i>E.RET</i>	FR-PU04 FR-PU07	<b>Retry No Over</b>
<b>Name</b>	Retry count excess			
<b>Description</b>	If operation cannot be resumed properly within the number of retries set, this function trips the inverter. Functions only when <i>Pr. 67 Number of retries at fault occurrence</i> is set. When the initial value ( <i>Pr. 67</i> = "0") is set, this protective function does not function.			
<b>Check point</b>	Find the cause of fault occurrence.			
<b>Corrective action</b>	Eliminate the cause of the error preceding this error indication.			

Operation panel indication	E.5	E.5	FR-PU04	Fault 5
	E.CPU	E.CPU	FR-PU07	CPU Fault
Name	CPU fault			
Description	Stops the inverter output if the communication fault of the built-in CPU occurs.			
Check point	Check for devices producing excess electrical noises around the inverter.			
Corrective action	<ul style="list-style-type: none"> <li>Take measures against noises if there are devices producing excess electrical noises around the inverter.</li> <li>Please contact your sales representative.</li> </ul>			

Operation panel indication	E.CDO	E.CDO	FR-PU04	Fault 14
			FR-PU07	OC detect level
Name	Output current detection value exceeded			
Description	This function is activated when the output current exceeds the <i>Pr. 150 Output current detection level</i> setting.			
Check point	Check the settings of <i>Pr. 150 Output current detection level</i> , <i>Pr. 151 Output current detection signal delay time</i> , <i>Pr. 166 Output current detection signal retention time</i> , <i>Pr. 167 Output current detection operation selection</i> . (Refer to page 122)			

Operation panel indication	E.IOH	E.IOH	FR-PU04	Fault 14
			FR-PU07	Inrush overheat
Name	Inrush current limit circuit fault			
Description	This function is activated when the resistor of the inrush current limit circuit overheats. The inrush current limit circuit fault			
Check point	Check that frequent power ON/OFF is not repeated.			
Corrective action	Configure a circuit where frequent power ON/OFF is not repeated. If the problem still persists after taking the above measure, please contact your sales representative.			

Operation panel indication	E.AIE	E.AIE	FR-PU04	Fault 14
			FR-PU07	Analog in error
Name	Analog input fault			
Description	Appears if voltage(current) is input to terminal 4 when the setting in <i>Pr.267 Terminal 4 input selection</i> and the setting of voltage/current input switch are different.			
Check point	Check the setting of <i>Pr. 267 Terminal 4 input selection</i> and voltage/current input switch. (Refer to page 148).			
Corrective action	Either give a frequency command by current input or set <i>Pr. 267 Terminal 4 input selection</i> , and voltage/current input switch to voltage input.			

Operation panel indication	E.SAF	E.SAF	FR-PU04	Fault 14
			FR-PU07	Fault E.SAF
Name	Safety circuit fault			
Description	Appears when safety circuit is malfunctioning. Appears when one of the lines between S1 and SC, or between S2 and SC is opened.			
Check point	<ul style="list-style-type: none"> <li>If the indication appears when safety stop function is not used, check that shorting wires between S1 and SC, S2 and SC are connected.</li> <li>Check that the safety relay module is properly connected.</li> </ul>			
Corrective action	If the indication appears when safety stop function is not used, short between S1 and SC, S2 and SC with shorting wires.			



## NOTE

- If protective functions of E.ILF, E.AIE, E.IOH, E.PTC, E.CDO, E.SAF are activated when using the FR-PU04, "Fault 14" is displayed.
- Also when the faults history is checked on the FR-PU04, the display is "E.14".
- If faults other than the above appear, contact your sales representative.

# PITNEY BOWES

There are the following correspondences between the actual alphanumeric characters and the digital characters displayed on the operation panel:

Actual	Digital
0	0
1	1
2	2
3	3
4	4
5	5
6	6
7	7
8	8
9	9

Actual	Digital
A	A
B	b
C	C
D	d
E	E
F	F
G	G
H	H
I	I
J	J
L	L

Actual	Digital
M	m
N	n
O	O
o	o
P	P
S	S
T	T
U	U
V	V
r	r
-	-



## 5.5 Check first when you have some troubles



**POINT**

- If the cause is still unknown after every check, it is recommended to initialize the parameters (initial value) then set the required parameter values and check again.

### 5.5.1 Motor does not start

Check points	Possible Cause	Countermeasures	Refer to page
<b>Main Circuit</b>	Appropriate power supply voltage is not applied. (Operation panel display is not provided.)	Power on moulded case circuit breaker (MCCB), an earth leakage circuit breaker (ELB), or a magnetic contactor (MC). Check for the decreased input voltage, input phase loss, and wiring.	—
	Motor is not connected properly.	Check the wiring between the inverter and the motor.	15
	The jumper across P/+ to P1 is disconnected.	Securely fit a jumper across P/+ to P1. When using a DC reactor (FR-HEL), remove the jumper across P/+ to P1, and then connect the DC reactor.	34
<b>Input Signal</b>	Start signal is not input.	Check the start command source, and input a start signal. PU operation mode:  External operation mode : STF/STR signal	166
	Both the forward and reverse rotation start signals (STF, STR) are input simultaneously.	Turn ON only one of the forward and reverse rotation start signals (STF or STR). When the STF and STR signals are turned ON simultaneously, a stop command is given.	20
	Frequency command is zero.	Check the frequency command source and enter a frequency command. (When the frequency command is 0Hz and the run command is entered, RUN LED of the operation panel flickers.)	166
	AU signal is not ON when terminal 4 is used for frequency setting.	Turn ON the AU signal. Turning ON the AU signal activates terminal 4 input.	20
	Output stop signal (MRS) or reset signal (RES) is ON.	Turn MRS or RES signal OFF. Inverter starts the operation with a given start command and a frequency command after turning OFF MRS or RES signal. Before turning OFF, ensure the safety.	113, 246
	Jumper connector of sink - source is wrongly selected.	Check that the control logic switchover jumper connector is correctly installed. If it is not installed correctly, input signal is not recognized.	22
	Shorting wires between S1 and SC, S2 and SC are disconnected.	Short between S1 and SC, S2 and SC with shorting wires.	20
	Voltage/current input switch is not correctly set for analog input signal (0 to 5V/0 to 10V, 4 to 20mA).	Set Pr. 73, Pr. 267, and a voltage/current input switch correctly, then input an analog signal in accordance with the setting.	20
	 was pressed. (Operation panel indication is <i>PS</i> (PS).)	During the External operation mode, check the method of restarting from a  input stop from PU.	250
Two-wire or three-wire type connection is wrong.	Check the connection. Connect STOP signal when three-wire type is used.	115	

Check points	Possible Cause	Countermeasures	Refer to page
<b>Parameter Setting</b>	<i>Pr. 0 Torque boost</i> setting is improper when V/F control is used.	Increase <i>Pr. 0</i> setting by 0.5% increments while observing the rotation of a motor. If that makes no difference, decrease the setting.	71
	<i>Pr. 78 Reverse rotation prevention selection</i> is set.	Check the <i>Pr. 78</i> setting. Set <i>Pr. 78</i> when you want to limit the motor rotation to only one direction.	160
	<i>Pr. 79 Operation mode selection</i> setting is wrong.	Select the operation mode which corresponds with input methods of start command and frequency command.	166
	Bias and gain ( <i>calibration parameter C2 to C7</i> ) settings are improper.	Check the bias and gain ( <i>calibration parameter C2 to C7</i> ) settings.	151
	<i>Pr. 13 Starting frequency</i> setting is greater than the running frequency.	Set running frequency higher than <i>Pr. 13</i> . The inverter does not start if the frequency setting signal is less than the value set in <i>Pr. 13</i> .	96
	Frequency settings of various running frequency (such as multi-speed operation) are zero. Especially, <i>Pr. 1 Maximum frequency</i> is zero.	Set the frequency command according to the application. Set <i>Pr. 1</i> higher than the actual frequency used.	81
	<i>Pr. 15 Jog frequency</i> setting is lower than <i>Pr. 13 Starting frequency</i> .	Set <i>Pr. 15 Jog frequency</i> higher than <i>Pr. 13 Starting frequency</i> .	89
	Operation mode and a writing device do not match.	Check <i>Pr. 79, Pr. 338, Pr. 339, Pr. 551</i> , and select an operation mode suitable for the purpose.	163, 174
	Start signal operation selection is set by the <i>Pr. 250 Stop selection</i>	Check <i>Pr. 250</i> setting and connection of STF and STR signals.	115
	Inverter decelerated to a stop when power failure deceleration stop function is selected.	When power is restored, ensure the safety, and turn OFF the start signal once, then turn ON again to restart. Inverter restarts when <i>Pr. 261</i> ="2".	140
Performing auto tuning.	When offline auto tuning ends, press  of the operation panel for the PU operation. For the External operation, turn OFF the start signal (STF or STR). This operation resets the offline auto tuning, and the PU's monitor display returns to the normal indication. (Without this operation, next operation cannot be started.)	103	
Automatic restart after instantaneous power failure function or power failure stop function is activated. (Performing overload operation with single-phase power input specification model may cause voltage insufficiency, and results in a detection of power failure.)	<ul style="list-style-type: none"> <li>Disable the automatic restart after instantaneous power failure function and power failure stop function.</li> <li>Reduce the load.</li> <li>Increase the acceleration time if the automatic restart after instantaneous power failure function or power failure stop function occurred during acceleration.</li> </ul>	134, 140	
<b>Load</b>	Load is too heavy.	Reduce the load.	—
	Shaft is locked.	Inspect the machine (motor).	—
<b>Others</b>	Operation panel display shows an error (e.g. E.OC1).	When any fault occurs, take an appropriate corrective action, then reset the inverter, and resume the operation.	247

**5.5.2 Motor or machine is making abnormal acoustic noise**

Check points	Possible Cause	Countermeasures	Refer to page
<b>Input signal</b>	Disturbance due to EMI when frequency command is given from analog input (terminal 2, 4).	Take countermeasures against EMI.	38
<b>Parameter Setting</b>		Increase the <i>Pr. 74 Input filter time constant</i> if steady operation cannot be performed due to EMI.	150
<b>Parameter Setting</b>	No carrier frequency noises (metallic noises) are generated.	In the initial setting, <i>Pr. 240 Soft-PWM operation selection</i> is enabled to change motor noise to an unoffending complex tone. Therefore, no carrier frequency noises (metallic noises) are generated. Set <i>Pr. 240</i> = "0" to disable this function.	146
	Resonance occurs. (output frequency)	Set <i>Pr. 31 to Pr. 36 (Frequency jump)</i> . When it is desired to avoid resonance attributable to the natural frequency of a mechanical system, these parameters allow resonant frequencies to be jumped.	82
	Resonance occurs. (carrier frequency)	Change <i>Pr. 72 PWM frequency selection</i> setting. Changing the PWM carrier frequency produces an effect on avoiding the resonance frequency of a mechanical system or a motor.	146
	Auto tuning is not performed under General-purpose magnetic flux vector control.	Perform offline auto tuning.	103
	Gain adjustment during PID control is insufficient.	To stabilize the measured value, change the proportional band ( <i>Pr. 129</i> ) to a larger value, the integral time ( <i>Pr. 130</i> ) to a slightly longer time, and the differential time ( <i>Pr. 134</i> ) to a slightly shorter time. Check the calibration of set point and measured value.	210
<b>Others</b>	Mechanical looseness	Adjust machine/equipment so that there is no mechanical looseness.	—
<b>Motor</b>	Operating with output phase loss	Check the motor wiring.	—
	Contact the motor manufacturer.		



**5.5.3 Inverter generates abnormal noise**

Check points	Possible Cause	Countermeasures	Refer to page
Fan	Fan cover was not correctly installed when a cooling fan was replaced.	Install a fan cover correctly.	272

**5.5.4 Motor generates heat abnormally**

Check points	Possible Cause	Countermeasures	Refer to page
Motor	Motor fan is not working (Dust is accumulated.)	Clean the motor fan. Improve the environment.	—
	Phase to phase insulation of the motor is insufficient.	Check the insulation of the motor.	—
Main Circuit	The inverter output voltage (U, V, W) are unbalanced.	Check the output voltage of the inverter. Check the insulation of the motor.	267
Parameter Setting	The Pr. 71 Applied motor setting is wrong.	Check the Pr. 71 Applied motor setting.	101
—	Motor current is large.	Refer to "5.5.11 Motor current is too large"	268

**5.5.5 Motor rotates in the opposite direction**

Check points	Possible Cause	Countermeasures	Refer to page
Main Circuit	Phase sequence of output terminals U, V and W is incorrect.	Connect phase sequence of the output cables (terminal U, V, W) to the motor correctly	15
Input signal	The start signals (forward rotation, reverse rotation) are connected improperly.	Check the wiring. (STF: forward rotation, STR: reverse rotation)	20
	A adjustment by the output frequency is improper during the reversible operation with Pr. 73 Analog input selection setting.	Check the setting of Pr. 125, Pr. 126, C2 to C7.	150
Parameter Setting	Pr. 40 RUN key rotation direction selection setting is incorrect.	Check the Pr. 40 setting.	235

**5.5.6 Speed greatly differs from the setting**

Check points	Possible Cause	Countermeasures	Refer to page
Input signal	Frequency setting signal is incorrectly input.	Measure the input signal level.	—
	The input signal lines are affected by external noise.	Take countermeasures against EMI such as using shielded wires for input signal lines.	38
Parameter Setting	Pr. 1, Pr. 2, Pr. 18, calibration parameter C2 to C7 settings are improper.	Check the settings of Pr. 1 Maximum frequency, Pr. 2 Minimum frequency, Pr. 18 High speed maximum frequency.	81
		Check the calibration parameter C2 to C7 settings.	151
Load	Pr. 31 to Pr. 36 (frequency jump) settings are improper.	Narrow down the range of frequency jump.	82
Parameter Setting		Reduce the load weight.	—
Motor		Set Pr. 22 Stall prevention operation level higher according to the load. (Setting Pr. 22 too large may result in frequent overcurrent trip (E.O.C).)	77
Motor	Stall prevention is activated due to a heavy load.	Check the capacities of the inverter and the motor.	—

## 5.5.7 Acceleration/deceleration is not smooth



Check points	Possible Cause	Countermeasures	Refer to page
Parameter Setting	Acceleration/deceleration time is too short.	Increase acceleration/deceleration time.	94
	Torque boost (Pr. 0, Pr. 46) setting is improper under V/F control, so the stall prevention function is activated.	Increase/decrease Pr. 0 Torque boost setting value by 0.5% increments to the setting.	71
	The base frequency does not match the motor characteristics.	For V/F control, set Pr. 3 Base frequency and Pr. 47 Second V/F (base frequency).	83
		For General-purpose magnetic flux vector control, set Pr. 34 Rated motor frequency.	103
	Stall prevention function is activated due to a heavy load.	Reduce the load weight.	—
		Set Pr. 22 Stall prevention operation level higher according to the load. (Setting Pr. 22 too large may result in frequent overcurrent trip (E.O.C).)	77
		Check the capacities of the inverter and the motor.	—
Regeneration avoidance operation is performed	If the frequency becomes unstable during regeneration avoidance operation, decrease the setting of Pr. 386 Regeneration avoidance voltage gain.	224	

## 5.5.8 Speed varies during operation



When the slip compensation is selected, the output frequency varies between 0 and 2Hz as with load fluctuates.

Check points	Possible Cause	Countermeasures	Refer to page
Input signal	Multi-speed command signal is chattering.	Take countermeasures to suppress chattering.	—
Load	Load varies during an operation.	Select General-purpose magnetic flux vector control.	73
Input signal	Frequency setting signal is varying.	Check the frequency reference signal.	—
	The frequency setting signal is affected by EMI.	Set filter to the analog input terminal using Pr. 74 Input filter time constant.	150
		Take countermeasures against EMI, such as using shielded wires for input signal lines.	38
Malfunction is occurring due to the undesirable current generated when the transistor output unit is connected.	Use terminal PC (terminal SD when source logic) as a common terminal to prevent a malfunction caused by undesirable current.	23	
Parameter Setting	Pr. 30 Motor capacity setting is improper for the capacities of the inverter and the motor for General-purpose magnetic flux vector control.	Check the Pr. 30 Motor capacity setting.	73
	Fluctuation of power supply voltage is too large.	Change the Pr. 19 Base frequency voltage setting (about 3%) under V/F control.	83
	Hunting occurs by the generated vibration, for example, when structural rigidity at load side is insufficient.	Disable automatic control functions, such as energy saving operation, fast-response current limit function, regeneration avoidance function, General-purpose magnetic flux vector control, and stall prevention. Adjust so that the control gain decreases and the level of safety increases.	—
		Change Pr. 72 PWM frequency selection setting.	146
Others	Wiring length exceeds 30m when General-purpose magnetic flux vector control is performed.	Perform offline auto tuning.	103
	Wiring length is too long for V/F control, and a voltage drop occurs.	Adjust Pr. 0 Torque boost by increasing with 0.5% increments for low-speed operation.	71
		Change to General-purpose magnetic flux vector control.	73

## 5.5.9 Operation mode is not changed properly

Check points	Possible Cause	Countermeasures	Refer to page
Input signal	Start signal (STF or STR) is ON.	Check that the STF and STR signals are OFF. When either is ON, the operation mode cannot be changed.	163
Parameter Setting	Pr. 79 setting is improper.	When Pr. 79 <i>Operation mode selection</i> setting is "0" (initial value), the inverter is placed in the External operation mode at input power ON. To switch to the PU operation mode, press  on the operation panel (press  when the parameter unit (FR-PU04/FR-PU07) is used). At other settings (1 to 4, 6, 7), the operation mode is limited accordingly.	163
	Operation mode and a writing device do not correspond.	Check Pr. 79, Pr. 338, Pr. 339, Pr. 551, and select an operation mode suitable for the purpose.	163, 174

## 5.5.10 Operation panel display is not operating

Check points	Possible Cause	Countermeasures	Refer to page
Main Circuit	Wiring or installation is improper.	Check for the wiring and the installation.	14
		Make sure that the connector is fitted securely across terminal P/+ to P1.	
Main Circuit Control Circuit	Power is not input.	Input the power.	14
Parameter Setting	Command sources at the PU operation mode is not at the operation panel. (None of the operation mode displays (  ) is lit.)	Check the setting of Pr. 551 <i>PU mode operation command source selection</i> . (If parameter unit (FR-PU04/FR-PU07) is connected while Pr. 551 = "9999" (initial setting), all the operation mode displays (  ) turn OFF.)	174

## 5.5.11 Motor current is too large

Check points	Possible Cause	Countermeasures	Refer to page	
Parameter Setting	Torque boost (Pr. 0, Pr. 46) setting is improper under V/F control, so the stall prevention function is activated.	Increase/decrease Pr. 0 <i>Torque boost</i> setting value by 0.5% increments to the setting.	71	
	V/F pattern is improper when V/F control is performed. (Pr. 3, Pr. 14, Pr. 19)	Set rated frequency of the motor to Pr. 3 <i>Base frequency</i> . Use Pr. 19 <i>Base frequency voltage</i> to set the base voltage (e.g. rated motor voltage).		83
		Change Pr. 14 <i>Load pattern selection</i> according to the load characteristic.		85
		Reduce the load weight.		—
	Stall prevention function is activated due to a heavy load.	Set Pr. 22 <i>Stall prevention operation level</i> higher according to the load. (Setting Pr. 22 too large may result in frequent overcurrent trip (E.O.C).)		77
		Check the capacities of the inverter and the motor.		—
Auto tuning is not performed under General-purpose magnetic flux vector control.	Perform offline auto tuning.		103	

## 5.5.12 Speed does not accelerate

Check points	Possible Cause	Countermeasures	Refer to page
Input signal	Start command and frequency command are chattering.	Check if the start command and the frequency command are correct.	—
	The wiring length used for analog frequency command is too long, and it is causing a voltage (current) drop.	Perform analog input bias/gain calibration.	151
	Input signal lines are affected by external EMI.	Take countermeasures against EMI, such as using shielded wires for input signal lines.	38
Parameter Setting	Pr. 1, Pr. 2, Pr. 18, calibration parameter C2 to C7 settings are improper.	Check the settings of Pr. 1 Maximum frequency and Pr. 2 Minimum frequency. If you want to run the motor at 120Hz or higher, set Pr. 18 High speed maximum frequency.	81
		Check the calibration parameter C2 to C7 settings.	151
	Torque boost (Pr. 0, Pr. 46) setting is improper under V/F control, so the stall prevention function is activated.	Increase/decrease Pr. 0 Torque boost setting value by 0.5% increments so that stall prevention does not occur.	71
	V/F pattern is improper when V/F control is performed. (Pr. 3, Pr. 14, Pr. 19)	Set rated frequency of the motor to Pr. 3 Base frequency. Use Pr. 19 Base frequency voltage to set the base voltage (e.g. rated motor voltage).	83
		Change Pr. 14 Load pattern selection according to the load characteristic.	85
	Stall prevention is activated due to a heavy load.	Reduce the load weight.	—
		Set Pr. 22 Stall prevention operation level higher according to the load. (Setting Pr. 22 too large may result in frequent overcurrent trip (E.O.C).)	77
Check the capacities of the inverter and the motor.		—	
Auto tuning is not performed under General-purpose magnetic flux vector control.	Perform offline auto tuning.	103	
During PID control, output frequency is automatically controlled to make measured value = set point.		210	
Main Circuit	Brake resistor is connected between terminal P/+ and P1 by mistake.	Connect an optional brake transistor (MRS type, MYS type, FR-ABR) between terminal P/+ and PR.	30

## 5.5.13 Unable to write parameter setting

Check points	Possible Cause	Countermeasures	Refer to page
Input signal	Operation is being performed (signal STF or STR is ON).	Stop the operation. When Pr. 77 = "0" (initial value), write is enabled only during a stop.	159
Parameter Setting	You are attempting to set the parameter in the External operation mode.	Choose the PU operation mode. Or, set Pr. 77 = "2" to enable parameter write regardless of the operation mode.	159
	Parameter is disabled by the Pr. 77 Parameter write selection setting.	Check Pr. 77 Parameter write selection setting.	159
	Key lock is activated by the Pr. 161 Frequency setting/key lock operation selection setting.	Check Pr. 161 Frequency setting/key lock operation selection setting.	236
	Operation mode and a writing device do not correspond.	Check Pr. 79, Pr. 338, Pr. 339, Pr. 551, and select an operation mode suitable for the purpose.	163, 174



*End of Publication*