

***INK JET
SYSTEM
WITH DRYER BASE
BRYCE***

Parts Manual



SURE-FEED
engineering, inc.

3360 Scherer Drive St. Petersburg, FL 33716

PHONE: 727.571.3330 FAX: 727.571.3443 1-800-INSERTER

www.sure-feed.com

Z

TABLE OF CONTENTS

I. INKJET SYSTEM W/ DRYER BASE ASSEMBLY (FIG. 1).....4

A. Frame Assembly, Inkjet Base (Fig. 2).....7

B. Frame Assembly, Dryer Base (Fig. 3).....9

C. Conveyor Drive Assembly, Inkjet (Fig. 4).....11

 1. Motor / Drive Shaft Assembly (Fig. 5).....13

 2. Idler Pulley / Tensioner Assembly (Fig. 6).....15

 3. Idler Pulley / Belt Guide Assembly (Fig. 7).....17

 4. Encoder Assembly (Fig. 8).....19

D. Conveyor Drive Assembly, Dryer Base (Fig. 9).....21

 1. Drive Shaft / Tensioner Assembly (Fig. 10).....23

 2. Idler Pulley / Belt Guide Assembly (Fig. 11).....25

E. Inkjet Bridge Assembly (Fig. 12).....27

F. Hold Down Guide Assembly (Fig. 13).....29

G. Adjustable Sensor Assembly (Fig. 14).....31

H. Vacuum Assembly (Fig. 15).....33

II. ELECTRICAL ASSEMBLY

A. Electrical Console, Inkjet (Fig. 16).....35

B. Receptacle / Plug Assembly (Fig. 17).....37

C. Motor Drive Enclosure Assembly (Fig. 18).....39

 1. Din Rail Assembly (Fig. 19).....41

 2. Receptacle Assembly (Fig. 20).....43

D. Transformer Enclosure Assembly (Fig. 21).....45

E. Dryer Enclosure Assembly (Fig. 22).....47

 1. Electrical Components Assembly (Fig. 23).....49

III. FEEDER BASE / FEEDER ASSEMBLY (FIG. 24).....51

A. Feeder Base Assembly (Fig. 25).....53

B. SJ30 Feeder Assembly (Fig. 26).....55

 1. Separator Device Assembly (Fig. 27).....57

 2. Side Guide Assembly (Fig. 28).....59

 3. Front / Nip / Support Assembly (Fig. 29).....61

 4. Main / Jack / Elevator Assembly (Fig. 30).....63

 5. Paper Slide Assembly (Fig. 31).....65

 6. Chassis / Electrical Assembly (Fig. 32).....67

 7. Trailing Arm Assembly (Fig. 33).....69

IV. SPEED UP CONVEYOR ASSEMBLY (FIG. 34).....71

A. Drive Shaft / Motor Assembly (Fig. 35).....73

B. Idler Shaft Assembly (Fig. 36).....75

C. Knock Down Plate Assembly (Fig. 37).....77

Sure-Feed
Engineering Inc

INK JET SYSTEM
W/ DRYER BASE

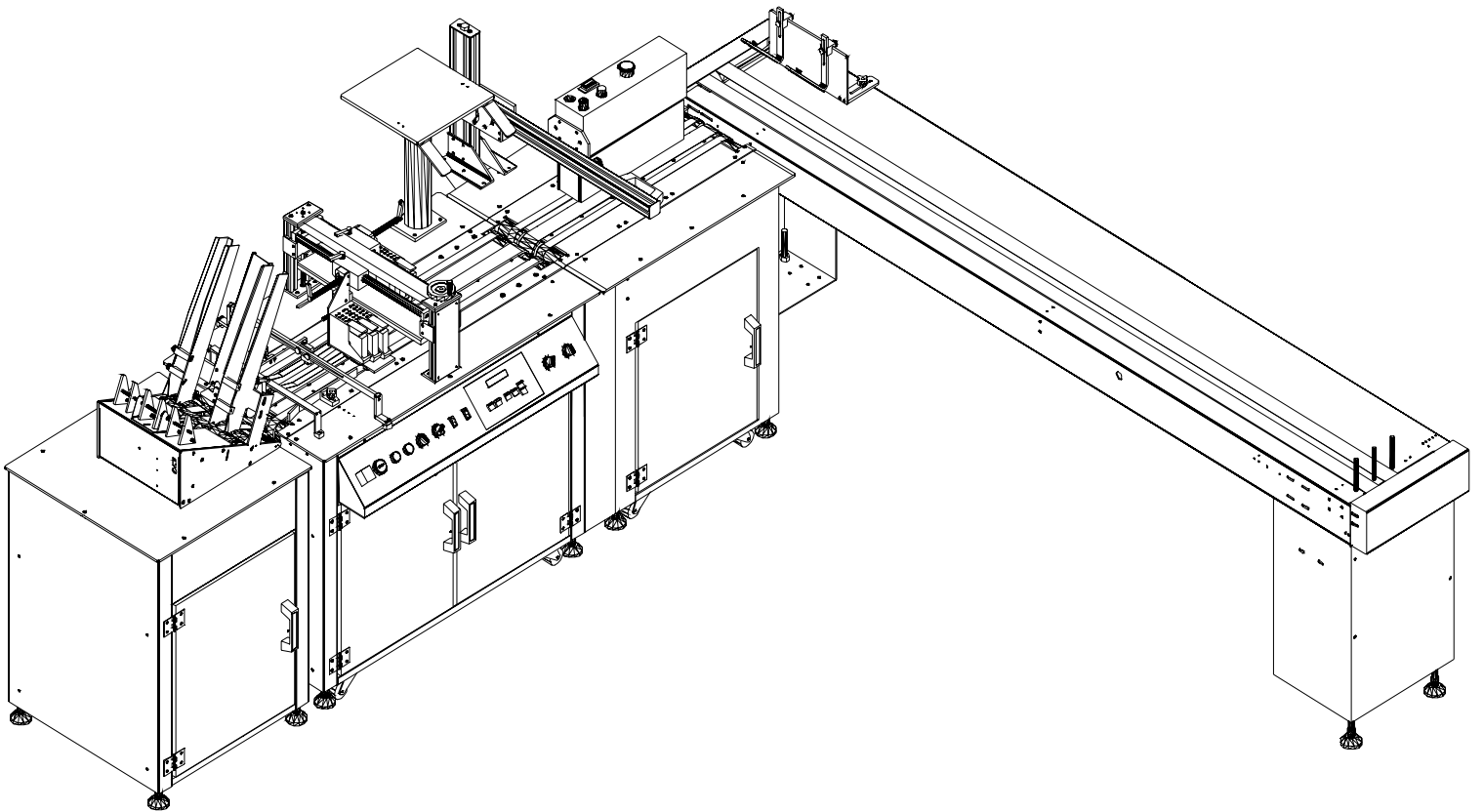

Sure-Feed
Engineering Inc

INK JET SYSTEM W/ DRYER ASSEMBLY (Fig. 1)

ITEM	PART NO.	QTY.	DESCRIPTION
1	SEE FIG. 2	1	FRAME ASSEMBLY (INK JET SYSTEM)
2	SEE FIG. 3	1	FRAME ASSEMBLY (DRYER CONVEYOR)
3	SEE FIG. 4-8	1	CONVEYOR BELT DRIVE ASSEMBLY (INK JET SYS.)
4	SEE FIG. 9-11	1	CONVEYOR DRIVE ASSEMBLY (DRYER CONVEYOR)
5	SEE FIG 12	1	INKJET BRIDGE ASSEMBLY
6	98021-001	1	DRYER ASSEMBLY
7	SEE FIG. 15	1	VACUUM ASSEMBLY
8	SEE FIG. 14	1	HOLD DOWN ASSEMBLY
9	SEE FIG. 15	1	ADJUSTABLE SENSOR ASSEMBLY
10	16012-006	4	SPACER, CABINET STIFFENING
11	16011-015	2	PANEL, INK JET / DRYER MTG.
12	16011-049	2	BRACKET, TIE-IN, FEEDER BASE – INKJET BASE
13	16000-003	1	STAND, MONITOR
14	16009-001	2	BRACKET, KEYBOARD
15	NOT SHOWN	4	SCREW, SKT HD, 3/8-16 X 3/4 (MONITOR STAND MTG.)
16	NOT SHOWN	4	WASHER, FLAT, 3/8 (MONITOR STAND MTG.)
17	NOT SHOWN	4	SCREW, SKT HD, 10-24 X 1/2 (KEYBOARD BRACKET)
18	NOT SHOWN	4	WASHER, FLAT, #10 (KEY BOARD BRACKET MTG.)
19	NOT SHOWN	8	SCREW, SKT HD, 1/4-20 X 1 (DRYER SUPPORT BLOCK)
20	NOT SHOWN	1	ELECTRICAL ASSEMBLY (SEE FIG. 16-20)
21	NOT SHOWN	4	SCREW, FLAT HD, 6-32 X 1/2 (CABINET SPACER)
22	NOT SHOWN	2	SCREW, SKT HD, 14-20 X 3/4 (CABINET SPACER)

Sure-Feed
Engineering Inc

FIG. 1

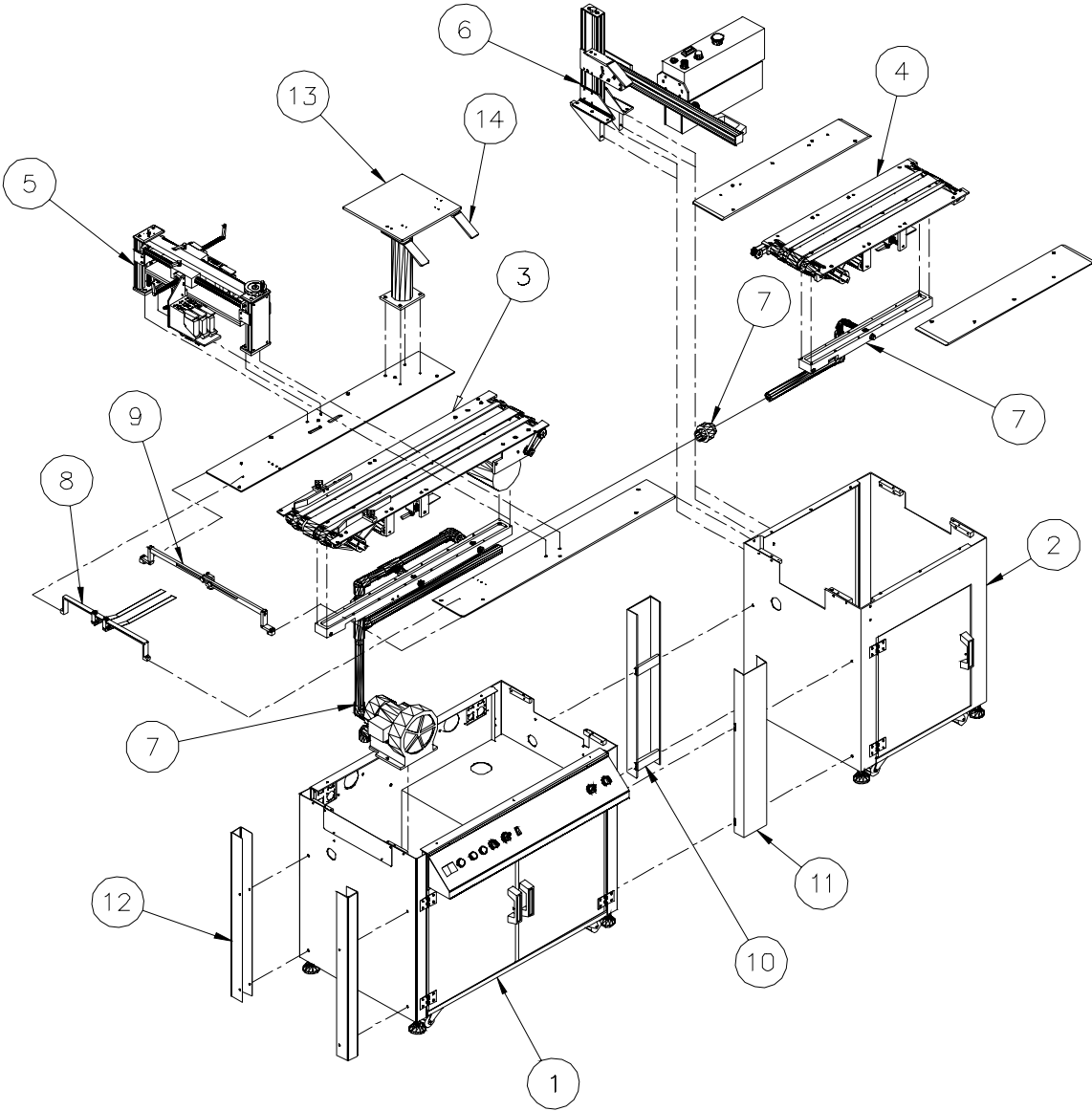

Sure-Feed
Engineering Inc

INK JET SYSTEM (Fig. 2)
FRAME ASSEMBLY

ITEM	PART NO.	QTY.	DESCRIPTION
1	16000-002	1	BASE, FRAME WELDMENT, INK JET
2	16011-003	1	PLATE, INK JET, TOP CENTER
3	16011-001	1	PLATE, INK JET, TOP RH
4	16011-002	1	PLATE, INK JET, TOP LH
5	16013-007	1	ENCLOSURE, ELECTRICAL CONSOLE
6	16013-005	1	DOOR, RH
7	16013-006	1	DOOR. LH
8	16013-009	1	COVER, END
9	16011-009	2	PLATE, RECEPTICAL MOUNTING
10	16007-003	4	BLOCK, TOP PLATE MTG.
11	99012-001	2	HANDLE, DOOR
12	99011-002	4	HINGE, DOOR
13	16013-013	2	HINGE, ELECTRICAL CONSOLE
14	99013-001	2	LATCH, DOOR
15	99010-001	4	FOOT, ADJUSTABLE, 5/8-11
16	99010-002	4	CASTER, 2"
17	16013-011	2	PAN, BLADDER (OPTIONAL)
18	16009-007	2	BRACKET, BLADDER PAN SUPPORT (OPTIONAL)
19	16008-005	4	BAR, BLADDER PAN MTG (OPTIONAL)
20		16	SCREW, SKT HD, 1/4-20 X 5/8
21		10	SCREW, BUTTON HD, 10-24 X 1/2
22		14	SCREW, FLAT HD, 10-24 X 5/8
23		4	SCREW, SKT HD, 1/4-20 X 1-1/4
24		4	SCREW, SKT HD, 1/4-20 X 1/2
25		8	POP RIVOT, #10
26	NOT SHOWN	4	NUT, HEX, 5/8-11 (ADJ. FOOT)
27	NOT SHOWN	16	NUT, HEX, 1/4-20 (DOOR HINGE)
28	NOT SHOWN	16	WASHER, FLAT, 1/4 (DOOR HINGE)
29	NOT SHOWN	8	SCREW, BUT. HD, 10-24 X 3/8 (ELECT. CONS. HINGE)

Sure-Feed
Engineering Inc

INK JET SYSTEM (Fig. 2)
FRAME ASSEMBLY CONTINUED

ITEM	PART NO.	QTY.	DESCRIPTION
30	NOT SHOWN	8	NUT, HEX, 10-24 (ELECT. CONS. HINGE)
31	NOT SHOWN	8	WASHER, FLAT, #10 (ELECT. CONS. HINGE)
32	NOT SHOWN	16	SCREW, HEX HD, 5/16-18 X 3/4 (WHEELS)
33	NOT SHOWN	16	WASHER, LOCK, 5/16 (WHEELS)
34	NOT SHOWN	16	WASHER, FLAT, 5/16 (WHEELS)
35	NOT SHOWN	16	NUT, HEX, 5/16-18 (WHEELS)

Sure-Feed
Engineering Inc

DRYER CONVEYOR (Fig. 3)
FRAME ASSEMBLY

ITEM	PART NO.	QTY.	DESCRIPTION
1	16000-004	1	BASE, FRAME WELDMENT, DRYER CONVEYOR
2	16011-012	1	PLATE, DRYER, TOP CENTER
3	16011-014	1	PLATE, DRYER, TOP LH
4	16011-013	1	PLATE, DRYER, TOP RH
5	19013-001	1	DOOR, RH
6	16007-014	4	BLOCK, TOP PLATE MTG.
7	99012-001	1	HANDLE, DOOR
8	99013-001	1	LATCH, DOOR
9	99010-001	4	FOOT, ADJUSTABLE, 5/8-11
10	99010-002	4	CASTER, 2"
11	99011-002	2	HINGE, DOOR
12		8	SCREW, SKT HD, 1/4-20 X 5/8
13		8	SCREW, BUTTON HD, 10-24 X 1/2
14		14	SCREW, FLAT HD, 10-24 X 5/8
15	NOT SHOWN	4	NUT, HEX, 5/8-11 (ADJ. FOOT)
16	NOT SHOWN	8	NUT, HEX, 1/4-20 (DOOR HINGE)
17	NOT SHOWN	8	WASHER, FLAT, 1/4 (DOOR HINGE)
18	NOT SHOWN	16	SCREW, HEX HD, 5/16-18 X 3/4 (WHEELS)
19	NOT SHOWN	16	WASHER, LOCK, 5/16 (WHEELS)
20	NOT SHOWN	16	WASHER, FLAT, 5/16 (WHEELS)
21	NOT SHOWN	16	NUT, HEX, 5/16-18 (WHEELS)

FIG. 3

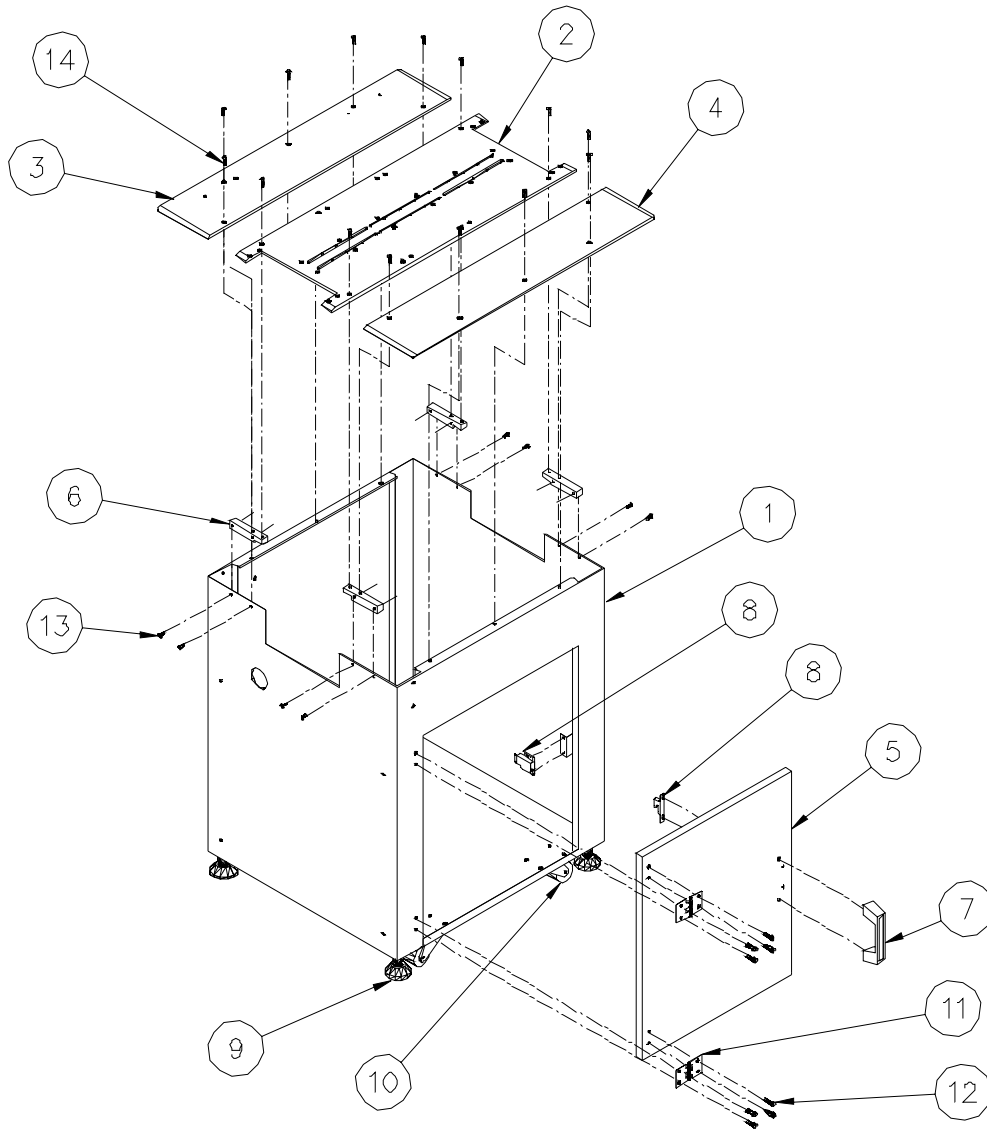

**INKJET SYSTEM (Fig. 4)
 CONVEYOR DRIVE ASSEMBLY**

ITEM	PART NO.	QTY.	DESCRIPTION
1	16011-003	1	PLATE, INK JET, TOP CENTER (REF. FIG. 2)
2	16007-004	1	BLOCK, MANIFOLD
3	SEE FIG. 5	1	MOTOR / DRIVE SHAFT ASSEMBLY
4	SEE FIG. 6	1	PULLEY IDLER / TENSIONER ASSEMBLY
5	SEE FIG. 7	1	PULLEY IDLER / BELT GUIDE ASSEMBLY
6	SEE FIG. 8	1	ENCODER MOUNTING ASSEMBLY
7	12007-008	2	BLOCK, SIDE GUIDE MTG.
8	12005-010	1	GUIDE, SIDE, LH
9	12005-009	1	GUIDE, SIDE, RH
10	99004-019	2	KNOB, MALE, #10-24 X 3/4
11	16014-005	1	BELT, VACUUM, SET
12		16	SCREW, FLAT HD, 1/4-20 X 5/8
13		2	SCREW, SKT HD, 1/4-20 X 3/4
14		2	SCREW, FLAT HD, 8-32 X 1/2
15	NOT SHOWN	16	SCREW, FLAT HD, 10-24 X 1/2 (MANIFOLD MTG.)

FIG. 4

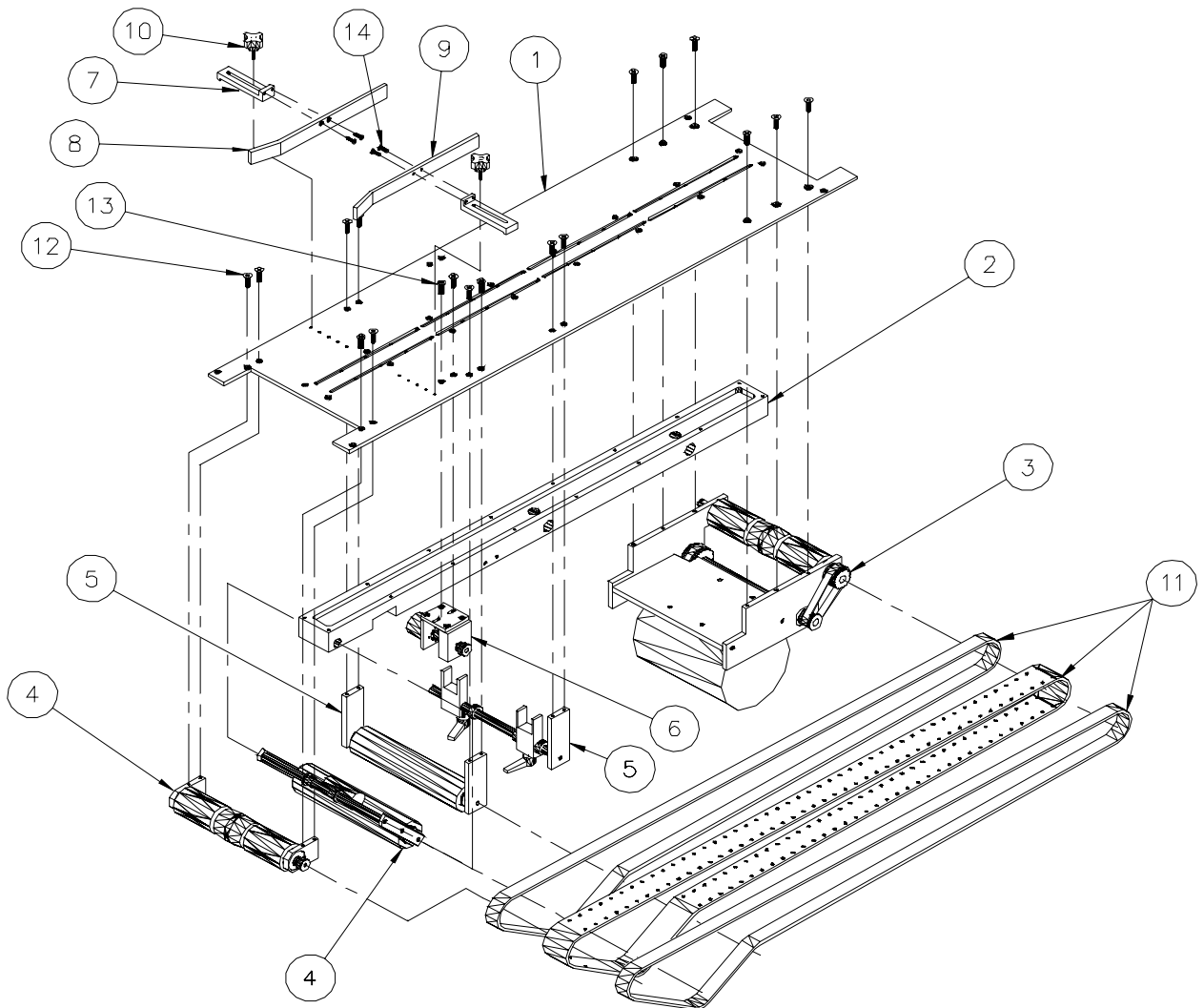

Sure-Feed
Engineering Inc

INK JET SYSTEM – CONVEYOR DRIVE (Fig. 5)
MOTOR / DRIVE SHAFT ASSEMBLY

ITEM	PART NO.	QTY.	DESCRIPTION
1	16011-008	1	PLATE, MOTOR MTG.
2	16011-004	2	PLATE, MOTOR MTG. SUPPORT
3	99001-011	1	MOTOR, 1/3 HP, 48 FRAME
4	16004-027	2	SHAFT, DRIVE (STUB)
5	16004-010	1	SHAFT, INTERMEDIATE
6	16006-007	1	PULLEY, 28XL075, 1/2 BORE
7	16006-006	1	PULLEY, 22XL075, 1/2 BORE
8	16006-005	2	PULLEY, 14XL075, 1/2 BORE
9	16006-009	1	PULLEY, 18XL075, 1/2 BORE W/ FLANGES
10	16006-020	1	PULLEY, DRIVE
11	99000-059	1	BELT, TIMING, 130XL075
12	99000-060	1	BELT, TIMING, 100XL075
13	99000-064	1	BELT, TIMING, 90XL075
14	99003-006	4	BEARING, SEALED, 5/8 X 1-3/8
15	99003-021	4	WASHER, NYLON, 5/8 X 1/16
16	99017-005	1	COLLAR, SET, 5/8
17		4	SCREW, SKT HD, 5/16-18 X 5/8
18		4	SCREW, SKT HD, 1/4-20 X 1
19		4	WASHER, LOCK, 5/16
20		4	WASHER, FLAT, 5/16

FIG. 5

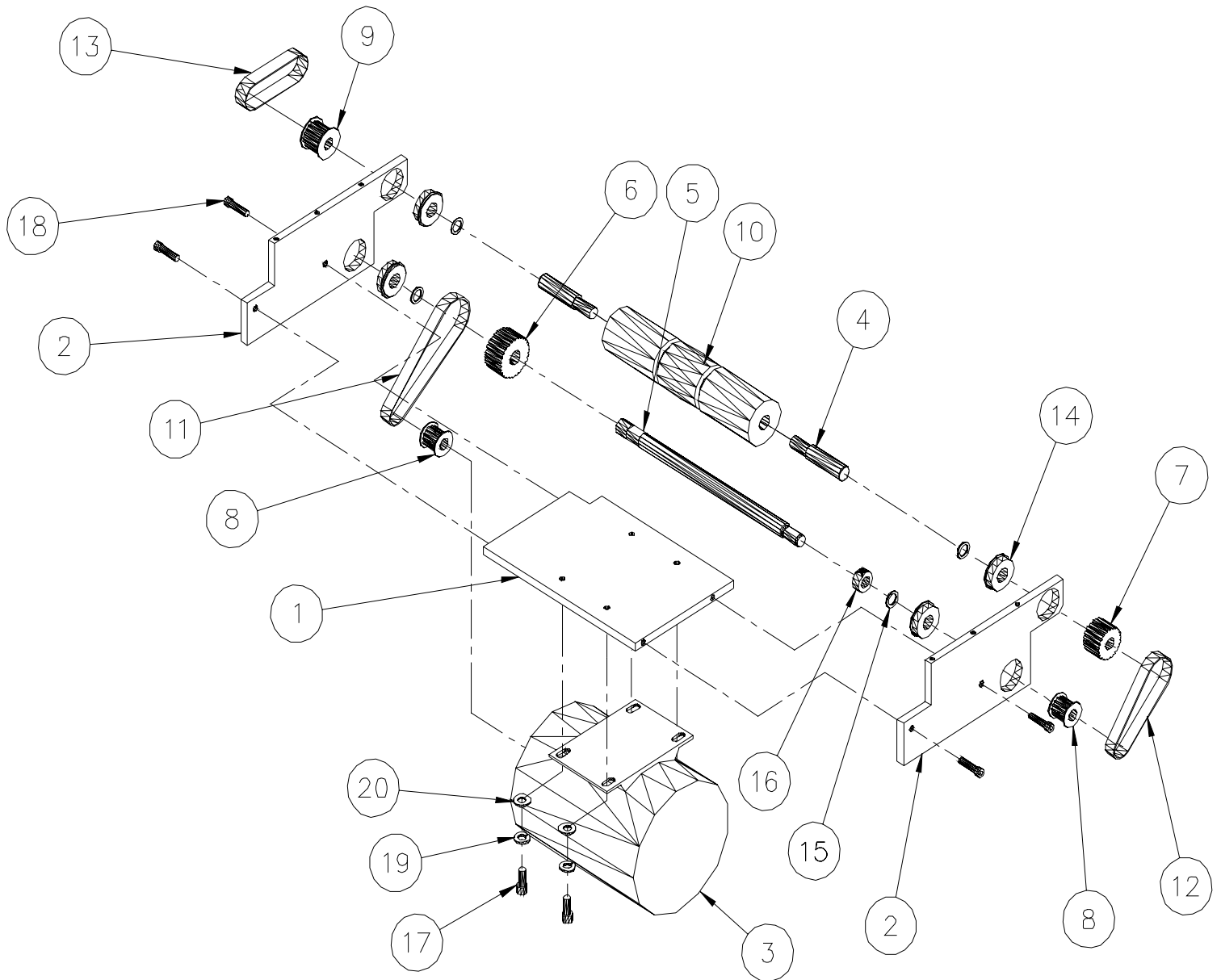

Sure-Feed
Engineering Inc

INK JET SYSTEM – CONVEYOR DRIVE (Fig. 6)
IDLER PULLEY / TENSIONER ASSEMBLY

ITEM	PART NO.	QTY.	DESCRIPTION
1	16007-004	1	BLOCK, MANIFOLD (REF. FIG. 4)
2	16007-002	2	BLOCK, BEARING
3	16008-021	2	BAR, IDLER TENSIONER
4	16004-028	2	SHAFT, IDLER (STUB)
5	16004-004	2	SHAFT, PIVOT
6	16004-003	1	SHAFT, TENSIONER
7	16006-020	1	PULLEY, DRIVE
8	16006-002	1	PULLEY, IDLER
9	16006-003	1	ROLLER, ECCENTRIC
10	99003-006	2	BEARING, SEALED, 5/8 X 1-3/8
11	99003-007	2	BEARING, SEALED, 1/2 X 1-1/8
12	99003-018	12	WASHER, NYLON, 1/2 X 1/16
13	99003-032	2	WASHER, NYLON, 1/2 X 1/32
14	99003-021	2	WASHER, NYLON, 5/8 X 1/16
15	99003-043	2	BUSHING, FL, 1/2 X 5/8 X 1/2
16		6	SCREW, SOCKET HD, 1/4-20 X 3/4

FIG. 6

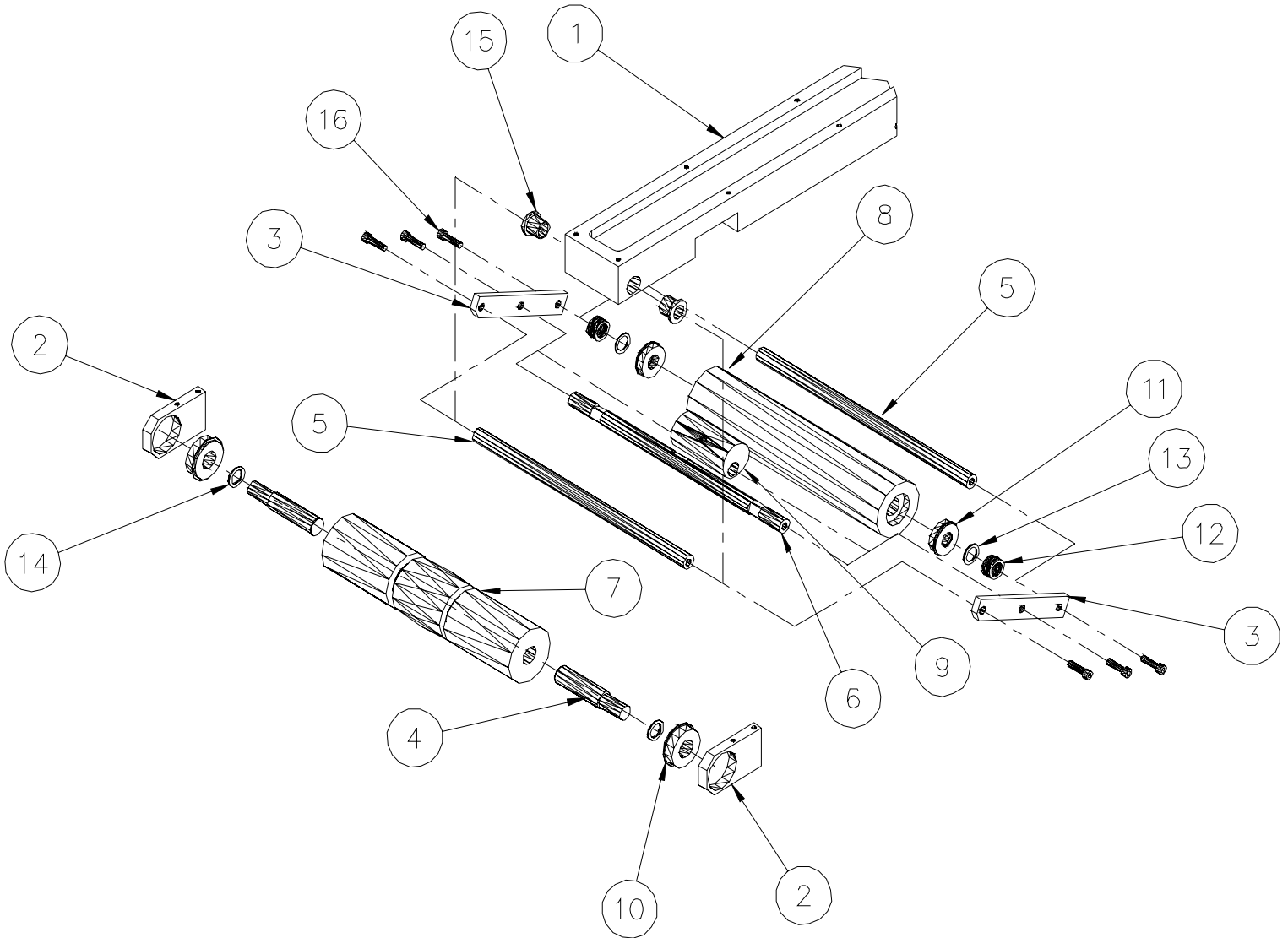

Sure-Feed
Engineering Inc

INK JET SYSTEM – CONVEYOR DRIVE (Fig. 7)
IDLER PULLEY / BELT GUIDE ASSEMBLY

ITEM	PART NO.	QTY.	DESCRIPTION
1	16009-002	3	BRACKET, BELT GUIDE SUPPORT
2	16005-001	2	BLOCK, 1" BELT GUIDE
3	16006-002	1	PULLEY, IDLER
4	16004-004	1	SHAFT, PIVOT
5	16004-011	1	SHAFT, BELT GUIDE SUPPORT
6	99003-007	2	BEARING, SEALED, 1/2 X 1-1/8
7	99003-018	12	WASHER, NYLON, 1/2 X 1/16
8	99003-032	2	WASHER, NYLON, 1/2 X 1/32
9	99017-004	4	COLLAR, SET, 1/2
10		4	SCREW, BUTTON HD, 10-24 X 3/8

FIG. 7

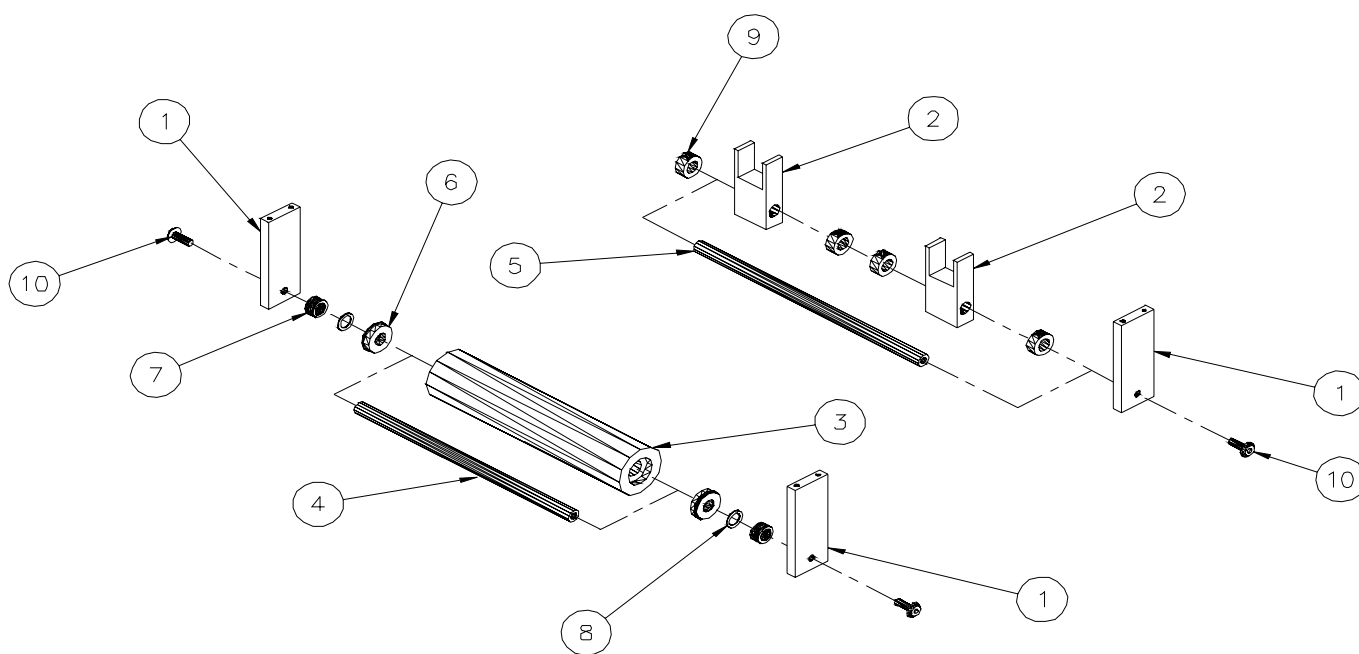

Sure-Feed
Engineering Inc

INK JET SYSTEM (Fig. 8)
ENCODER MOUNTING ASSEMBLY

ITEM	PART NO.	QTY.	DESCRIPTION
1	16011-003	1	PLATE, INK JET TOP, CENTER
2	16011-020	1	PLATE, SIDE, SHAFT MOUNT
3	16011-019	1	PLATE, SIDE, ENCODER MOUNT
4	16011-018	1	PLATE, MAIN, ENCODER MOUNT
5	98017-003	1	ENCODER (DYNAPER)
6	99002-061	1	PULLEY, TIMING, 25 MP025
7	99017-024	1	HELICAL COUPLING
8	99003-002	2	BEARING, 1/4" X 5/8", SEALED
9	99000-097	1	BELT, TIMING, 232MXL
10		2	SCREW, FLAT HEAD, 10-24 X 1"
11		4	SCREW, FLAT HEAD, 10-24 X 1/2"

FIG. 8

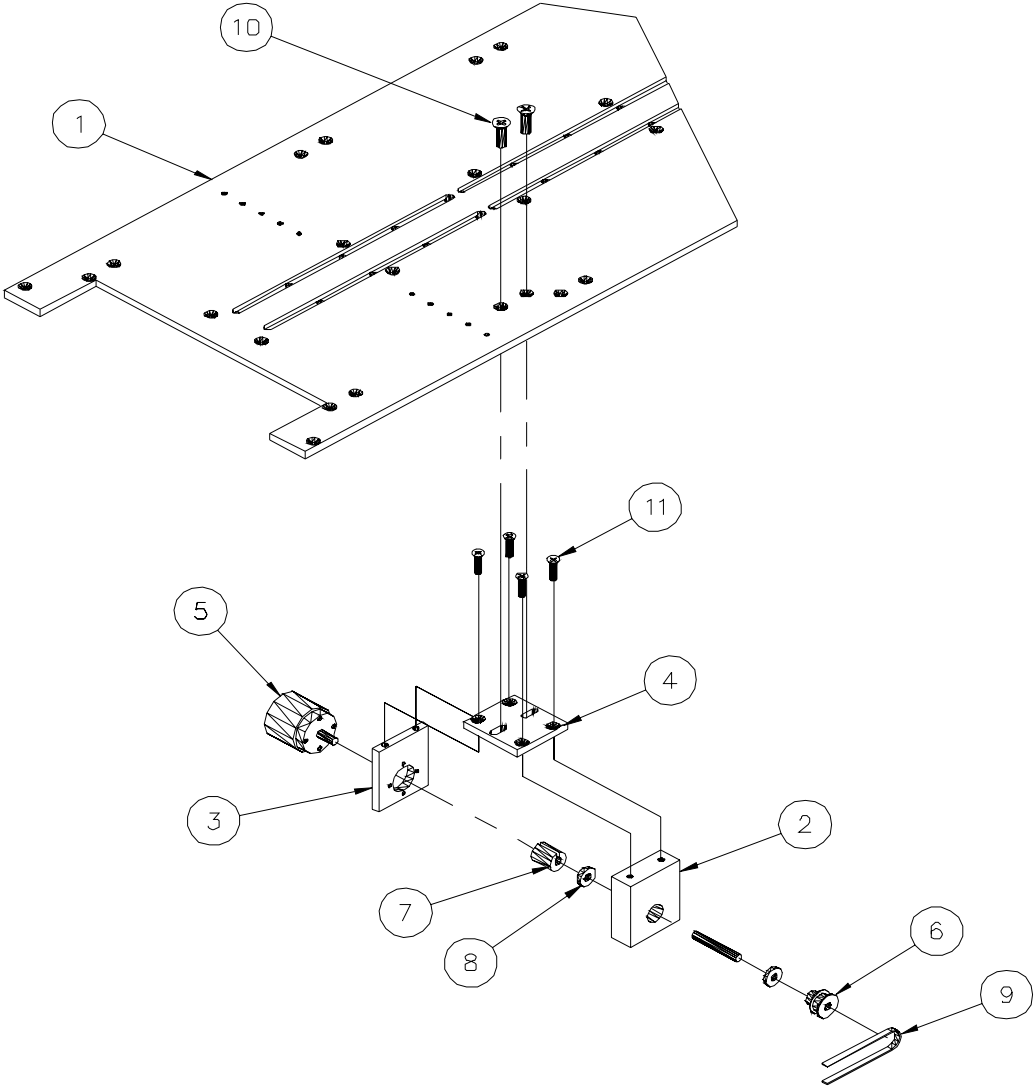

Sure-Feed
Engineering Inc

DRYER CONVEYOR (Fig. 9)
CONVEYOR DRIVE ASSEMBLY

ITEM	PART NO.	QTY.	DESCRIPTION
1	16011-012	1	PLATE, DRYER, CENTER (REF. FIG. 2)
2	16007-012	1	BLOCK, MANIFOLD, DRYER CONVEYER
3	SEE FIG.10	1	DRIVE SHAFT / TENSIONER ASSEMBLY
4	SEE FIG. 11	1	PULLEY IDLER / BELT GUIDE ASSEMBLY
5	16014-002	1	BELT, HI-TEMP, 2" WIDE X 62.50
6	99000-061	2	BELT, HI-TEMP, 1" WIDE X 62.50
7		14	SCREW, FLAT HD, 1/4-20 X 5/8
8	NOT SHOWN	12	SCREW, FLAT HD, 10-24 X 1/2 (MANIFOLD MTG.)

FIG. 9

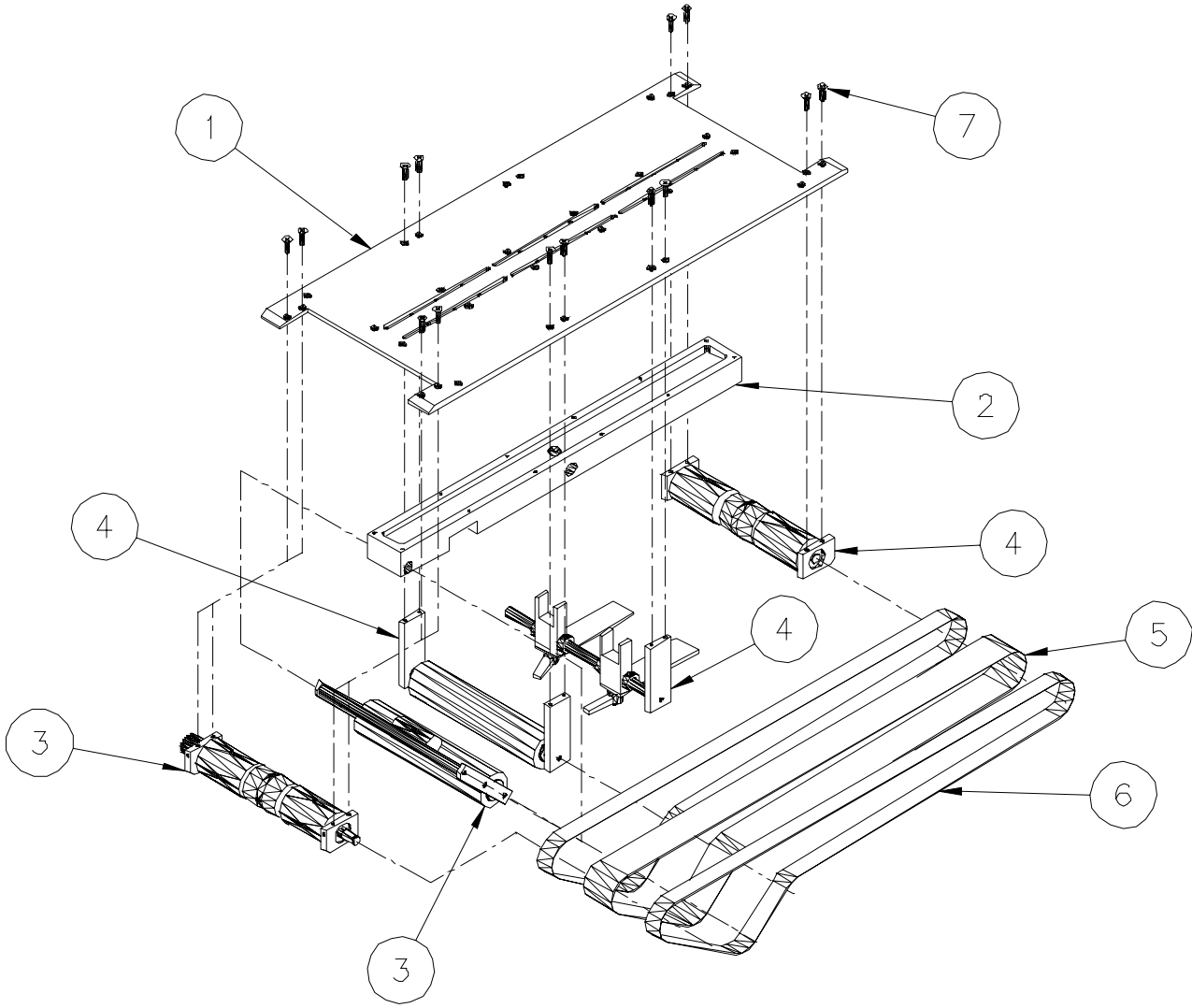

Sure-Feed
Engineering Inc

DRYER CONVEYOR – CONVEYOR DRIVE (Fig. 10)
DRIVE SHAFT / TENSIONER ASSEMBLY

ITEM	PART NO.	QTY.	DESCRIPTION
1	16007-012	1	BLOCK, MANIFOLD, DRYER (REF. FIG. 8)
2	16007-013	2	BLOCK, BEARING
3	16008-021	2	BAR, IDLER TENSIONER
4	16004-027	2	SHAFT, DRIVE (STUB)
5	16004-004	2	SHAFT, PIVOT
6	16004-003	1	SHAFT, TENSIONER
7	16006-022	1	PULLEY, 18XL075, 1/2 BORE W/OUT FLANGES
8	16006-020	1	PULLEY, DRIVE
9	16006-002	1	PULLEY, IDLER
10	16006-003	1	PULLEY, ECCENTRIC
11	99003-007	2	BEARING, SEALED, 1/2 X 1-1/8
12	99003-063	2	BEARING, SEALED, 5/8 X 1-3/8 (HI TEMP GREASE)
13	99003-018	2	WASHER, NYLON, 1/2 X 1/16
14	99003-043	2	BUSHING, FL, 1/2 X 5/8 X 1/2
15		6	SCREW, SOCKET HD, 1/4-20 X 3/4
16	99022-004	4	SNAP RING, 1/2"
17	99022-008	2	SNAP RING, 5/8"
18	99003-021	2	WASHER, NYLON, 5/8 X 1/16

FIG. 10

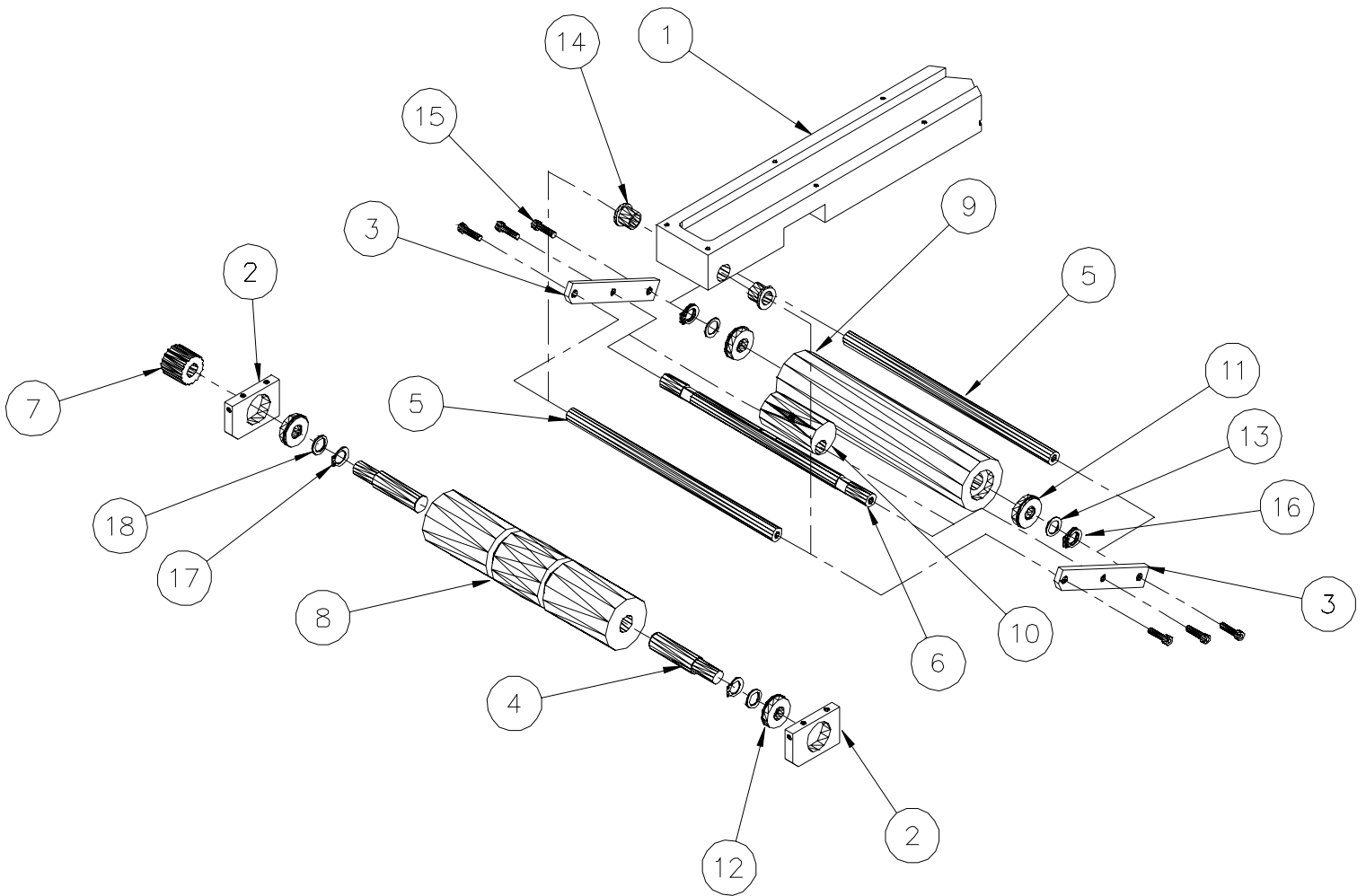

Sure-Feed
Engineering Inc

DRYER CONVEYOR – CONVEYOR DRIVE (Fig. 11)
IDLER PULLEY / BELT GUIDE ASSEMBLY

ITEM	PART NO.	QTY.	DESCRIPTION
1	16007-013	2	BLOCK, BEARING
2	16009-002	3	BRACKET, BELT GUIDE SUPPORT
3	16005-003	2	GUIDE, BELT, 1"
4	16004-028	1	SHAFT, IDLER (STUB)
5	16004-004	1	SHAFT, PIVOT
6	16004-011	1	SHAFT, BELT GUIDE SUPPORT
7	16006-020	1	PULLEY, DRIVE
8	16006-002	1	PULLEY, IDLER
9	99003-007	2	BEARING, SEALED, 1/2 X 1-1/8
10	99017-004	4	COLLAR, SET, 1/2
11	99003-018	2	WASHER, NYLON, 1/2 X 1/16
12		4	SCREW, BUTTON HD, 1/4-20 X 3/4
13	99003-063	2	BEARING, SEALED, 5/8 X 1-3/8
14	99022-004	4	SNAP RING, 1/2
15	99003-021	2	WASHER, NYLON, 5/8 X 1/16
16	99022-008	2	SNAP RING, 5/8"

FIG. 11

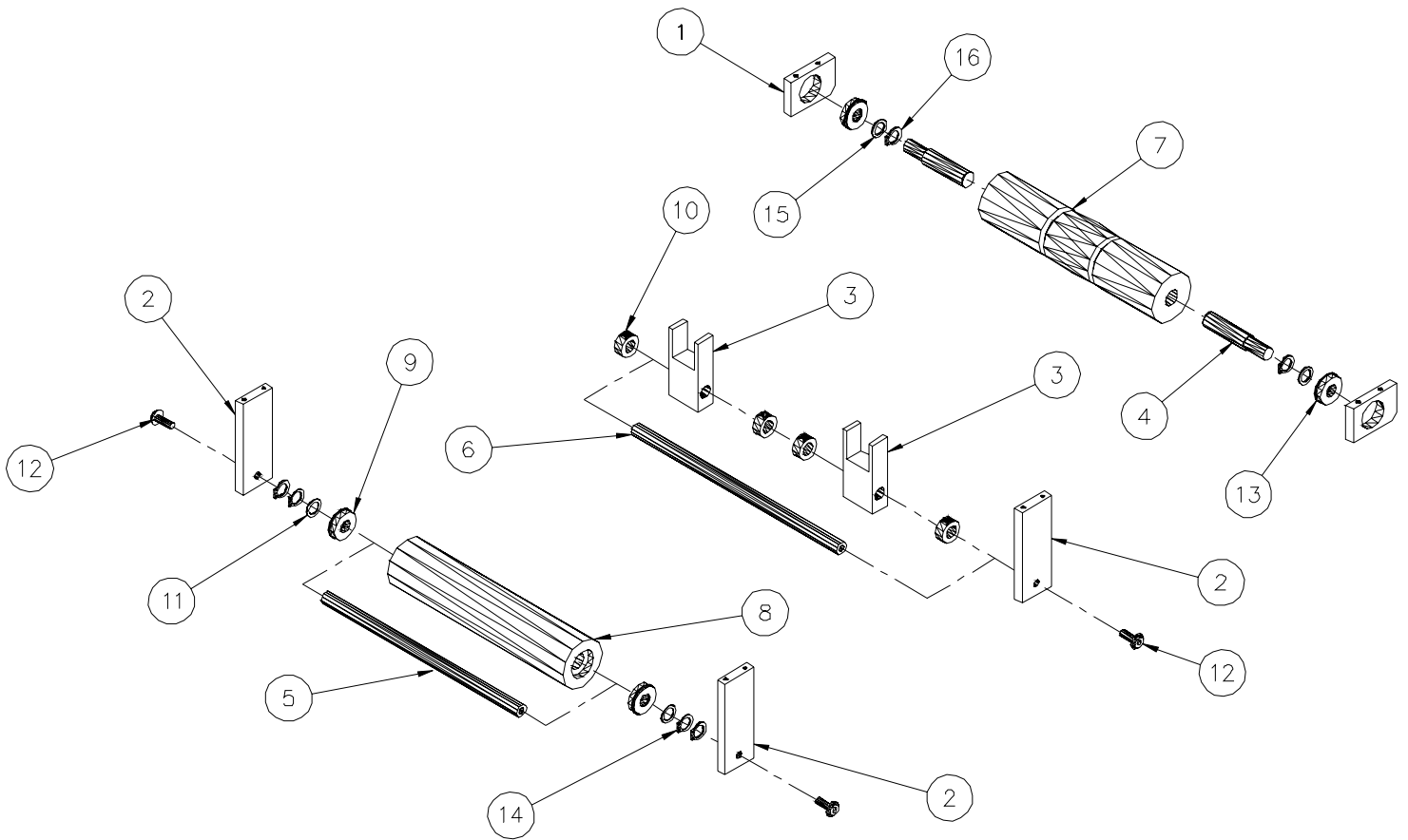

INKJET BRIDGE ASSEMBLY (Fig. 12)

ITEM	PART NO.	QTY.	DESCRIPTION
1	16011-037	2	PLATE, ADJUSTMENT, INKJET BRIDGE
2	16011-036	2	PLATE, BASE, INKJET BRIDGE
3	16011-038	2	PLATE, TOP, INKJET BRIDGE
4	99003-074	4	BEARING, 80/20 SGL FLG #6715
5	16011-034	2	PLATE, PRINT HEAD MTG, INKJET BRIDGE
6	16009-018	1	BRACKET, RH, PRINT HEAD MTG.
7	16009-019	1	BRACKET, LH, PRINthead MTG.
8	16007-029	2	BLOCK, PIVOT, PRINthead
9	16007-031	2	BLOCK, ADJUSTMENT, INKJET BRIDGE
10	16019-002	2	NUT, ADJUSTMENT, INKJET BRIDGE
11	16007-030	2	BLOCK, BUMPER MTG
12	16011-035	2	PLATE, COVER, INKJET BRIDGE
13	16008-016	4	RAIL, VERTICAL, INKJET BRIDGE
14	16008-017	2	RAIL, HORIZONTAL, INKJET BRIDGE
15	16007-036	1	BLOCK, BRACE, INKJET BRIDGE
16	99003-075	2	BEARING, 80/20 SGL FLG #6715 W
17	16013-026	1	SHIELD, BELT, INKJET BRIDGE
18	16004-025	1	SHAFT, ADJ (W/ KNOB)
19	16004-026	1	SHAFT, ADJ
20	99003-077	2	BUSHING, SLEEVE, 3/8 X 1/2 X 3/8
21	99003-076	4	BUSHING, FL, 1/4 X 3/8 X 3/8
22	99002-075	2	PULLEY, TIMING, 15XL037, 3/8 B
23	99000-119	1	BELT, TIMING, 460MXL037
24	99039-048	2	BUMPER, ADJ, 1/4-20 X 1-5/8
25	99033-016	2	BOLT, SHOULDER, 3/8 X 1/2
26	99004-025	2	HANDLE, RACHET, 10-24 X .78
27	99004-008	1	KNOB, W/ REVOLVING HANDLE

Sure-Feed Engineering Inc

FIG. 12

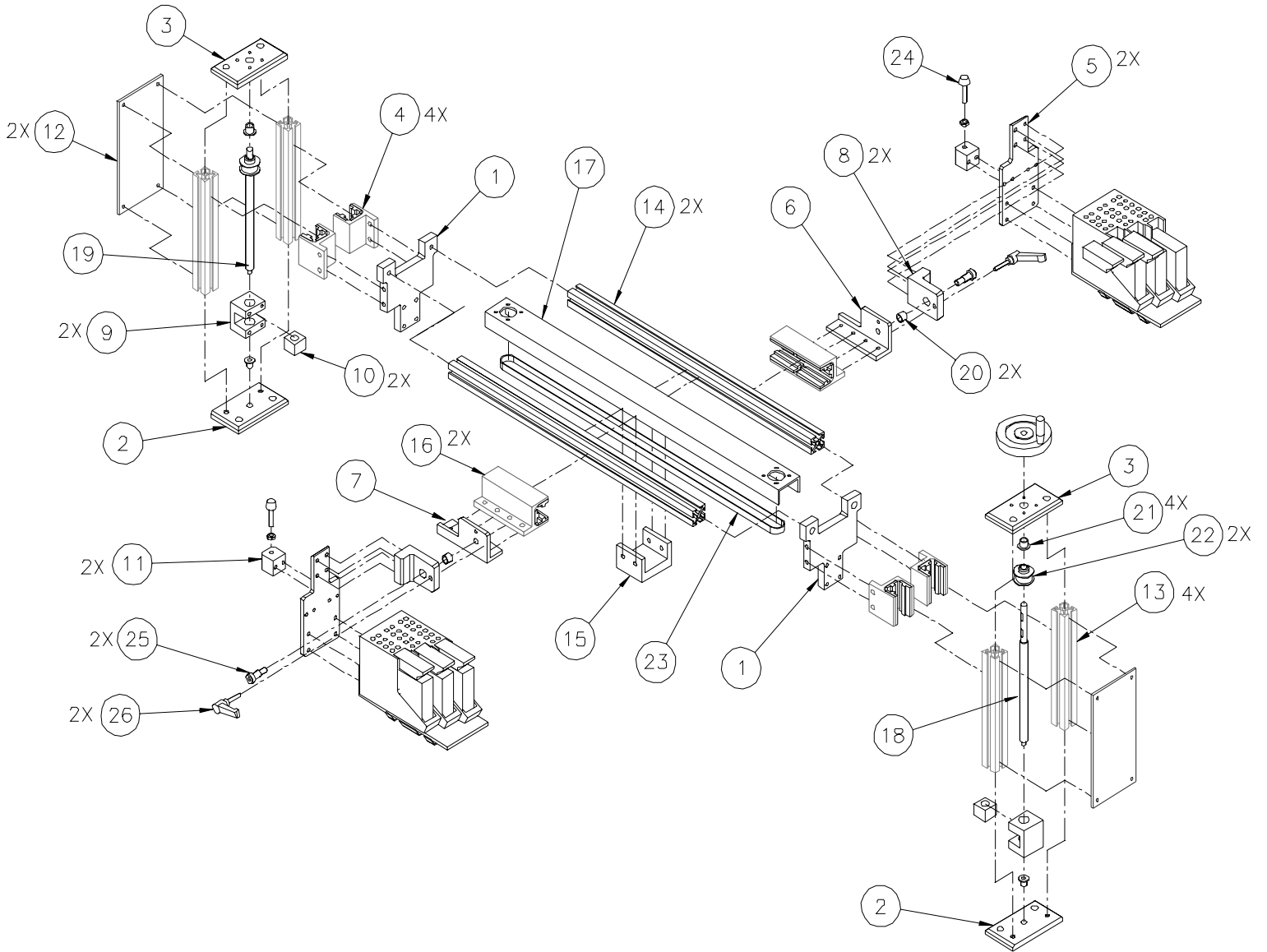

Sure-Feed
Engineering Inc

INK JET SYSTEM (Fig. 13)
HOLD DOWN GUIDE ASSEMBLY

ITEM	PART NO.	QTY.	DESCRIPTION
1	16008-007	1	BAR, DRAG STRAP MTG.
2	16009-008	2	BRACKET, DRAG STRAP SUPPORT
3	18009-014	2	BRACKET, DRAG STRAP MTG.
4	18009-029	2	BRACKET, DRAG STRAP PIVOT
5	18005-105	2	GUIDE, SPRING STEEL
6		2	SCREW, SKT HD, 10-24 X 1/2 W/ KNURLED CAP
7		4	SCREW, SKT HD, 8-32 X 1/2
8		2	SCREW, SKT HD, 8-32 X 1/4
9		4	SCREW, PAN HD, 6-32 X 1/4

FIG. 13

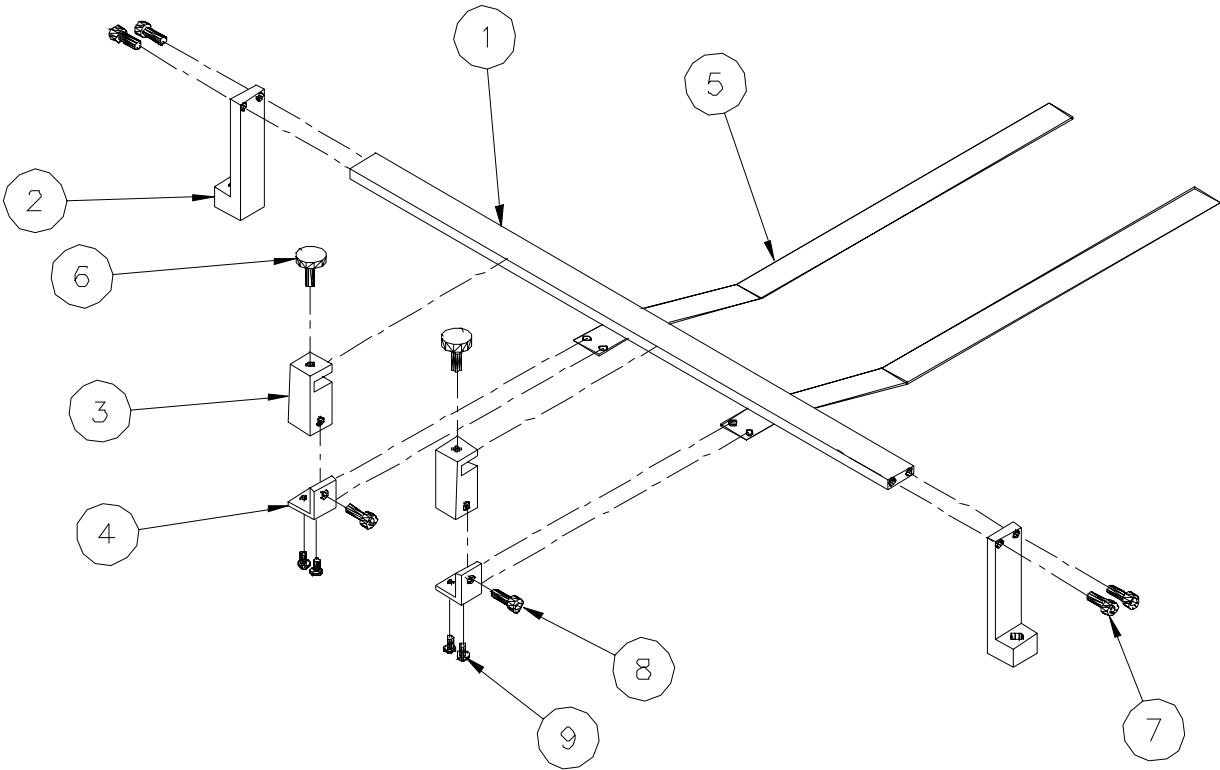

Sure-Feed
Engineering Inc

INK JET SYSTEM (Fig. 14)
ADJUSTABLE SENSOR ASSEMBLY

ITEM	PART NO.	QTY.	DESCRIPTION
1	16008-022	1	BAR, SENSOR ADJ, INKJET BASE
2	16007-034	2	BLOCK, SENSOR SUPPORT
3	16007-035	2	BLOCK, SENSOR CLAMP
4	16007-033	2	BLOCK, CLAMP
5	16011-016	1	PLATE, SENSOR MTG
6	98009-011	1	SENSOR, BRYCE, YELLOW W/ CABLE
7		2	SCREW, SKT HD, 10-24 X 3/4 (W/ KNURLED CAPS)

FIG. 14

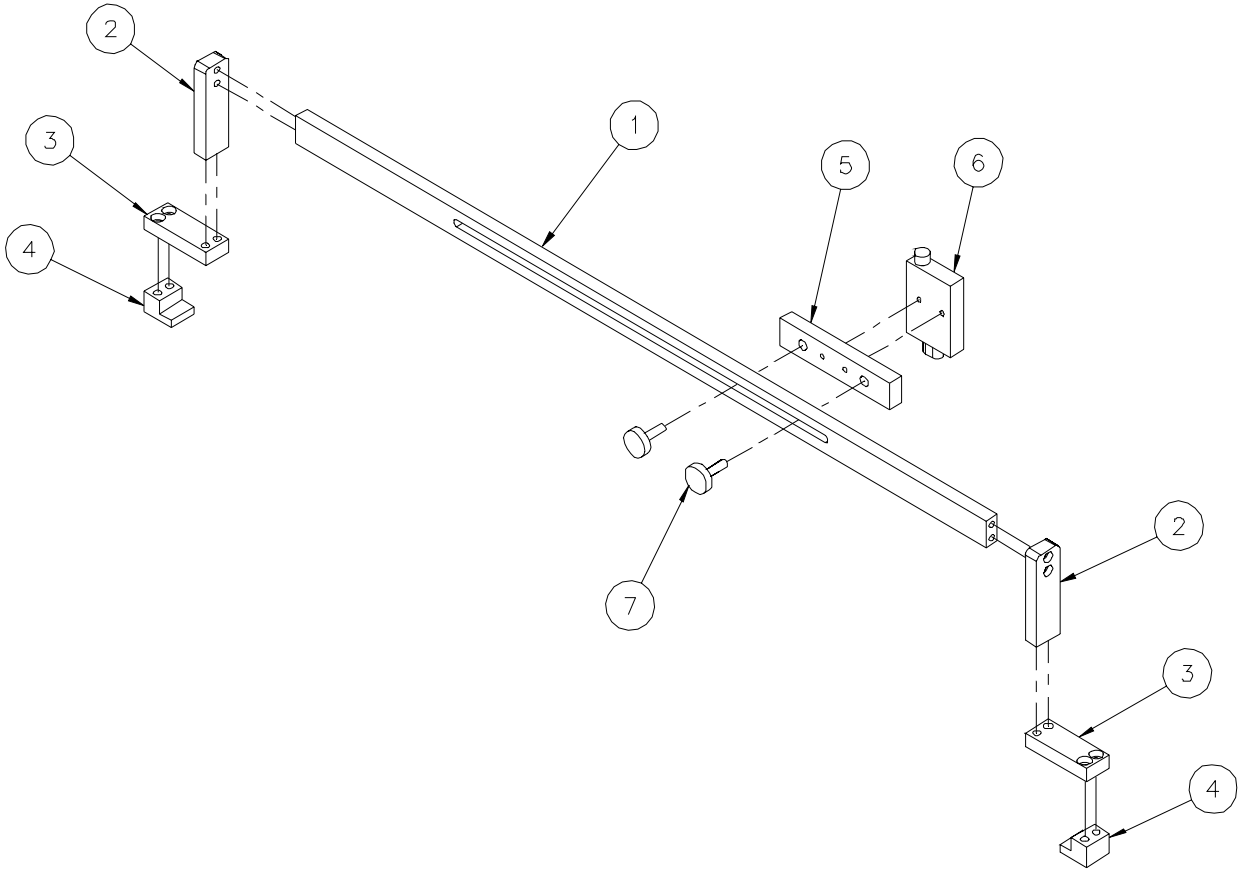

Sure-Feed
Engineering Inc

**INK JET SYSTEM / DRYER CONVEYOR (Fig. 15)
 VACUUM ASSEMBLY**

ITEM	PART NO.	QTY.	DESCRIPTION
1	99029-003	1	BLOWER, VACUUM
1	16007-004	1	BLOCK, MANIFOLD (INK JET) (REF. FIG. 6)
3	16007-012	1	BLOCK, MANIFOLD (DRYER) (REF. FIG. 10)
4	99028-048	12.5'	PIPE, PVC, 1"
5	99028-049	3	UNION, PVC, 1" NPT
6	99028-050	6	ELBOW, PVC, 1" NPT
7	99028-051	1	TEE, PVC, 1"
8	99028-052	1	TEE, REDUCING, PVC, 1" X 3/4
9	99028-046	1	ELBOW, STREET, PVC, 1" NPT X 1
10	99028-047	1	ADAPTER, MALE, PVC, 1" NPT X 1
11	99028-053	2	BUSHING, REDUCING, 1" X 3/4
12	99028-055	2	ADAPTOR, MALE, PVC, 3/4 NPT X 3/4
13	99028-054	1'	PIPE, PVC, 3/4
14	99031-006	1	HOSE, REINFORCED EDPM, 1" ID
15	16018-013	1	HOSE NIPPLE, BRASS, 3/4 NPT X 2"
16	99028-058	1	ELBOW, BRASS, 3/4
17	99028-057	1	NIPPLE, BRASS, 3/4 NPT X 4"
18	99028-056	2	PLUG, PVC, 3/4
19	99028-059	1	PLUG, BRASS, 3/4
20	99025-009	1	VALVE, VACUUM RELIEF, 3/8 NPT, 0-15 CFM

FIG. 15

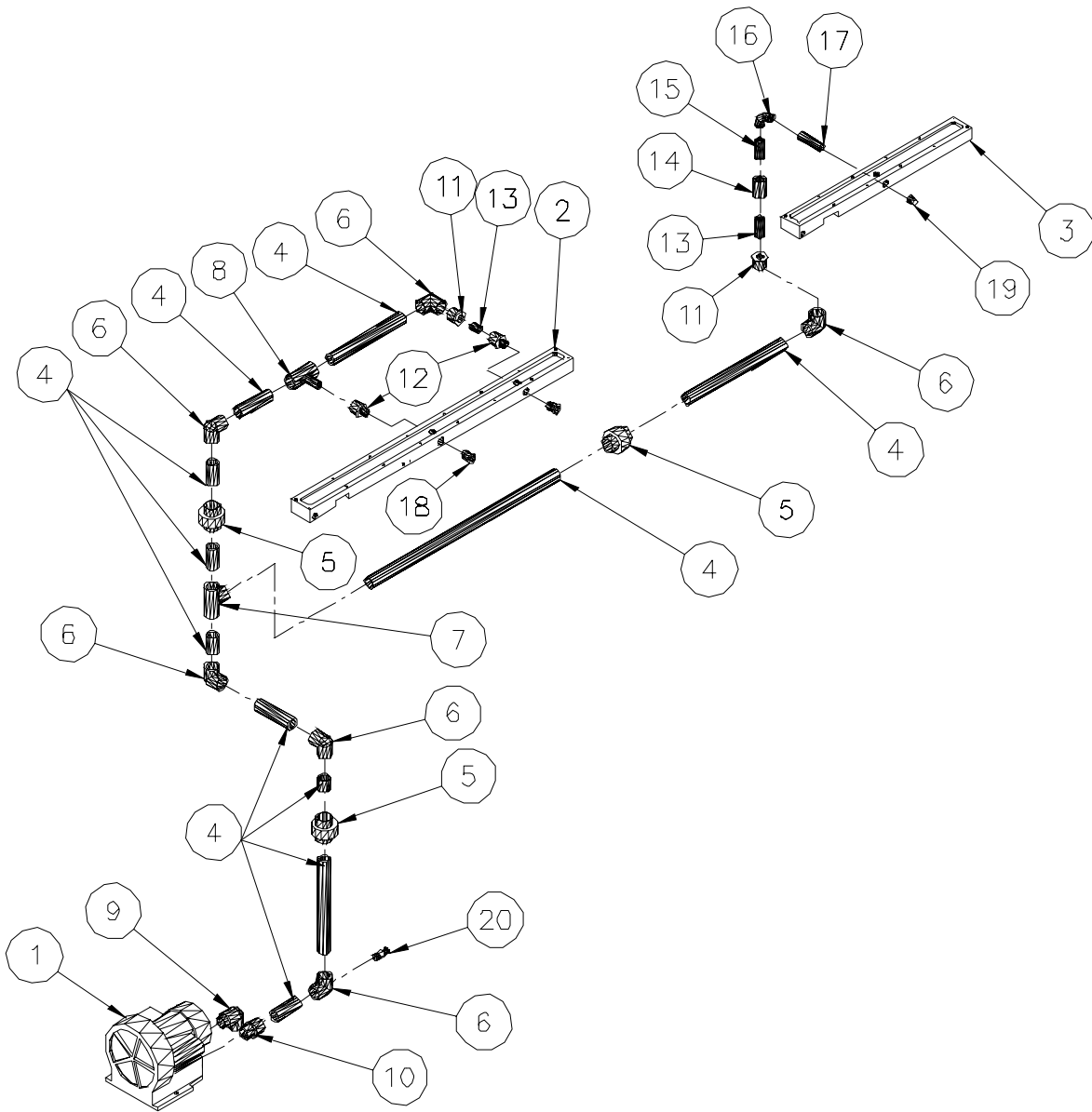

INK JET SYSTEM (Fig. 16)
ELECTRICAL CONSOLE

ITEM	PART NO.	QTY.	DESCRIPTION
1	16013-007	1	ENCLOSURE, ELECTRICAL CONSOLE
2	99004-015	4	KNOB, SPEED POT
3	98006-010	2	POT, SPEED CONTROL, 10K (NON-LINEAR)
4	98006-009	2	POT, SPEED CONTROL, 100K
5	98000-030	1	SWITCH, PUSH BUTTON, ROUND, GREEN
6	98000-031	1	SWITCH, PUSH BUTTON, ROUND, YELLOW
7	98000-027	2	CLIP, SWITCH ASSEMBLY (NOT SHOWN)
8	98000-028	2	CONTACT BLOCK, 1 X NO (NOT SHOWN)
9	98000-016	1	STOP BUTTON, PUSH / PULL, MUSHROOM HEAD
10	98000-017	1	CONTACT BLOCK, 1 X NO + 1 X NC + CLIP
11	98000-013	1	SWITCH, BLUE, AUXIMINI, 16MM RECT.
12	98000-001	2	SWITCH, POWER (ROCKER – RED)
13	98013-018	1	CONTROLLER, STANDARD OEM, BRYCE

FIG. 16

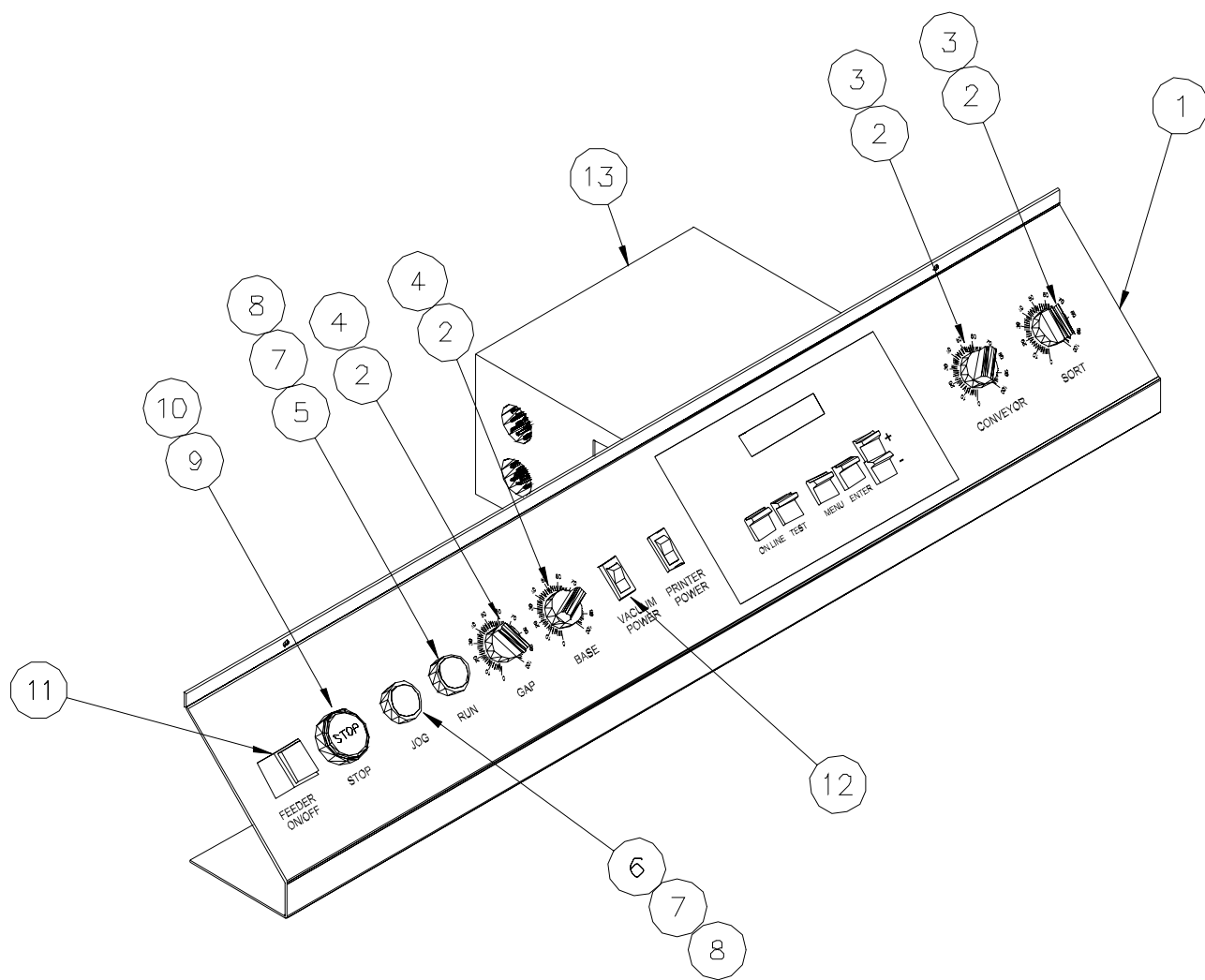

Sure-Feed
Engineering Inc

INK JET SYSYTEM - ELECTRICAL (Fig. 17)
RECEPTICAL / PLUG ASSEMBLY

ITEM	PART NO.	QTY.	DESCRIPTION
1	98003-014	1	RECEPT, HUBBLE, TWIST LOCK (20A, 125/250 VAC)
2	98016-010	1	RECEPTACLE, SQ FLANGE, AMP, 17-16 STD (MALE)
3	98016-091	1	RECEPTACLE, SQ FLANGE, AMP, 17-14 REV (FEMALE)
4	98016-128	1	SEALING CAP, SIZE 17
5	98016-010	1	RECEPTACLE, SQ FLANGE, AMP, 17-16 STD (MALE)
6	98003-015	1	RECEPT, FLANGED, HBL TWIST LOCK (15A, 125V)
7	16011-044	1	PLATE, RECEPT MTG, REAR RH SIDE
8	16011-043	1	PLATE, RECEPT MTG, REAR LH SIDE
9	98016-007	1	PLUG, AMP, 13-9 STD (FEMALE)
10	98016-008	1	BACKSHELL, PLASTIC, SIZE 13
11	98016-046	1	PLUG, AMP, 11-8 STD (FEMALE)
12	98016-015	1	BACKSHELL, PLASTIC, SIZE 11
13	98003-016	1	QUADBLOC, TYPE 4752 (RECEPT...15A, 250V)
14	98003-018	1	CONNECTOR (RECEPT), HBL TWIST LOCK (15A, 125V)
15	98003-017	1	PLUG, HUBBLE TWIST LOCK (20A, 250V)
16	98015-001	1	STRAIN RELIEF, 3/4"
17	98015-003	1	LOCKNUT, 3/4"
18	16013-036	2	COVER, WIRES

Sure-Feed
Engineering Inc

INK JET SYSYTEM - ELECTRICAL (Fig. 18)
MOTOR DRIVE ENCLOSURE ASSY

ITEM	PART NO.	QTY.	DESCRIPTION
1	SEE FIG. 16	1	ASSY, ELECTRICAL DIN RAIL
2	98012-003	77.5"	WIREWAY, 1" X 3" (W/ COVERS)
3	98013-044	2	MOTOR DRIVE, AC, 1/2 HP (VAR. SPEED)
4	98000-022	1	SWITCH ASSEMBLY, POWER DISCONNECT
4A	98000-024	1	SWITCH, NON-FUSIBLE DISCONNECT, 3 POLE, 40 AMP
4B	98000-026	1	SWITCH OPERATOR, RED/YELLOW NON-FUSIBLE DISCONNECT
4C	98000-025	1	SWITCH SHAFT, NON-FUSIBLE DISCONNECT
5	98008-005	1	TRANSFORMER, 28 VAC
6	98005-007	1	CONTROLLER, MOTOR, 90 VDC, 115/130 VAC
7	98002-005	2	SOCKET, RELAY, PRESSURE CLAMP TYPE
8	98002-007	2	RELAY, DPDT, 24V VDC
9	16013-044	1	BACKPLATE, MAIN ENCLOSURE
10	16013-042	1	ENCLOSURE, MAIN
11	16013-043	1	COVER, MAIN ENCLOSURE (NOT SHOWN)

FIG. 18

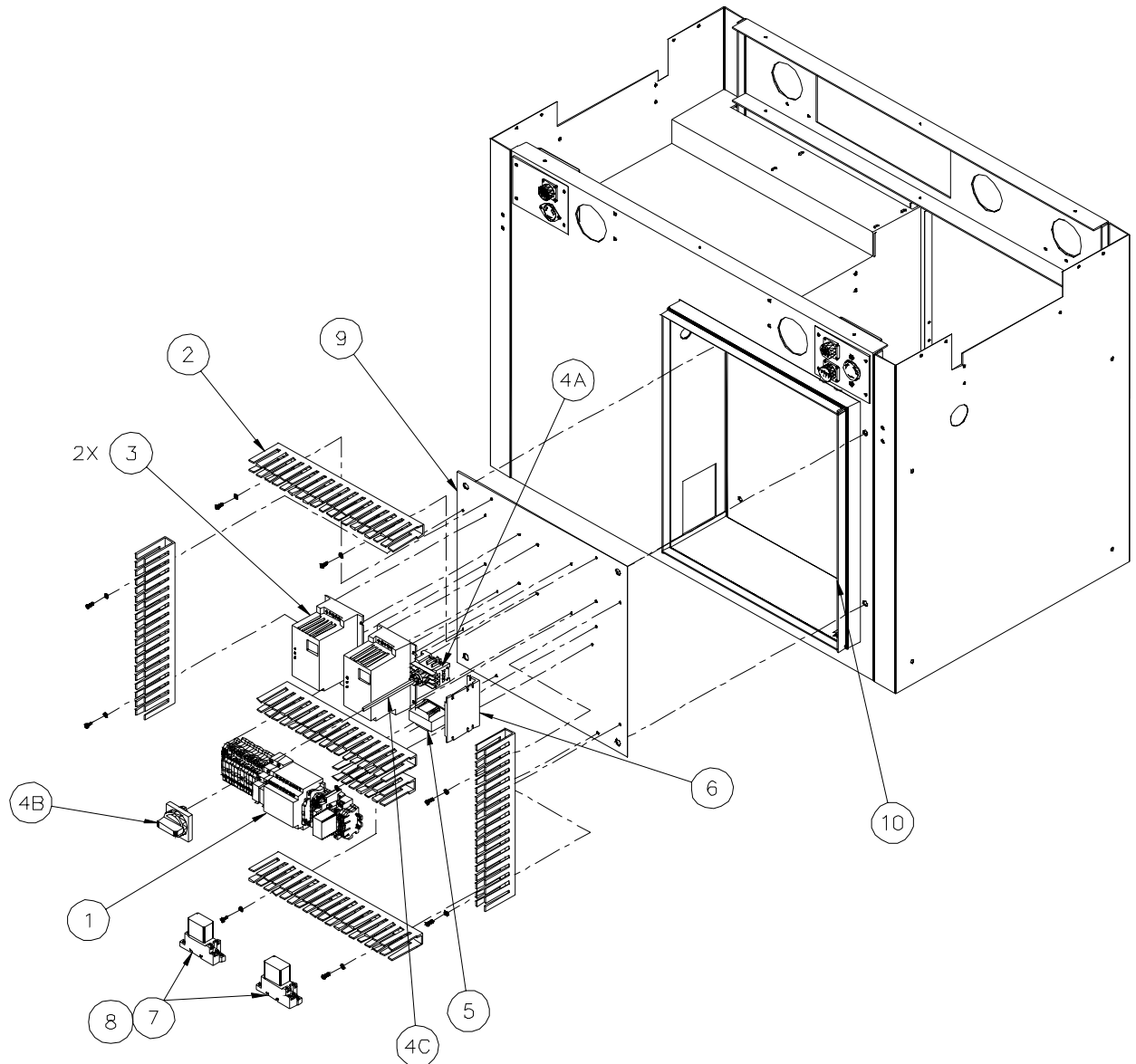

Sure-Feed
Engineering Inc

INK JET SYSTEM - ELECTRICAL (Fig. 19)
DIN RAIL ASSEMBLY

ITEM	PART NO.	QTY.	DESCRIPTION
1	98013-038	1	PLC, FX1s-20MR, MITS.
2	98013-015	1	OPTO ISOLATOR, OFF
3	98002-012	2	SOCKET, SPST RELAY, PRESSURE CLAMP TYPE
4	98002-022	1	RELAY, SPST, 110 VAC
5	98002-011	1	RELAY, SPST, 24 VDC
6	98002-005	1	SOCKET, DPDT RELAY, PRESSURE CLAMP TYPE
7	98002-007	1	RELAY, DPDT, 24 VDC
8	98001-012	13	FUSE, BLOCK, ENTRELEC
9	98001-010	6	TERMINAL BLOCK, ENTRELEC
10	98001-013	3	GROUND TERMINAL, SPRING, ENTRELEC
11	98001-049	3	GROUND TERMINAL, SCREW, ENTRELEC
12	98001-020	2	SIDE COVER, FUSE BLOCK
13	98001-022	12.5"	DIN RAIL, ENTRELEC
14	98004-007	6	FUSE, 3.15 AMP, 225V, 5X20 MM
15	98004-017	3	FUSE, 1 AMP, 225V, 5X20 MM
16	98004-023	2	FUSE, 2 AMP, 225V, 5X20 MM
17	98004-013	2	FUSE, .250 AMP, 225V, 5X20 MM
18	98001-017	2	JUMPER, 3-POLE, TERMAINAL

FIG. 19

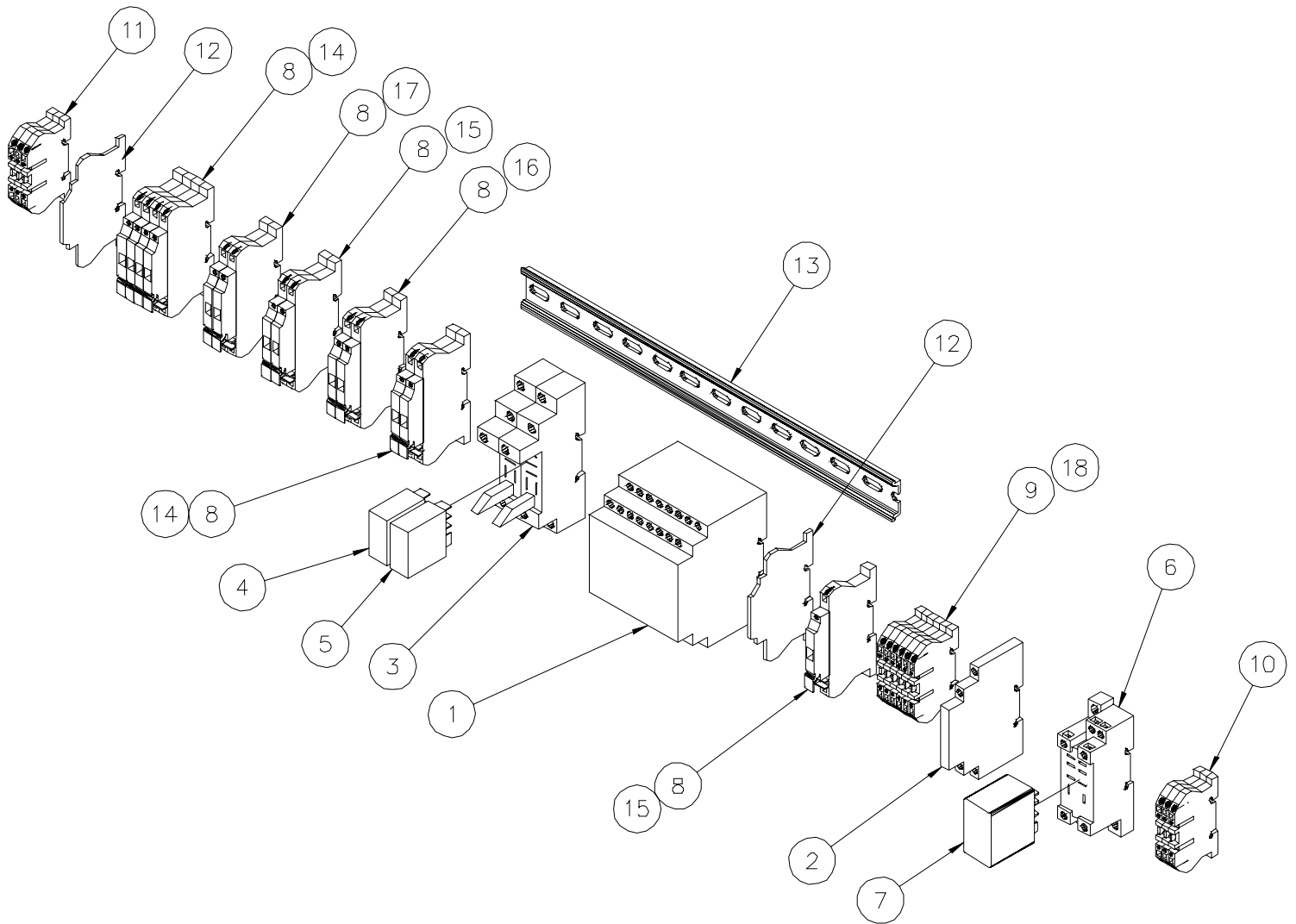

Sure-Feed
Engineering Inc

INK JET SYSTEM - ELECTRICAL (Fig. 20)
RECEPTICAL ASSY

ITEM	PART NO.	QTY.	DESCRIPTION
1	16013-042	1	ENCLOSURE, MAIN, SCITEX INKJET BASE
2	98016-009	1	RECEPTICAL, SQ. FL, AMP, 23-7 REV (FEMALE)
3	98016-011	1	RECEPTICAL, SQ FL, AMP, 11-4 REV (FEMALE)
4	98015-018	1	WIRE CLAMP, STEEL, ROMEX, 3/4"
5	98105-009	6	WIRE CLAMP, STEEL, ROMEX, 3/8"
6	98015-027	2	CORD GRIP, 1/2" (GRAY)

FIG. 20

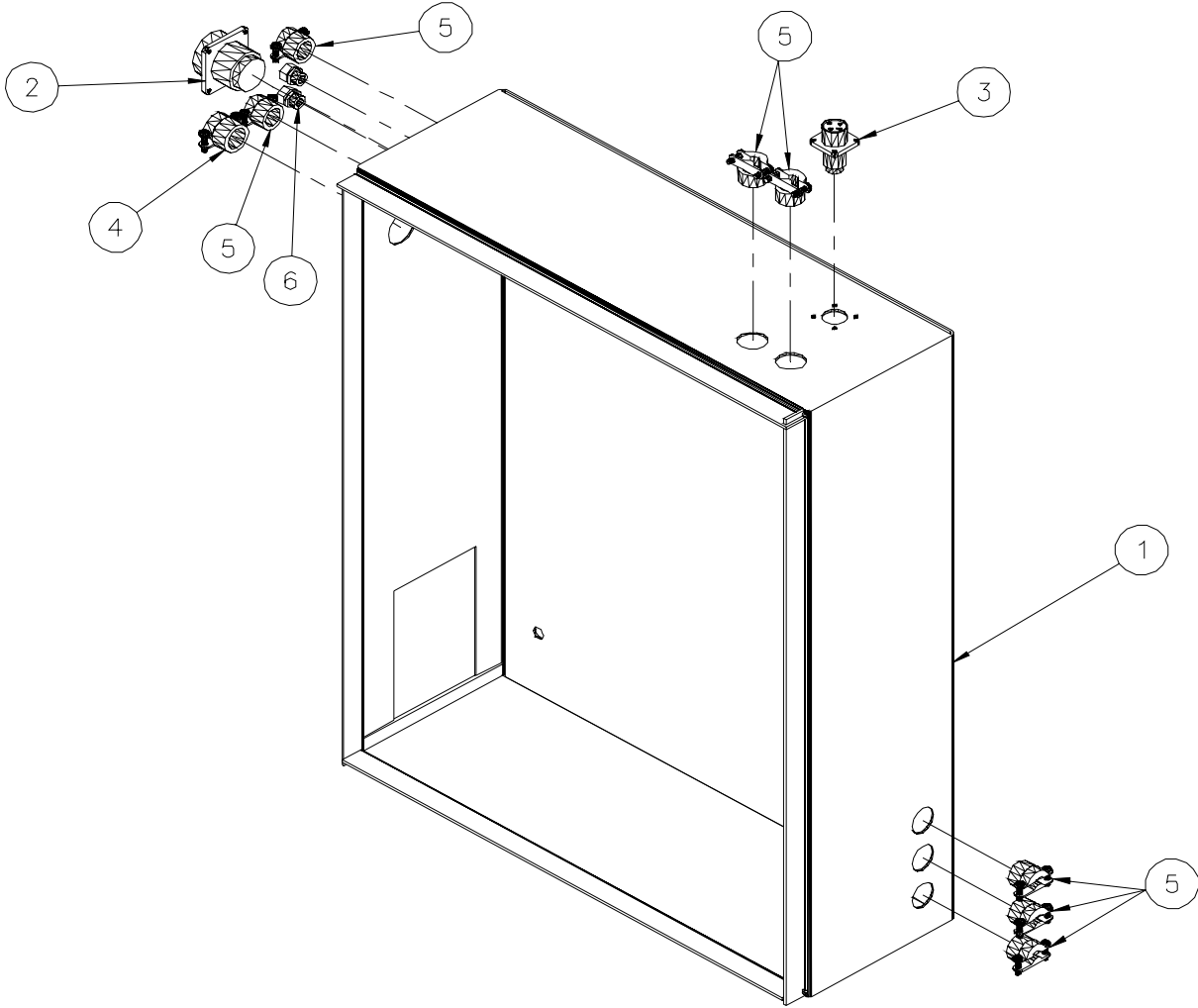

**INK JET SYSTEM - ELECTRICAL (Fig. 21)
 TRANSFORMER ENCLOSURE ASSEMBLY**

ITEM	PART NO.	QTY.	DESCRIPTION
1	16013-039	1	ENCLOSURE, ELECTRICAL TRANSFORMER
2	98008-008	1	TRANSFORMER, 220 VAC 10A / 115 VAC 15A
3	98020-023	1	FILTER, 30 AMP
4	98004-029	1	CIRCUIT BREAKER, 20 AMP, 2 POLE
5	98004-030	1	CIRCUIT BREAKER, 7 AMP, 2 POLE
6	98020-050	1	CABINET FAN, 110 VAC
7	98020-051	1	FAN GAURD
8	98004-002	1	CIRCUIT BREAKER, 1 AMP
9	98015-002	1	STRAIN RELIEF, 3/4"
10	98015-001	2	STRAIN RELIEF, 1/2"
12	98001-022	14.5"	DIN RAIL, ENTRELEC
13	98004-031	1	CIRCUIT BREAKER, 15 AMP
14	98001-028	12	TERMINAL, SCREW IN, 10Ga
15	98001-010	6	TERMINAL BLOCK, ENTRELEC
16	98001-049	2	GROUND TERMINAL, SCREW IN, ENTRELEC
17	98001-058	1	JUMPER, 2-POLE, SCREW IN TERMINAL
18	98001-016	2	JUMPER, 2-POLE, TERMAINAL
19	98015-004	1	LOCKNUT, 3/4"
20	98015-003	2	LOCKNUT, 1/2"

FIG. 21

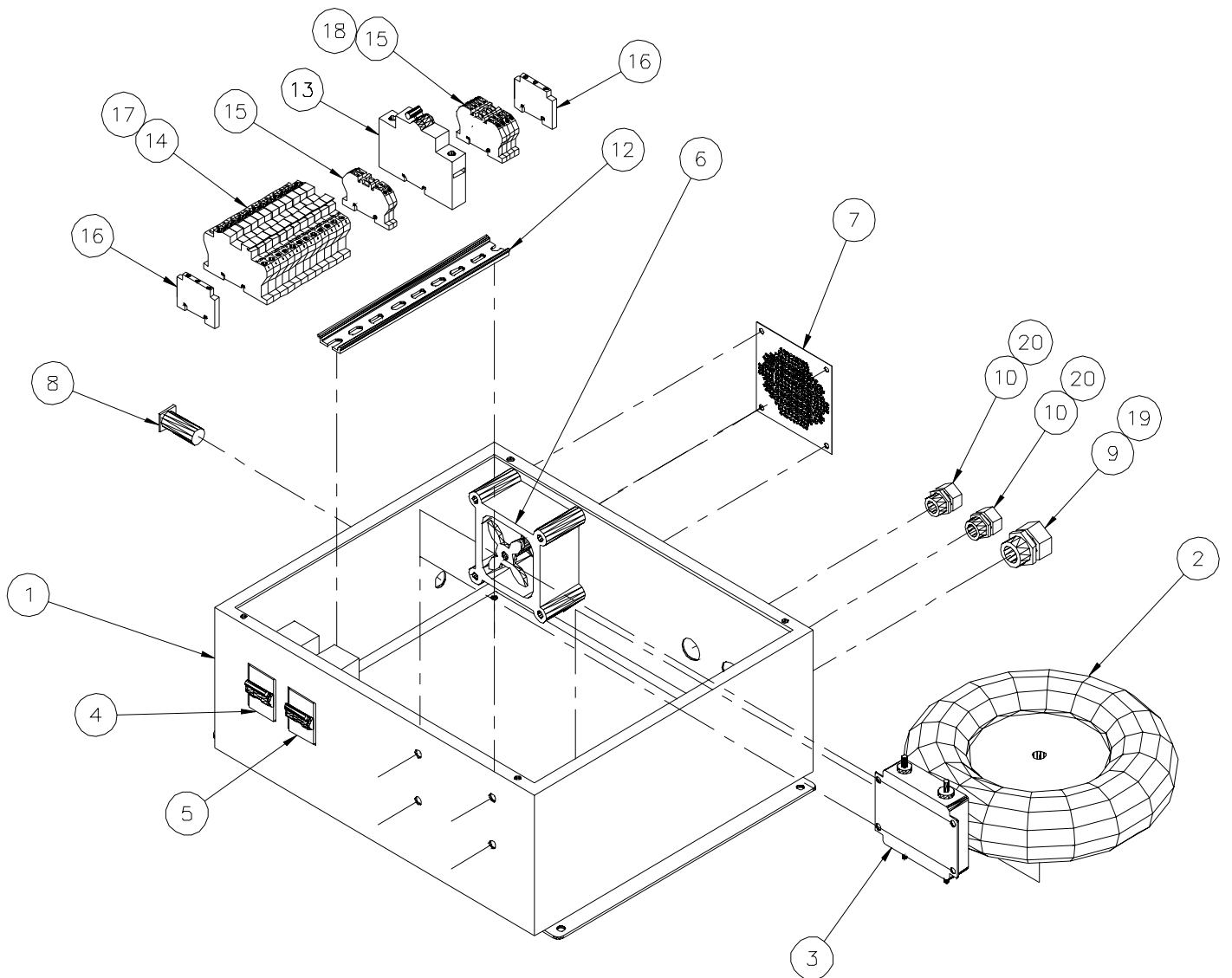

Sure-Feed
Engineering Inc

DRYER BASE - ELECTRICAL (Fig. 22)
DRYER ENCLOSURE ASSEMBLY

ITEM	PART NO.	QTY.	DESCRIPTION
1	SEE FIG. 24	1	DRYER BASE ELECTRICAL ASSEMBLY
2	18013-111	1	ENCLOSURE BOX, DRYER ELECTRICAL
3	98015-002	1	STRAIN RELIEF, 3/4"
4	98015-001	1	STRAIN RELIEF, 1/2"
5	98016-084	1	CONNECTOR, 15 POSITION, FEMALE
6	98020-028	1	RJ45 / RJ45 ADAPTOR
7	98015-022	1	FINISHING PLUG, BLACK PLASTIC, 1-3/4" HOLE
8	98015-011	3	FINISHING PLUG, STEEL, 7/8" HOLE
9	98000-026	1	SWITCH OPERATOR (RED/YELLOW)

Sure-Feed
Engineering Inc

FIG.22

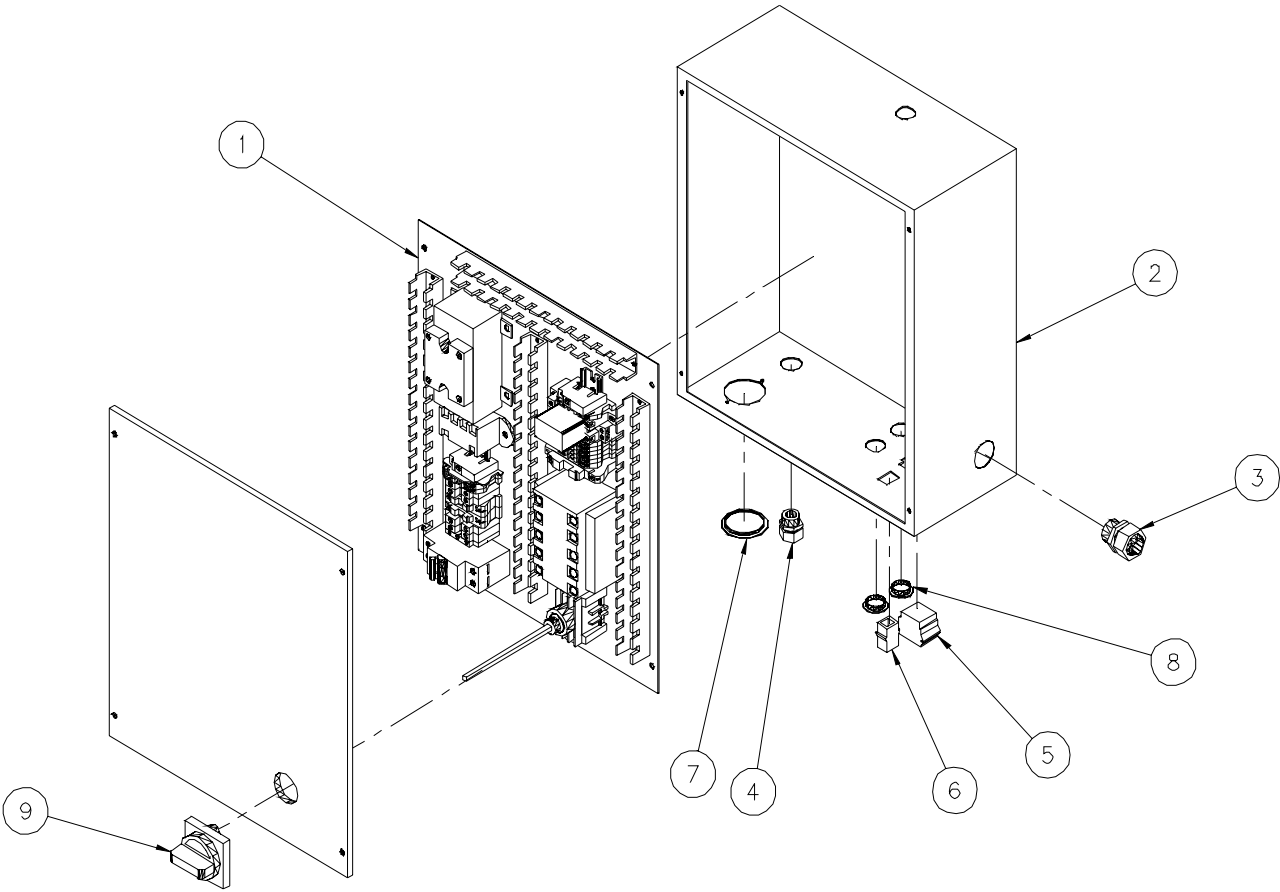

Sure-Feed
Engineering Inc

**DRYER BASE – ELECTRICAL COMPONENTS
ASSEMBLY (Fig. 23)**

ITEM	PART NO.	QTY.	DESCRIPTION
1	98014-007	1	BACK PANEL, ELECTRICAL ENCLOSURE, DRYER
2	98012-004	38"	WIREWAY, 1X1
3	98001-022	18"	DIN RAIL
4	98020-048	1	HEAT SINK
5	98020-049	1	POWER CONTROLLER
6	98002-021	1	RELAY, HIGH POWER, DPST
7	98011-005	1	POWER SUPPLY, 24VDC, 30W
8	98004-014	1	CIRCUIT BREAKER, 30AMP, 2-POLE
9	98001-049	2	TERMINAL, GROUND
10	98001-047	4	TERMIANL STRIP, 70A
11	98001-011	2	FUSE BLOCK, ENTRELEC, 4MM
12	98001-010	9	TERMINAL BLOCK, ENTRELEC
13	98001-014	2	TERMINAL BLOCK, END STOP
14	98001-012	1	FUSE BLOCK (SPRING), ENTRELEC
15	98002-005	1	SOCKET, RELAY, DPDT
16	98002-007	1	RELAY, 24V DC, DPDT
17	98001-026	1	CIRCUIT DIVIDER
18	98001-017	2	JUMPER, 3-POLE
19	98004-017	1	FUSE, 1 AMP, 250V, 5X20MM
20	98004-023	2	FUSE, 2 AMP, 250V, 5X20MM
21	98000-022	1	SWITCH ASSY, POWER DISCONNECT
22	98001-020	1	SIDE COVER, SPRING FUSE

FIG. 23

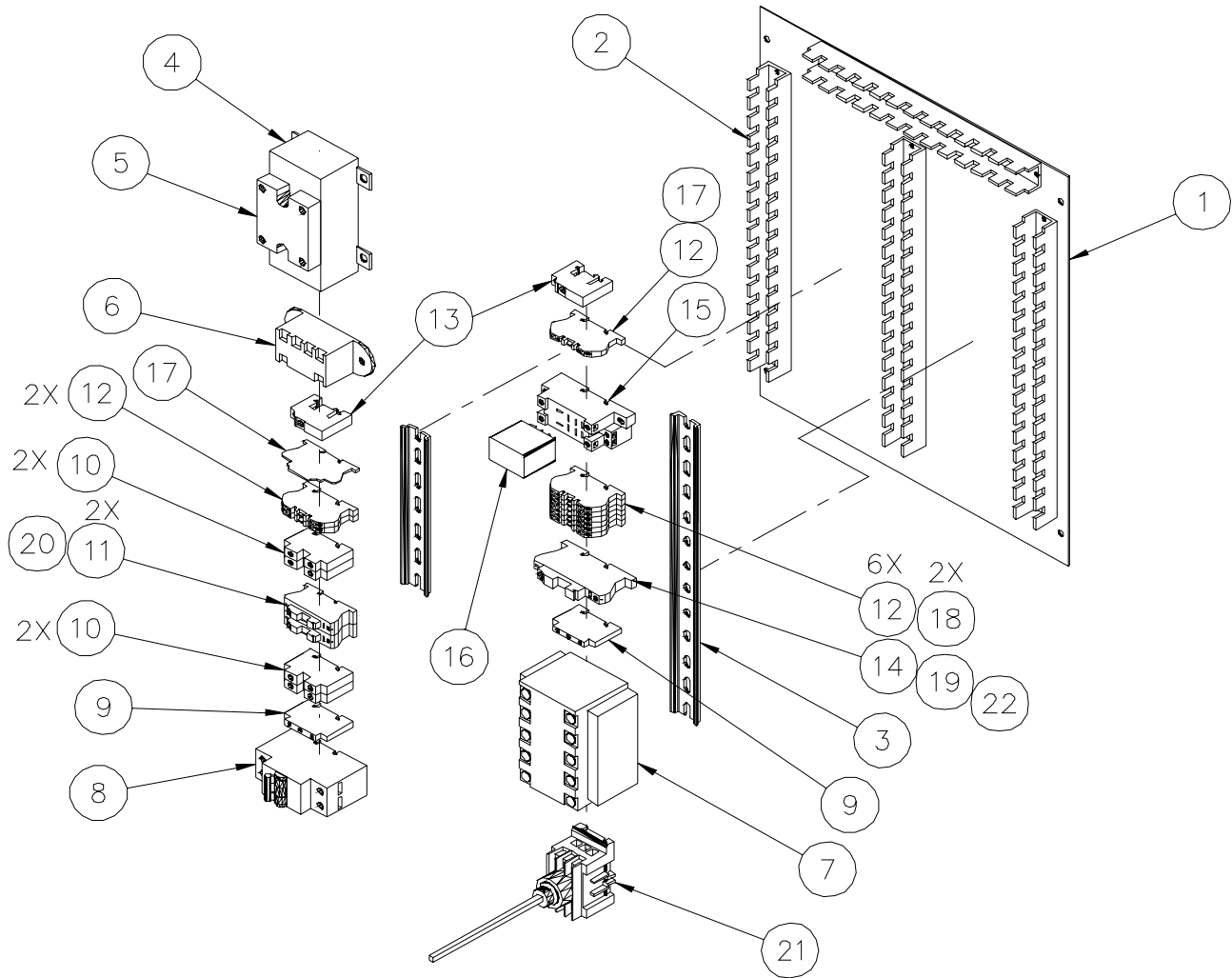

Sure-Feed
Engineering Inc

FEEDER STAND ASSEMBLY (Fig. 24)

ITEM	PART NO.	QTY.	DESCRIPTION
1	SEE FIG. 22	1	BASE ASSEMBLY
2	SEE FIG. 23	1	FEEDER ASSEMBLY
3	19001-003	1	PLATE, TOP, FEEDER STAND (STD)
4	16007-001	2	BLOCK, TOP PLATE MTG.
5		6	SCREW, FLAT HD, 10-24 X 5/8
6		4	SCREW, BUTTON HD, 10-24 X 1/2
7	18012-006	4	STANDOFF, 1/2 X 13/16

FIG. 24

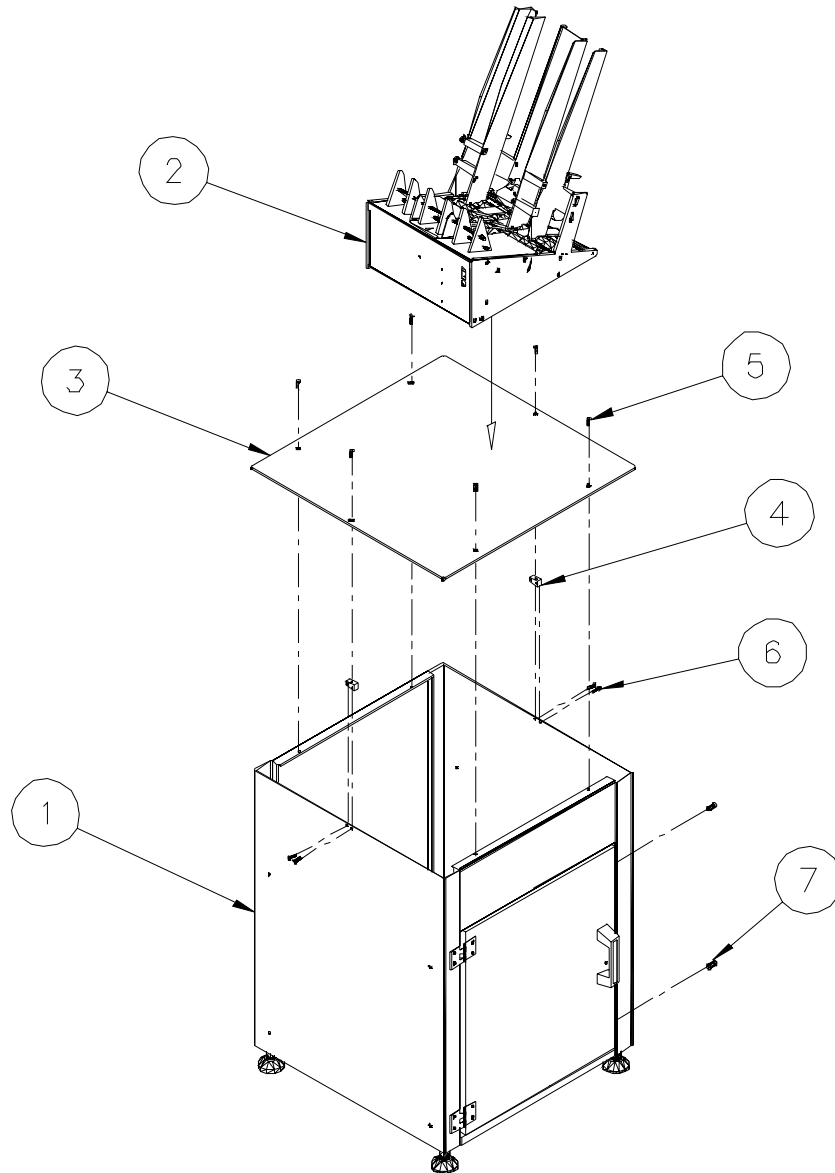

Sure-Feed
Engineering Inc

FEDDER STAND (Fig. 25)
BASE ASSEMBLY

ITEM	PART NO.	QTY.	DESCRIPTION
1	19000-001	1	BASE FRAME WELDMENT, FEEDER STAND, INK JET
2	19013-001	1	DOOR, FRONT
3	99012-001	1	HANDLE, DOOR
4	99011-001	2	HINGE, DOOR
5	99013-001	1	LATCH, DOOR
6	99010-001	4	FOOT, ADJ, 5/8-11
7		8	SCREW, SKT HD, 1/4-20 X 3/4
8	NOT SHOWN	4	NUT, JAM, 5/8-11 (ADJ. FOOT)
9	NOT SHOWN	8	WASHER, FLAT, 1/4 (DOOR HINGE)
10	NOT SHOWN	8	NUT, HEX, 1/4 (DOOR HINGE)

FIG. 25

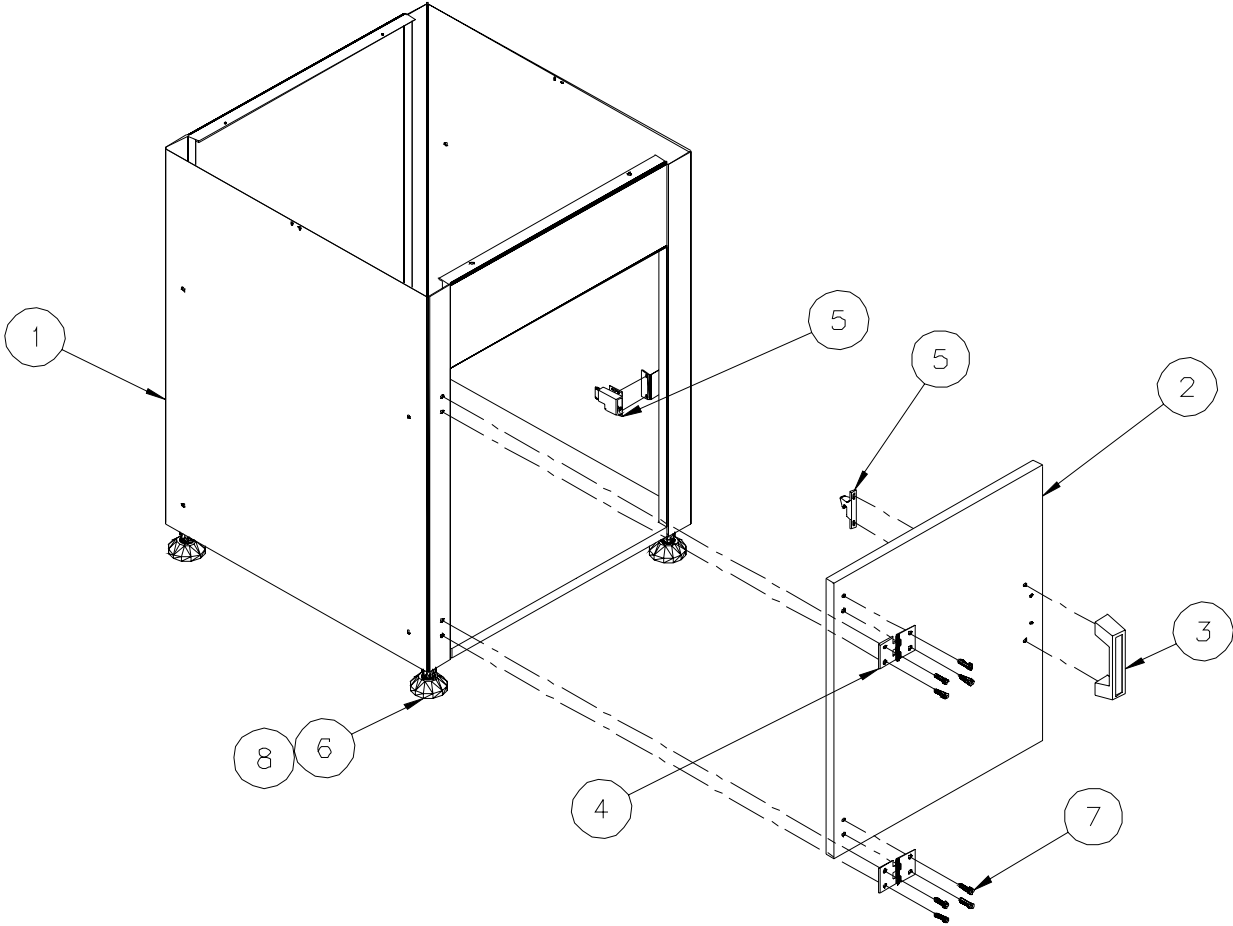

Sure-Feed
Engineering Inc

SJ30 FEEDER ASSEMBLY (Fig. 26)

ITEM	PART NO.	QTY.	DESCRIPTION
1	99000-001	1	BELT, TIMING 90XL
2	99000-002	1	BELT, TIMING 110XL
3	99000-003	1	BELT, TIMING 120XL
4	99000-004	3	BELT, RED GUM
5	99000-005	2	BELT, ELEVATOR
6	SEE FIG. 27	1	SEPERATOR DEVICE ASSEMBLY
7	SEE FIG. 28	1	SIDE GUIDE ASSEMBLY
8	SEE FIG. 29	1	FRONT SHAFT ASSEMBLY
9	SEE FIG. 29	1	NIP ROLLER SHAFT ASSEMBLY
10	SEE FIG. 29	1	SUPPORT IDLER SHAFT ASSEMBLY
11	SEE FIG. 30	1	MAIN SHAFT ASSEMBLY
12	SEE FIG. 30	1	JACK SHAFT ASSEMBLY
13	SEE FIG. 30	1	ELEVATOR SHAFT ASSEMBLY
14	SEE FIG. 31	1	PAPER SLIDE ASSEMBLY
15	SEE FIG. 32	1	MOTOR ASSEMBLY
16	SEE FIG. 32	1	CHASSIS / ELECTRICAL ASSEMBLY
17	SEE FIG. 33	1	TRAILING ARM ASSEMBLY

FIG. 26

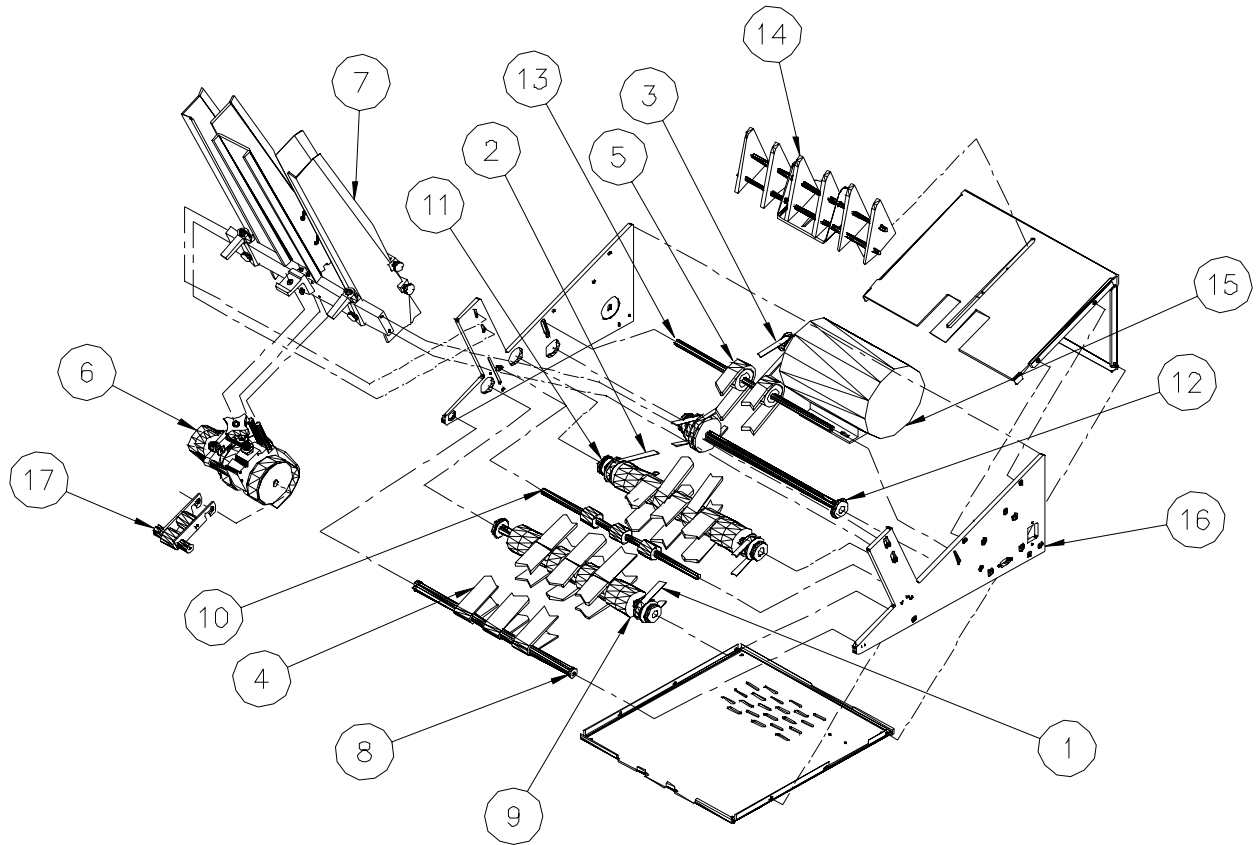

Sure-Feed
Engineering Inc

SEPARATOR DEVICE ASSEMBLY (ECO-SERIES) (Fig. 27)

ITEM	PART NO.	QTY.	DESCRIPTION
1	10007-002	1	BLOCK, FOOTBALL SEPARATOR
2	10004-059	1	SHAFT, FOOTBALL ALIGNING
3	10004-058	1	SHAFT, FOOTBALL SEPARATOR
4	10005-025	1	SHROUD, SEPARATOR
5	10007-005	2	BLOCK, FOOTBALL.
6	10007-012	1	BLOCK, SEPARATOR ADJUSTING
7	10004-028	1	STUD, SEPARATOR ADJUSTING
8	99004-001	1	KNOB 5/16-24 FE
9	10014-001	2	BELT, SEPARATOR, 3"
10	99005-001	1	SPRING, .068 X .48 X 1-7/16"
11	10012-005	2	SPACER, FOOTBALL SEPERATOR
12		1	NUT, HEX 5/16-24
13		2	WASHER, FLAT 5/16
14		2	SCREW, PAN HD 10-24 X 3/8
15		3	SCREW, FL HD 8-32 X 1
16		2	WASHER, FLAT, #10
17	99003-017	2	WASHER, NYLON 3/8 ID X 1/16
18	99022-003	2	SNAP RING, 3/8
19		2	BOLT, SOCKET HD, 5/16-18 X 2 1/2
20	99003-015	1	WASHER, NYLON, 5/16 X 1/16

FIG. 27

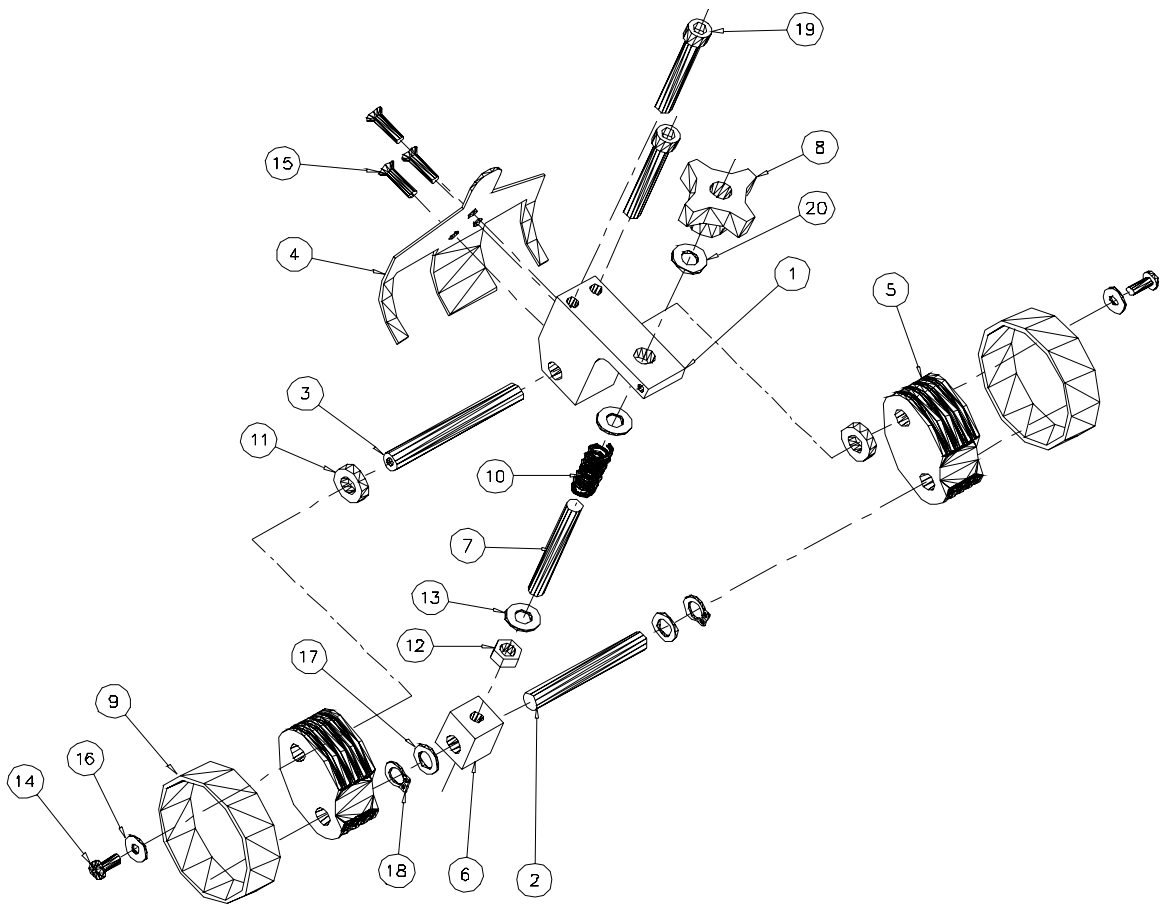

Sure-Feed
Engineering Inc

SIDE GUIDE ASSEMBLY (Fig. 28)

ITEM	PART NO.	QTY.	DESCRIPTION
1	10009-002	2	BRACKET, SIDE GUIDE MTG
2	10003-002	1	CROSS BAR, SE-1200-IJ & P
3	10005-009	1	GUIDE, SIDE RH (TALL) SE-1200
4	10005-002	1	GUIDE, FRONT PAPER (TALL)
5	10005-008	1	GUIDE, SIDE, LH (TALL) SE-1200
6	10005-014	1	GUIDE, BUSINESS RH (TALL) SE-1200
7	10007-008	4	BLOCK, BUSINESS GUIDE MTG.
8	10005-015	1	GUIDE, BUSINESS, LH (TALL) 1200
9	99004-002	6	KNOB, #10 SCREW
10		8	SCREW, SKT HD 10-24 X 1/2
11		4	SCREW, BTN HD 10-24 X 1/2
12		4	SCREW FL HD 10-24 X 3/8
13		8	SCREW FL HD 8/32 X 1/2
14		4	SCREW FL HD 6/32 X 1/2
15	10007-010	1	BLOCK, SEPARATOR ADJUSTING
16	99004-003	2	HANDLE, RATCHET, 10-24

FIG. 28

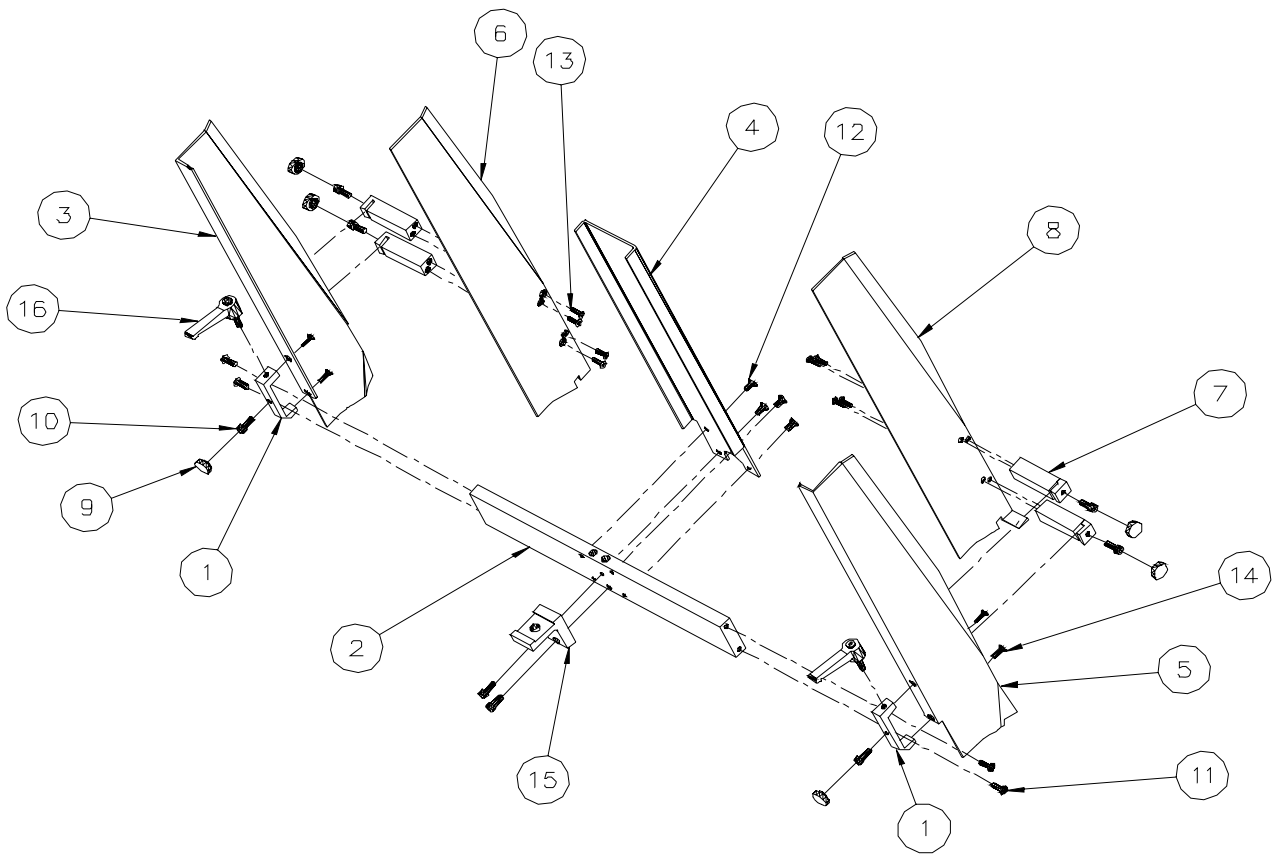

Sure-Feed
Engineering Inc

**FRONT SHAFT, NIP ROLLER SHAFT, AND
 SUPPORT SHAFT ASSEMBLY (Fig. 29)**

ITEM	PART NO.	QTY.	DESCRIPTION
1	10004-024	1	SHAFT, FRONT SE-1200-P & IJ
2	10004-022	1	SHAFT, NIP ROLLER SE-1200-P & IJ
3	10004-023	1	SHAFT, SUPPORT IDLER SE-1200-P & IJ
4	10006-013	2	NIP ROLLER
5	10006-015	3	PULLEY, MATE
6	10006-007	4	FEEDER ROLL
7	99002-003	1	PULLEY, 20XL037
8	10006-012	3	ROLLER, IDLER
9	99003-003	2	BEARING, 1/2" ID X 1-1/8" OD W/GROOVE
10	99003-001	6	BEARING, 3/8 ID X 7/8 OD
11	99003-002	2	BEARING, 1/4" ID X 5/8" OD SEALED
12	99022-004	2	RETAINING RING 1/2
13	99022-003	6	RETAINING RING 3/8
14		10	SCREW, SET 10-24 X 3/8
15		2	SCREW, BTN HD 10-24 X 1/2
16		2	SCREW, SET 8/32 X 3/8

FIG. 29

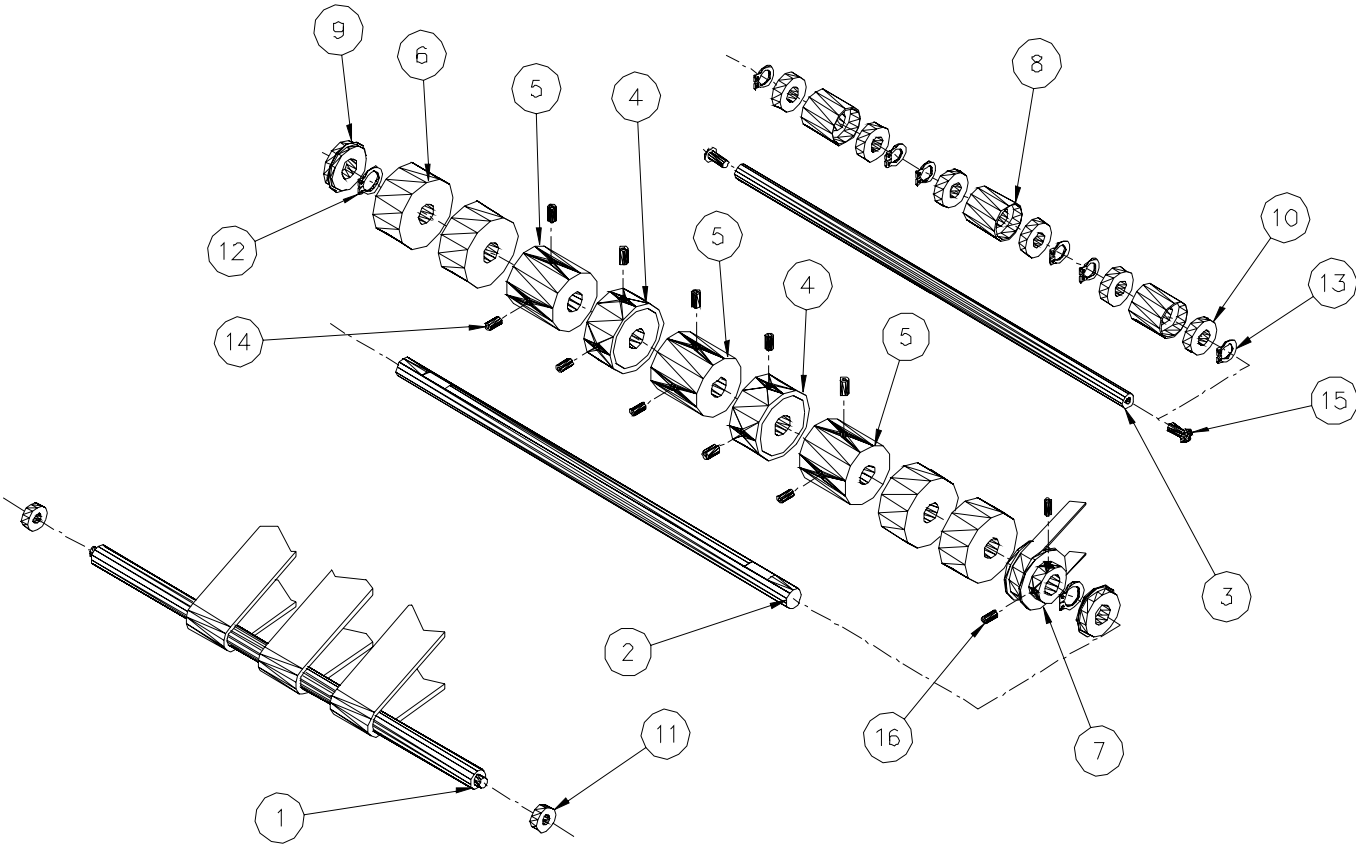

Sure-Feed
Engineering Inc

**MAIN SHAFT, JACK SHAFT, AND ELEVATOR SHAFT
ASSEMBLY (Fig. 30)**

ITEM	PART NO.	QTY.	DESCRIPTION
1	10004-022	2	SHAFT, NIP ROLLER SE-1200-P & IJ
2	10004-023	1	SHAFT, SUPPORT IDLER SE-1200-P & IJ
3	10006-018	3	PULLEY, CROWNED (GUM BELT DRIVE)
4	10006-007	4	FEEDER ROLL
5	10006-022	2	PULLEY, IDLER 24XL875
6	10006-021	2	PULLEY, DRIVE 22XL875
7	99002-003	1	PULLEY, 20XL037
8	99002-004	1	PULLEY, 22XL037
9	99002-006	1	PULLEY, 24XL037
10	99002-005	1	PULLEY, 36XL037
11	99003-003	4	BEARING, 1/2" ID X 1-1/8" OD W/GROOVE
12	99003-001	4	BEARING, 3/8 ID X 7/8 OD
13	99022-004	4	SNAP RING, 1/2
14	99022-003	4	SNAP RING, 3/8
15	99004-002	2	KNOB, #10 SCREW
16	99003-018	1	WASHER, NYLON, 1/2 X 1/16
17		2	SCREW, SKT HD 10-24 X 1/2
18		2	SCREW, SET 1/4-20 X 3/8
19		10	SCREW, SET 10-24 X 3/8
20		6	SCREW, SET 8/32 X 3/8
21		2	WASHER, FLAT, #10

FIG. 30

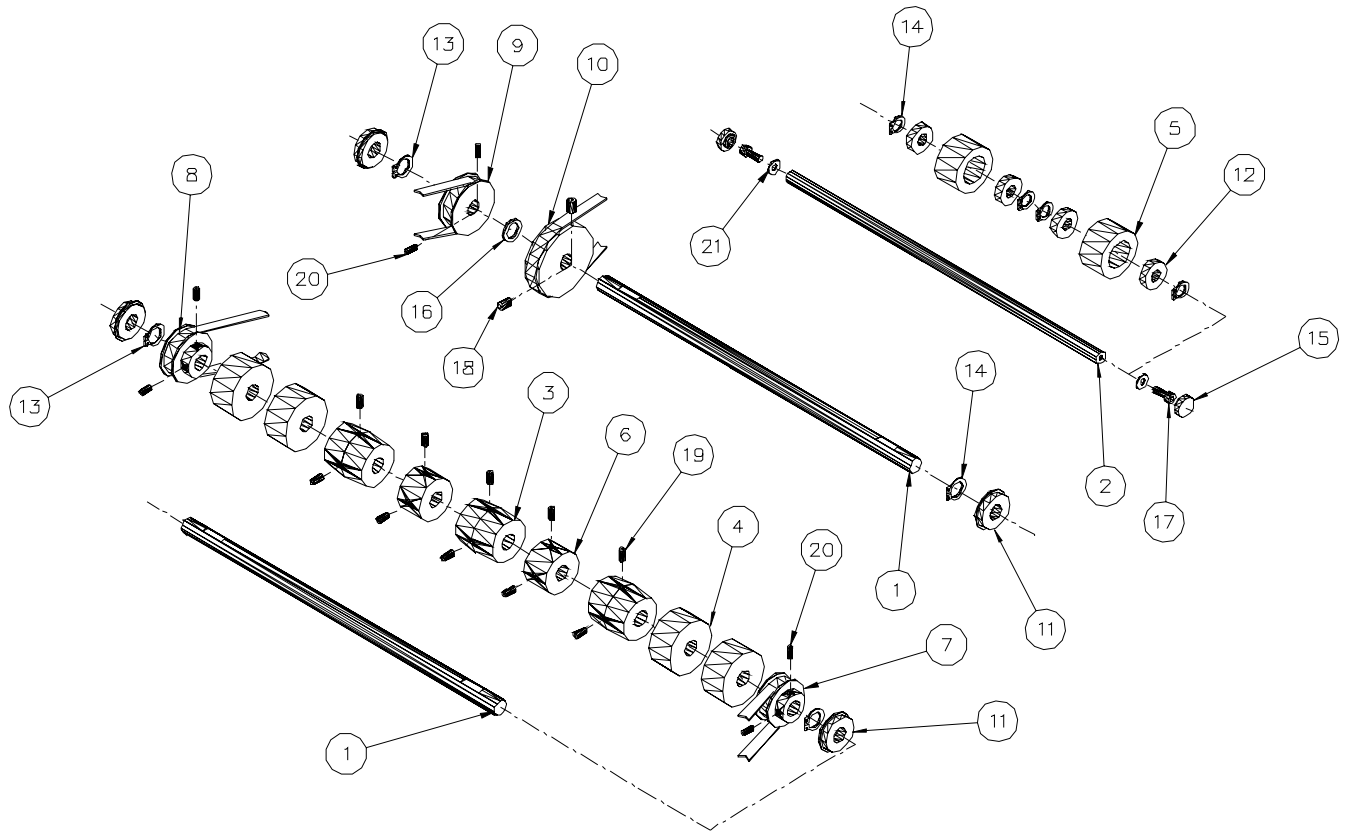

Sure-Feed
Engineering Inc

PAPER SLIDE ASSEMBLY (Fig. 31)

ITEM	PART NO.	QTY.	DESCRIPTION
1	10009-003	1	BRACKET, PAPER SLIDE
2	10004-006	2	SHAFT, PAPER SLIDE SE-1200
3	10005-016	6	SLIDE, PAPER
4	99022-001	8	RETAINING RING, 1/4"
5	99004-002	1	KNOB, #10 SCREW
6		1	SCREW, SKT HD, 10-24 X 1/2
7	10007-003	1	NUT, PAPER SLIDE
8	10007-004	1	WASHER, PAPER SLIDE
9	99006-020	1	PIN, ROLL, 5/32 X 3/4
10		1	WASHER, FLAT, #6

FIG. 31

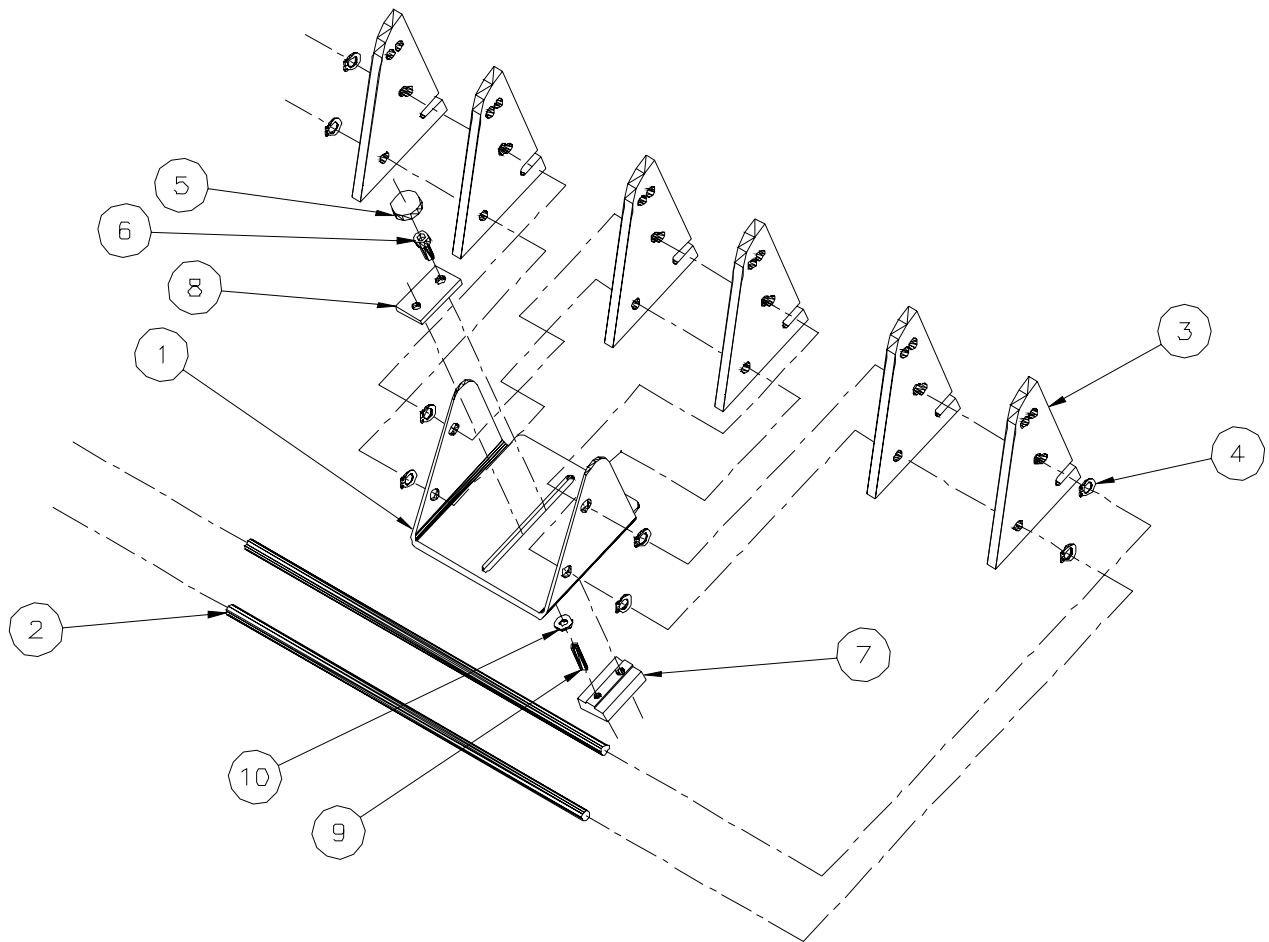

Sure-Feed
Engineering Inc

MOTOR / CHASSIS / ELECTRICAL ASSEMBLY (Fig. 32)

ITEM	PART NO.	QTY.	DESCRIPTION
1	10000-003	1	SIDE FRAME, RH SE-1200-IJ
2	10000-004	1	SIDE FRAME, LH SE-1200-IJ
3	10001-003	1	COVER, TOP
4	10002-002	1	PLATE, BOTTOM
5	99001-012	1	MOTOR, 1/6 HP, 42 FRAME
6	99002-007	1	PULLEY, MOTOR 16XL037
7	99007-001	4	SUCTION CUP, FOOT
8	98016-045	1	RECEPTICAL, SQ FL, AMP SERIES 3, 23-7 STD.
9	98000-016	1	SWITCH, PUSH / PULL, STOP
10	98000-017	1	CONTACT BLOCK ASSY, 1 X CLIP + 1 X NO + 1 X NC
11		4	SCREW, HEX HD, 1/4-20 X 3/4
12		10	SCREW, BTN HD 10-24 X 1/4
13		8	WASHER, LOCK, 1/4
14		10	NUT, PEM 10-24
15		4	NUT, HEX 8-32
16		4	WASHER, FLAT (SAE), 1/4
17		4	WASHER, LOCK #8
18	99003-050	1	BUSHING, 3/8 X 1/2 X 3/4
19	NOT SHOWN	4	NUT, HEX, 1/4-20 (MOTOR MTG.)
20	98007-002	1	CORD, INTERCONNECT, SJ30
21	98016-033	1	PLUG, AMP, SERIES 3, 23-7 STD (CONNECTS TO FEEDER – SJ30)
22	98016-013	1	PLUG, AMP, SERIES 3, 23-7 REV. (CONNECTS TO INK JET SYSTEM)
23	98016-014	2	BACKSHELL, PLASTIC, SIZE 23

FIG. 32

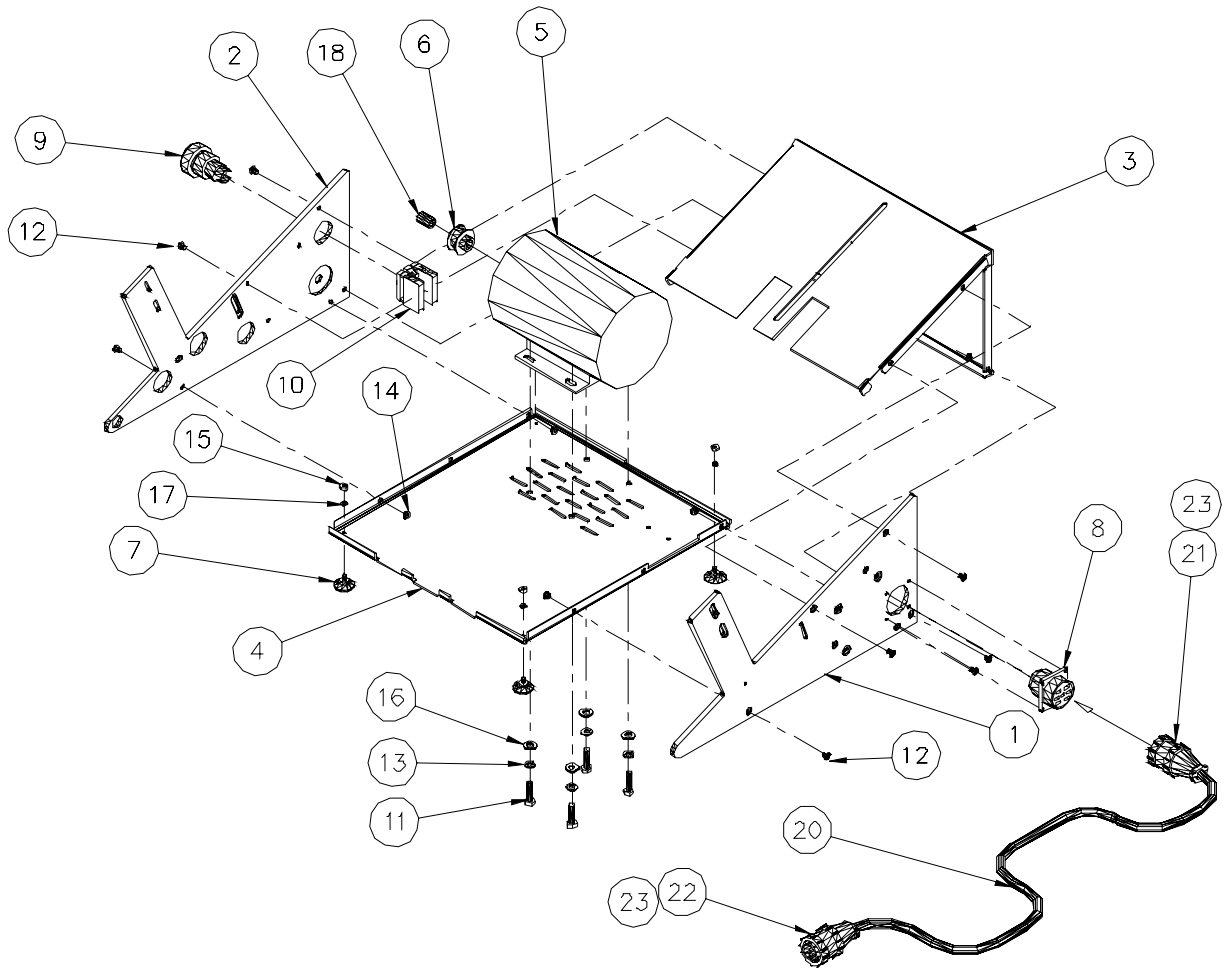

Sure-Feed
Engineering Inc

TRAILING ARM ASSEMBLY (Fig. 33)

ITEM	PART NO.	QTY.	DESCRIPTION
1	10011-002	2	ARM, TRAILER
2	10012-003	2	SPACER
3	10006-016	2	ROLLER
4	10004-007	2	WEIGHT
5		2	SCREW, PAN HD, 8-32 X 1 1/4
6		2	SCREW, PAN HD, 8-32 X 3/8
7		4	WASHER, LOCK INT. TOOTH #8

FIG. 33

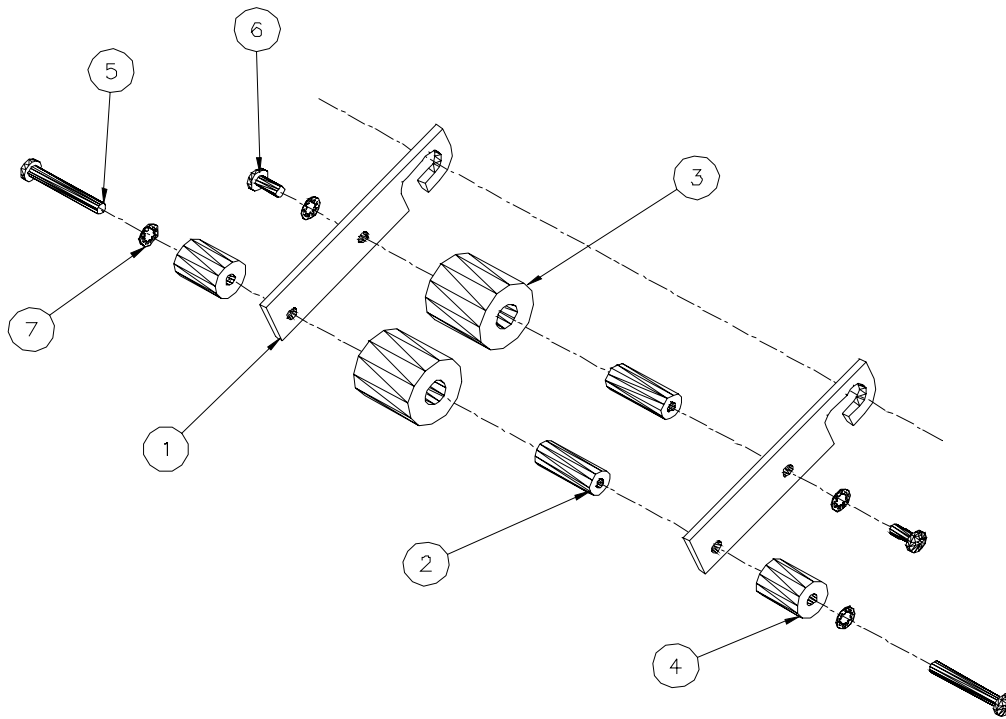

Sure-Feed
Engineering Inc

SPEED UP CONVEYOR ASSEMBLY (Fig. 34)

ITEM	PART NO.	QTY.	DESCRIPTION
1	(SEE FIG. 35)	1	DRIVE SHAFT / MOTOR ASSEMBLY
2	(SEE FIG. 36)	1	IDLER SHAFT ASSEMBLY
3	(SEE FIG. 37)	1	KNOCK DOWN PLATE ASSEMBLY
4	12000-007	1	SIDE FRAME, 9' CONVEYOR
5	12010-004	1	LEG, DRIVE, 30"
6	12010-003	1	LEG, IDLE, 30"
7	12011-006	2	END CAP, IDLE
8	99000-052	3	BELT, ENDLESS, 18' - 1" X 2" W
9	99004-011	2	KNOB, MALE, 10-32 X 3/4
10	99010-001	4	FOOT, ADJUSTING
11		24	SCREW, BUTTON HD, 1/4-20 X 1/2
12		4	SCREW, BUTTON HD, 1/4-20 X 3/4
13		12	WASHER, FLAT, 1/4
14		4	NUT, HEX HD, 5/8-11
15	98015-001	1	STRAIN RELIEF, 1/2
16	98015-003	1	LOCKNUT, 1/2
17	98016-003	1	PLUG, AMP, SERIES 3, 17-3 STD
18	98016-005	1	BACKSHELL, PLASTIC, SIZE 17

FIG. 34

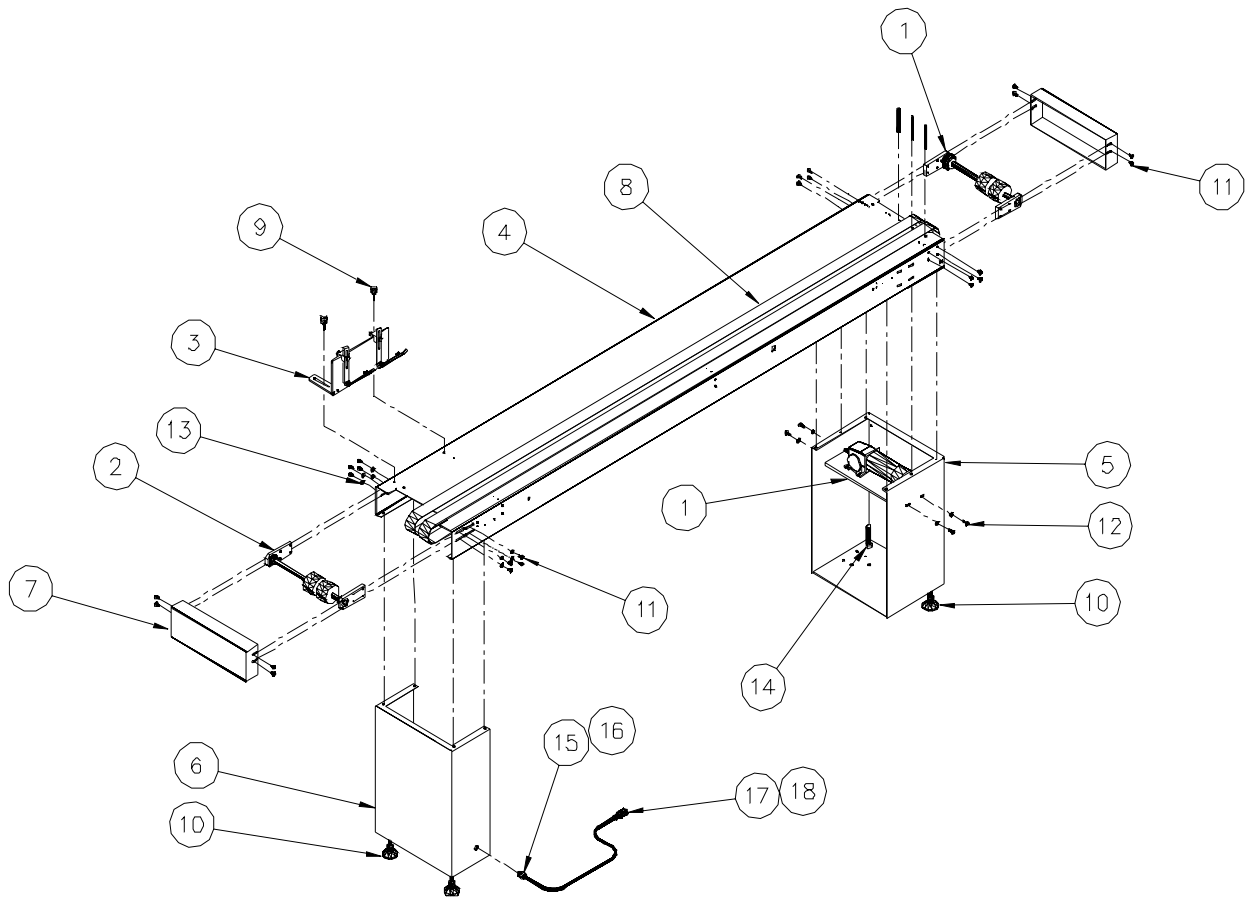

Sure-Feed
Engineering Inc

SPEED UP CONVEYOR (Fig. 35)
DRIVE SHAFT / MOTOR ASSEMBLY

ITEM	PART NO.	QTY.	DESCRIPTION
1	12004-003	1	SHAFT, DRIVE, CONVEYOR
2	12007-001	2	BLOCK, BEARING
3	12011-005	1	PLATE, MOTOR MTG.
4	99001-014	1	MOTOR, 1/8 HP, 167 RPM, 90V DC
5	12006-002	2	PULLEY, CROWNED, 2" WIDE
6	99002-047	1	PULLEY, 20L050, 5/8 BORE
7	99002-041	1	PULLEY, 14L050, 5/8 BORE W/ HUB
8	99000-063	1	BELT, 210L050
9	99003-006	2	BEARING, SEALED, 5/8 X 1-3/8
10	99017-005	1	COLLAR, SET, 5/8
11	99003-021	1	WASHER, NYLON, 5/8 X 1/16
12		4	SCREW, SET, 10-32 X 1

FIG. 35

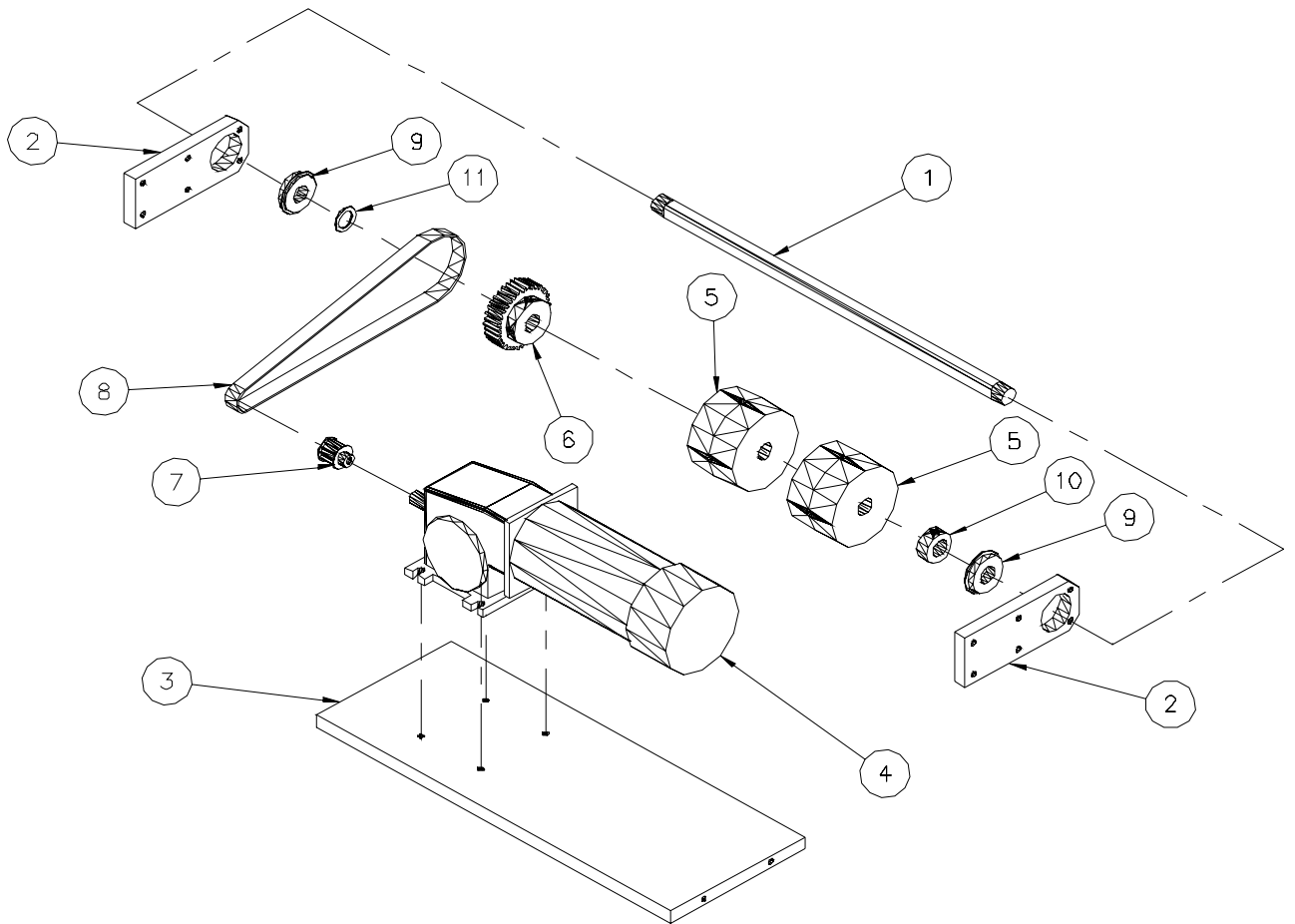

Sure-Feed
Engineering Inc

SPEED UP CONVEYOR (Fig. 36)
IDLER SHAFT ASSEMBLY

ITEM	PART NO.	QTY.	DESCRIPTION
1	12004-003	1	SHAFT, DRIVE, CONVEYOR
2	12007-001	2	BLOCK, BEARING
3	12006-002	2	PULLEY, CROWNED, 2" WIDE
4	12007-002	2	BLOCK, TENSIONER
5	99003-006	2	BEARING, SEALED, 5/8 X 1-3/8
6	99017-005	2	COLLAR, SET, 5/8
7		2	SCREW, HEX HD, 1/4-20 X 3 (ALL THREAD)
8		2	NUT, HEX, 1/4-20

FIG. 36

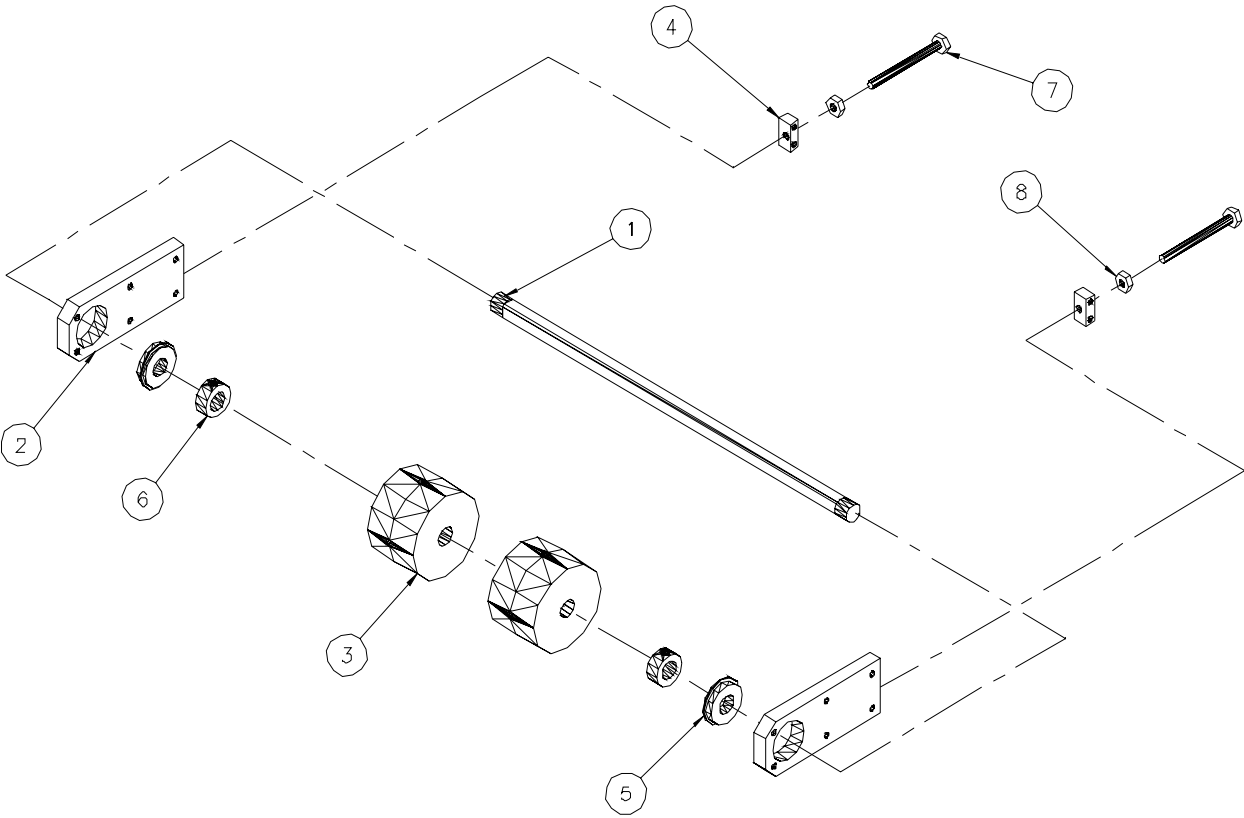

Sure-Feed
Engineering Inc

SPEED UP CONVEYOR (Fig. 37)
KNOCK DOWN PLATE ASSEMBLY

ITEM	PART NO.	QTY.	DESCRIPTION
1	12011-007	1	PLATE, KNOCK DOWN
2	12007-006	2	BAR, PLATE MTG.
3	12008-001	2	BRACKET, KNOCK DOWN
4	12007-007	2	BRACKET, KNOCK DOWN MTG.
5	12005-007	2	STRAP, KNOCK DOWN
6	99004-002	6	KNOB, #10 SCREW
7		4	SCREW, SKT HD, 10-24 X 1/2
8		4	SCREW, BUTTON HD, 10-24 X 1/4

FIG. 37

