

# ***INSERTER 5' SHINGLING CONVEYOR***

***Parts Manual***



SURE-FEED ENGINEERING, INC.

12050 49th Street North Clearwater, Florida 33762-4301

PHONE: 727.571.3330 FAX: 727.571.3443

e-mail: [sales@sure-feed.com](mailto:sales@sure-feed.com)

***TABLE OF CONTENTS***

**5' INSERTER SHINGLING CONVEYOR**

FRAME ASSEMBLY (FIGURE 1).....3  
CONVEYOR BED ASSEMBLY (FIGURE 2).....4  
KNOCK DOWN ASSEMBLY (FIGURE 3).....5  
ELECTRICAL ASSEMBLY (FIGURE 4).....6

FIGURE 3

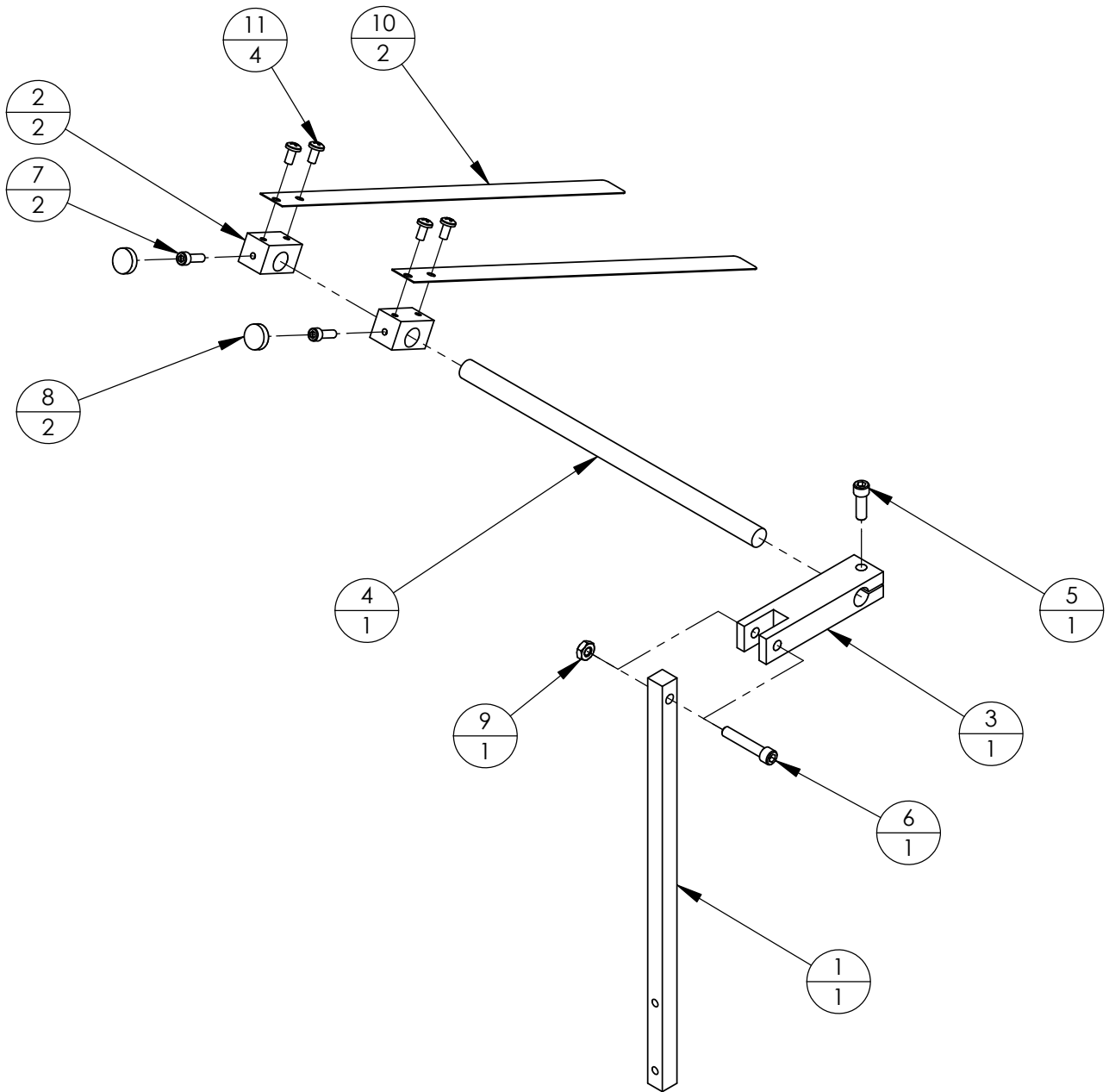

11	-	SCREW, PAN HEAD, #10-24 X 3/8	4
10	12005-011	GUIDE, KNOCKDOWN	2
9	-	NUT, HEX, 1/-40	1
8	99004-002	KNOB, #10 SCREW	2
7	-	SCREW, SKT HD, #10-24 X 5/8	2
6	-	SCREW, SKT HD, 1/4-20 X 1-3/8	1
5	-	SCREW, SKT HD, 1/4-20 X 3/4	1
4	12004-011	SHAFT, KNOCKDOWN MTG.	1
3	12008-003	BAR, KNOCK DOWN MTG.	1
2	12007-015	BLOCK, KNOCKDOWN STRAP MTG.	2
1	12008-002	BAR, KOCK DOWN SUPPORT	1
ITEM NO.	PART NUMBER	DESCRIPTION	QTY

FIGURE 2

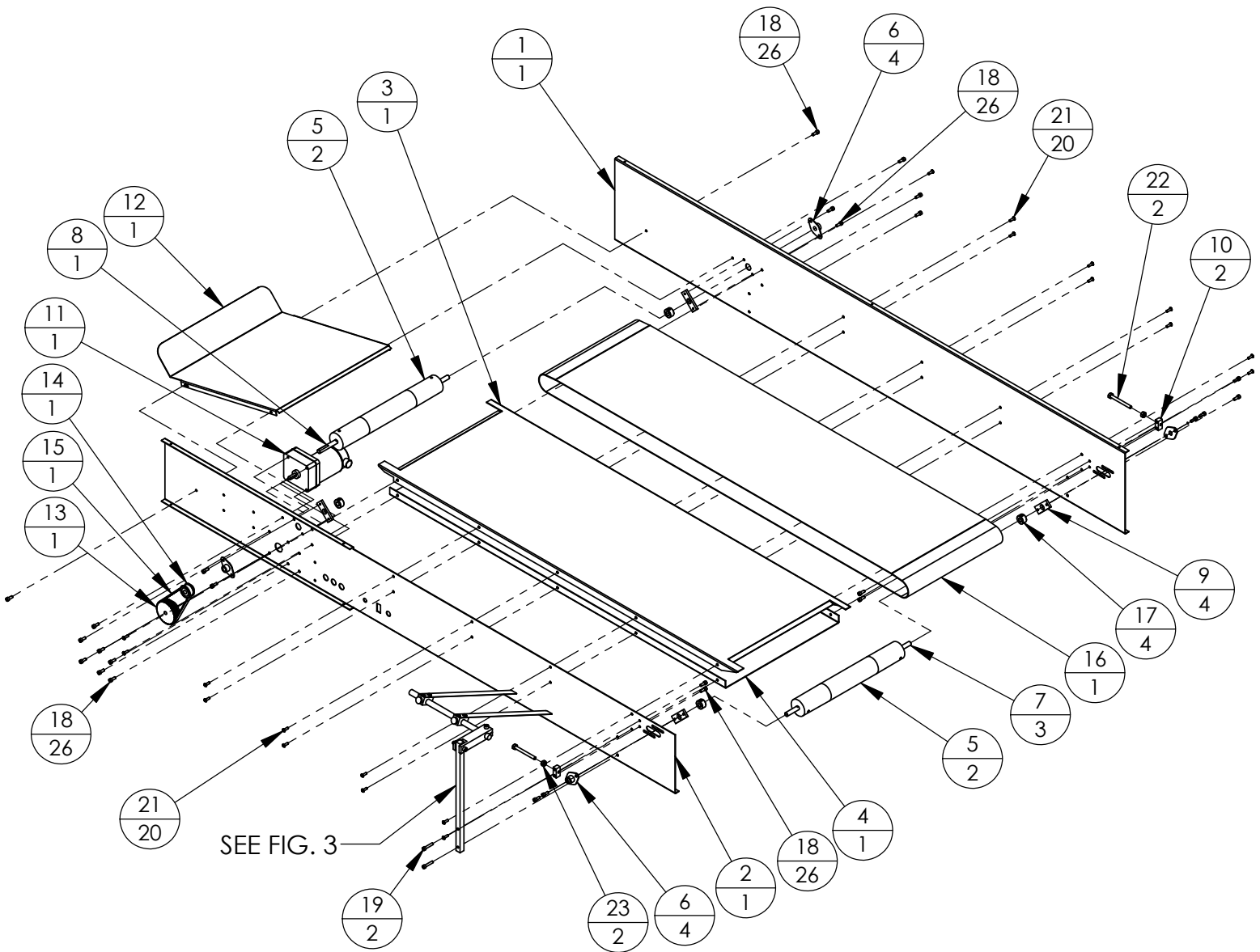

23	-	NUT, HEX, 1/4-20	2
22	-	BOLT, HEX HD, 1/4-20 X 2-1/2	2
21	-	RIVIT, 3/16"	20
20	-	HEX NUT, #10-24	4
19	-	SCREW, SKT HD, #10-24 X 1	2
18	-	SCREW, SKT HEAD, #10-24 X 1/2	26
17	99017-003	COLLAR, 3/8 SHAFT	4
16	99000-014	BELT, 12"W X 96" L (W/ LACING)	1
15	99000-056	BELT, TIMNG, 140XL037	1
14	99002-038	PULLEY, TIMING, 16XL037-3/8B	1
13	99002-039	PULLEY, TIMING, 36XL037, 5/16 B	1
12	12005-001	CATCH PAN	1
11	99001-009	MOTOR, 1/30 HP, 32 RPM	1
10	12007-003	BLOCK, TENSIONER	2
9	12011-001	PLATE, NUT, BEARING ADJ.	4
8	12004-002	SHAFT, STUB DRIVE	1
7	12004-001	SHAFT, STUB	3
6	99003-042	BUSHING, 2 BOLT FLG, 3/8" B	4
5	12006-006	PULLEY, CROWNED, 1-3/4" O.D.	2
4	12002-001	RETURN BED	1
3	12001-001	SLIDER BED	1
2	12000-002	SIDEFAME, LH	1
1	12000-001	SIDEFAME, RH	1
ITEM NO.	PART NUMBER	DESCRIPTION	QTY

FIGURE 1

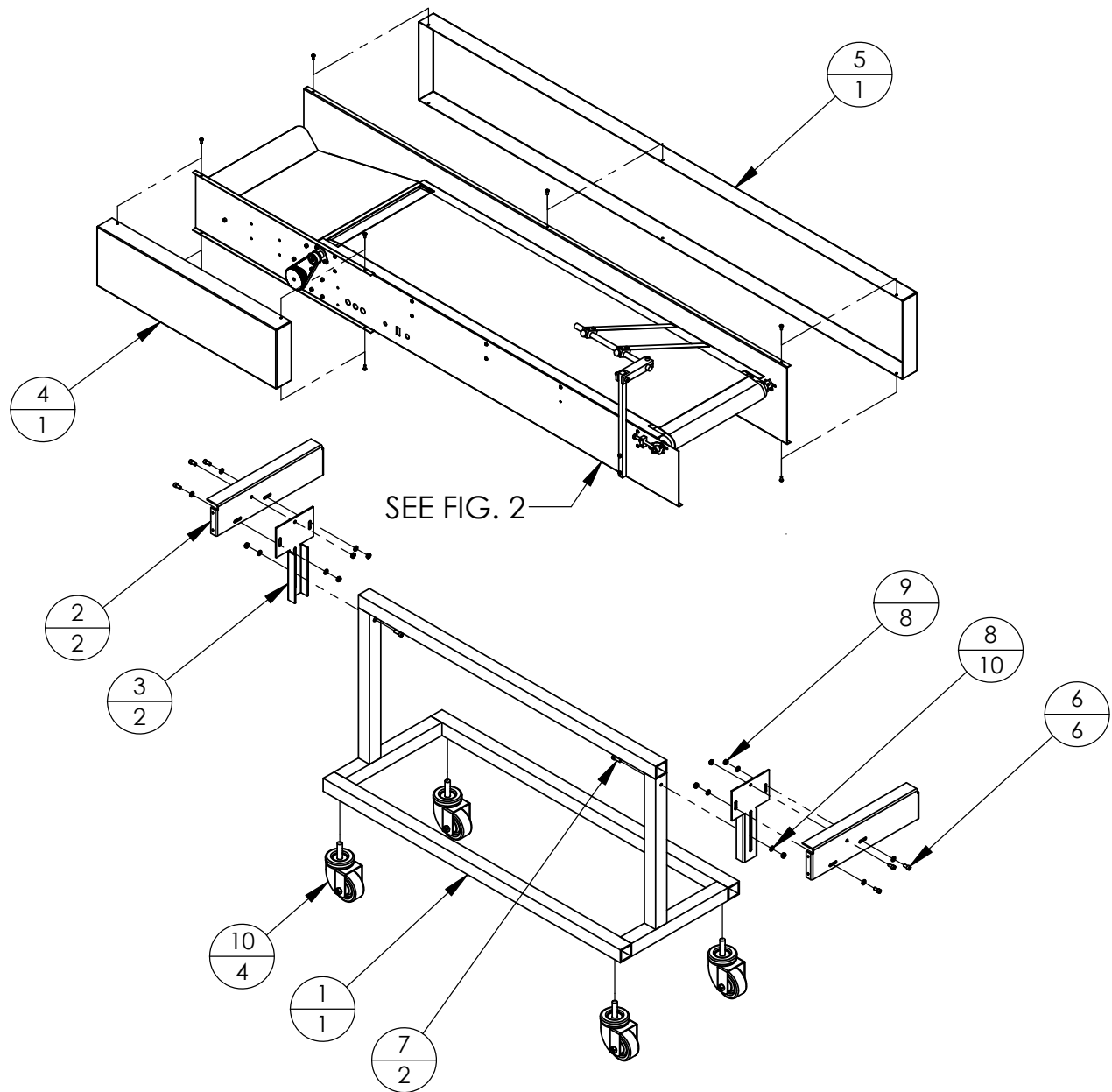

10	99010-005	Purch. Parts, Feet / Casters	4
9	-	NUT, HEX, 1/4-20	8
8	-	WASHER, FLAT, 1/4	10
7	-	BOLT, SKT HD, 1/4-20 X 3/4	2
6	-	BOLT, SKT HEAD, 1/4-20 X 1/2	6
5	12013-003	GAURD, RH	1
4	12013-004	GAURD, LH	1
3	12009-003	BRACKET, PIVOT	2
2	12008-008	CROSS BRACE	2
1	12010-005	BASE, FRAME	1
ITEM NO.	PART NUMBER	DESCRIPTION	QTY

# ***INSERTER 5' SHINGLING CONVEYOR***

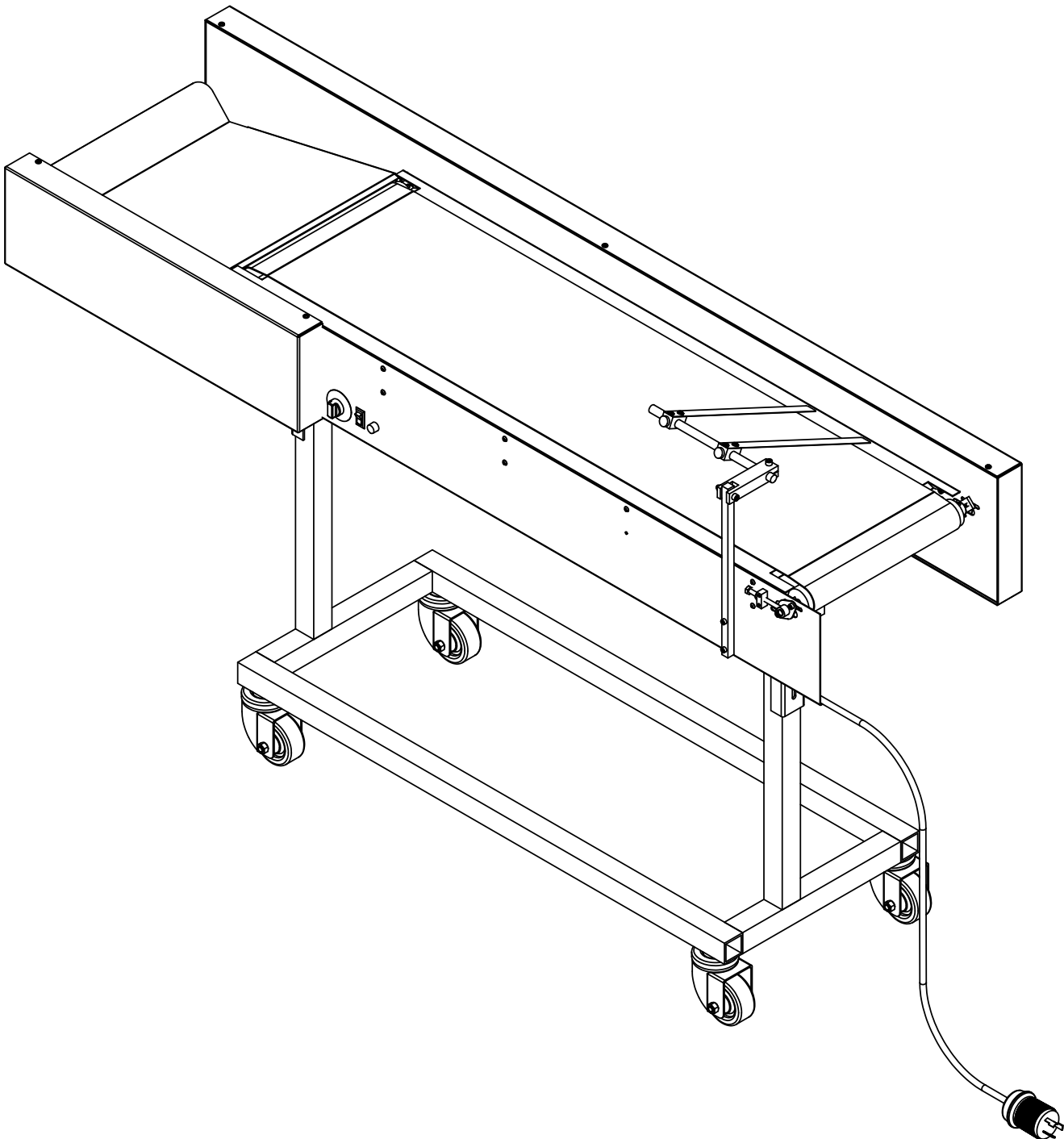
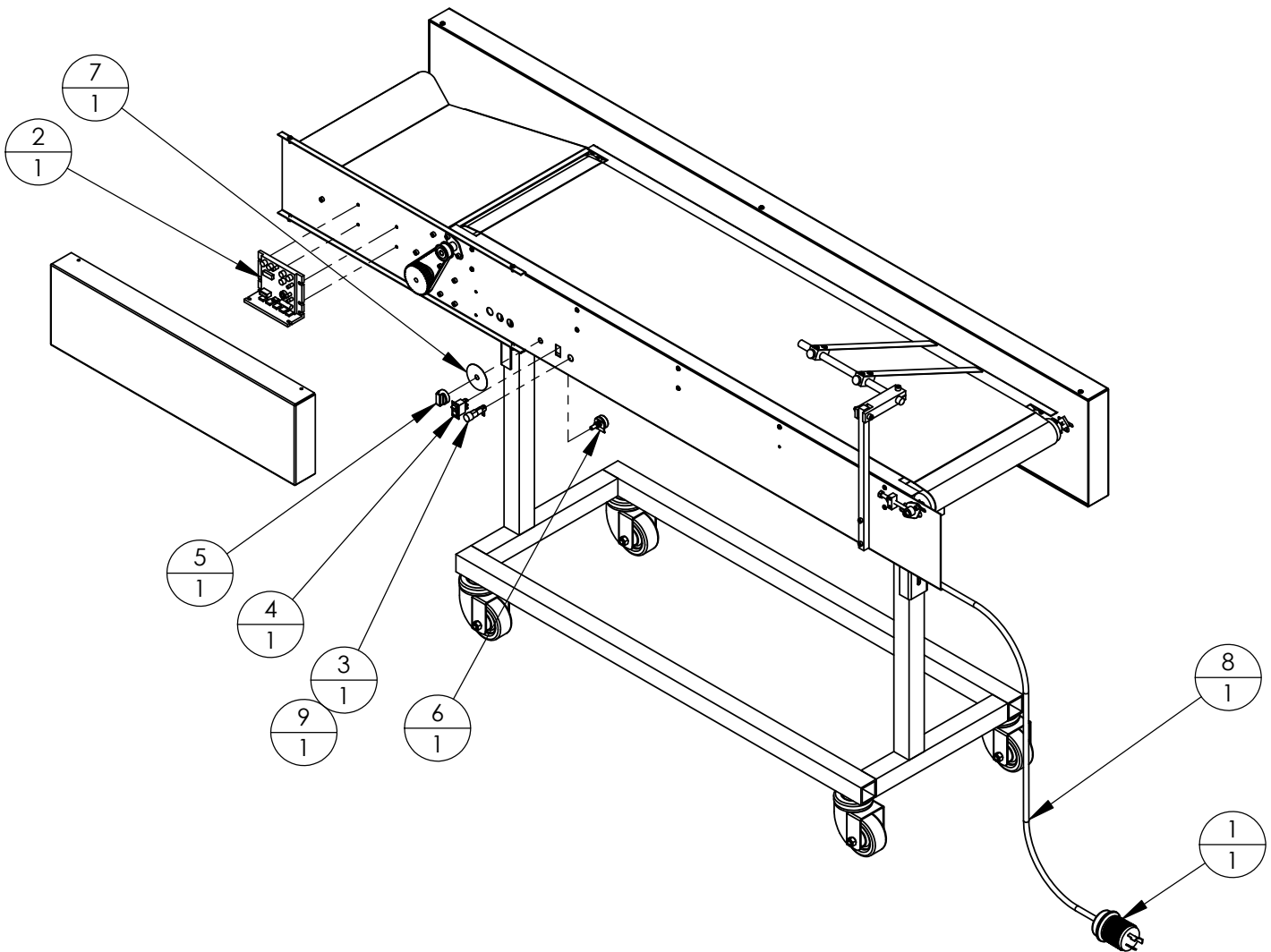

FIGURE 4



ITEM NO.	PART NUMBER	DESCRIPTION	QTY
9	98004-049	FUSE, 3 AMP	
8	98010-016	CALBE, 12/3, SJOW, BLACK	1
7	98006-004	DIAL, SPEED POT	1
6	98006-007	SPEED POT, 5K	1
5	99004-015	KNOB, SPEED POT	1
4	98000-001	SWITCH, ROCKER, RED	1
3	98004-007	FUSE HOLDER	1
2	98005-007	MOTOR CONTROLLER, 90V DC	1
1	98003-017	PLUG, MALE, 20A, 250VAC	1