

Sure-Feed Engineering Inc.

SE-1200-IJ

Operation & Parts Manual

Sure-Feed
Engineering Inc



SURE-FEED
engineering, inc.

3360 Scherer Drive St. Petersburg, FL 33716

PHONE: 727.571.3330 FAX: 727.571.3443 1-800-INSERTER

www.sure-feed.com

SE 1200 IJ

OWNERS MANUAL

Table of Contents

- 1. Installation guide**
- 2. Set-up/operation instructions**
- 3. Cleaning**
- 4. Troubleshooting**
- 5. Parts manual**
- 6. Warranty information**
- 7. Electrical schematic**

**INSTALLATION OF SURE-FEED SE 1200 IJ
(BUSKRO 400 and 600)**

1. Disconnect the shuttle feed crank arm inside the main cabinet of the Buskro machine. Move shuttle feeder to the forward most position and then back off 1/8". Secure the shuttle feeder in this position. (This can be accomplished by applying tape to the seam between the shuttle feeder and the top surface of the machine).
2. Place the SE 1200 IJ feeder in position over shuttle feeder.
- 3a. To install the feeder without removing the bridge assembly, place the feeder in position approximately 2 inches in front of the gate. Raise the gate and feed rollers to their maximum height. As the material exits the feeder, the Buskro skid bar will carry material away from the feeder.
- 3b. Or, to eliminate any potential obstructions, the bridge assembly may be removed. This can be accomplished by removing the jam detector micro-switch and the four allen screws located on the outer sides of the bridge. The roller balls may or may not need to be removed, depending on the length of the material being fed.
4. Wiring: To insert the pigtail into the electrical box, on the top of the box locate the romex connector leading into the box. Loosen the screws and insert the stripped end of the pigtail. In the electrical box locate the terminal blocks. Locate the green/yellow terminal block on the top set of terminal blocks. Loosen the screw on the top of the terminal block and insert the green/yellow wire connecting the feeder. Next locate T2 on the top terminal blocks. Loosen the screw on the top of the terminal block and insert the white wire connecting the feeder. **CAUTION: On BK600, DO NOT connect the white wire to L2.** Locate FU1 this is the black fuse holder with a white pullout holder on the 2nd row of terminal blocks. Loosen the top screw of the fuse holder and insert the black wire. The feeder will start and stop with the Buskro base.
5. There is an extra power cord supplied with the feeder for bench testing. This is helpful for learning how different feeder adjustments and material conditions affect the performance of the feeder.

**Sure-Feed Engineering Inc.
Set-up/Operation Instructions**

1. With the feeder ON/OFF switch in the off position, loosen the two side guides and move them all the way to the sides of the feeder. Then loosen the rear guide ramp and move it all the way back out of the way.
2. Place a single piece of the material to be fed on the feeder centering the material relative to the separating device.
3. Move each side guide in to meet the material and then back them off about 1/16".
4. Tighten the thumbscrew on each side guide.
5. Turn the separator knob clockwise until you can easily pass the single piece of material under the separator. While moving the material back and forth under the separator, turn the separator knob counter-clockwise until you feel resistance from the separator. At this point, you have roughed in the separator setting and will need to tune it in after the completion of the following set-up steps.
6. Place a handful of material in the feeder allowing the material to shingle forward into the separator.
7. Move the back guide forward so as to use the back guide wedge shape to support the back edge of the material stack. At this point, you have roughed in the back guide setting and will need to tune it in later.
8. Add about enough material to the stack to fill about half the height of the side guides.
9. Adjust the side guides so that the top of each side guide flares out slightly so as to create a funnel effect and then tighten the thumbscrews and tighten the ratchet handle on each side guide to lock them in place.
10. You are now ready to feed some material. With the power still off, turn the speed control counter-clockwise to the minimum position.

Sure-Feed

Engineering Inc

11. Turn the power switch on and observe the consistency in which the material is feeding.
12. By turning the separator knob slightly in either direction, you will change the way the material is separating.
13. By moving the back guide in and out, you will quickly find the position that creates the most consistent shingle effect.
14. On models with rear elevator belts, loosen the thumbscrews on the side frames and raise and lower the belts as needed. Longer materials will utilize the raised belts most often.
15. One important item to note; There is no substitution for experience. By working with the SE 1200 IJ, you will notice that the combination of separator setting and the back guide adjustment together will have the greatest effect on separation. Generally, the longer the piece of material, the flatter the material stack should be. Conversely, the shorter the piece of material, the closer the back guide adjustment should be to the material, adding wedge to the material stack. You will also notice that by moving the back guide forward (increasing the wedge), you can open the separator and still achieve good separation.

**Sure-Feed Engineering Inc.
SE 1200 IJ Cleaning Instructions**

Clean rollers and belts are very important to the performance of the feeder. Use a clean rag dampened with Isopropyl Rubbing alcohol, 70% by volume (typically available in drug stores) to clean belts and rollers. Do not use any other solvents, cleaners, or abrasive cleaners on the rollers or belts as they may damage the rubber.

Warning: Isopropyl rubbing alcohol is very flammable! Always unplug the machine before cleaning belts and rollers. DO NOT! use near an open flame, sparks, or any other source of ignition. DO NOT! smoke in the vicinity of the alcohol fumes. Allow used rags to air-dry before throwing them in the trash. Dispose of used rags properly. Other areas of the machine should be wiped clean with a clean dry rag.

**Sure-Feed Engineering Inc.
SE 1200 IJ Troubleshooting Guide**

<u>Problem</u>	<u>Solution</u>
Feeder will not run.	Check fuse condition. Check outlet power source. Check power switch.
Feeder runs but no material is being dispensed.	Check material supply. Remove all material and follow setup procedure. Check rollers and belts for excessive wear or dirt.
Feeder does not create a gap between pieces.	Lower separator adjustment and observe. If a gap is not present after this adjustment, return separator to original position and move the back guide forward. Lower rear elevator belts slightly.
Feeder does not detect material.	Adjust position of the sensor.
Thick material does not feed well.	Decrease the height at the back of the material stack. Increase the opening at the separation device (the thicker the material the less critical the setting is).
Thin material does not feed.	Adjust separation device as described in section 2. Remove material and fan the stack allowing air to separate the pieces. Raise the rear of the material stack by moving the wedge forward.

Sure-Feed
Engineering Inc

SECTION 5

**Sure-Feed Engineering Inc.
SE 1200 IJ parts manual**

Sure-Feed
Engineering Inc

FEEDER ASSEMBLY (Fig. 5-1)

ITEM	PART NO.	QTY.	DESCRIPTION
1	99000-001	1	BELT, TIMING 90XL
2	99000-002	1	BELT, TIMING 110XL
3	99000-003	1	BELT, TIMING 120XL
4	99000-004	3	BELT, RED GUM
5	99000-005	2	BELT, ELEVATOR
6	SEE FIG. 5-2	1	SEPERATOR DEVICE ASSEMBLY
7	SEE FIG. 5-3	1	SIDE GUIDE ASSEMBLY
8	SEE FIG. 5-4	1	FRONT SHAFT ASSEMBLY
9	SEE FIG. 5-5	1	NIP ROLLER SHAFT ASSEMBLY
10	SEE FIG. 5-6	1	SUPPORT IDLER SHAFT ASSEMBLY
11	SEE FIG. 5-7	1	MAIN SHAFT ASSEMBLY
12	SEE FIG. 5-8	1	JACK SHAFT ASSEMBLY
13	SEE FIG. 5-9	1	ELEVATOR SHAFT ASSEMBLY
14	SEE FIG. 5-10	1	PAPER SLIDE ASSEMBLY
15	SEE FIG. 5-11	1	MOTOR ASSEMBLY
16	SEE FIG. 5-12	1	CHASSIS ASSEMBLY
17	SEE FIG. 5-13	1	ELECTRICAL COMPONENT ASSEMBLY
18	SEE FIG. 5-14	1	TRAILING ARM ASSEMBLY

Sure-Feed Engineering Inc

Fig. 5-1

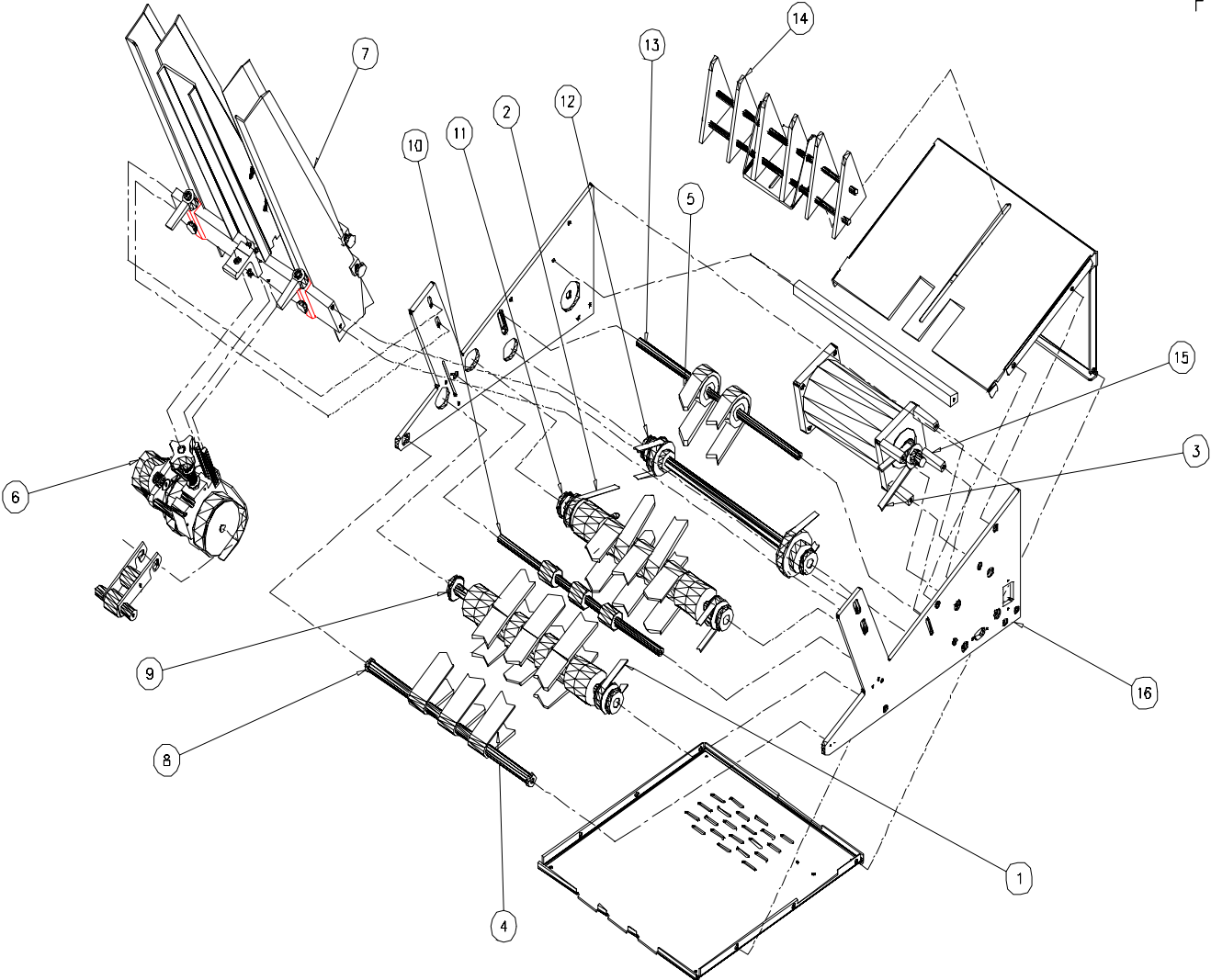

NOTE: ELECTRICAL COMPONENTS ASSEMBLY NOT SHOWN (ITEM 17)

Sure-Feed
Engineering Inc

SEPARATOR DEVICE ASSY (Fig. 5-2)

ITEM	PART NO.	QTY.	DESCRIPTION
1	10007-001	1	BLOCK, SEPARATOR 3" ROLLER
2	10011-001	1	PLATE, MOTOR MOUNT (SEPARATOR)
3	10004-001	1	SHAFT, SEPARATOR
4	10005-003	1	SHROUD, SEPARATOR
5	99001-001	1	MOTOR, SEPARATOR
6	99002-001	1	PULLEY, 100MXL025 (NO HUB 3/8" B.)
7	99002-002	1	PULLEY, 16MXL025 (3/16" B.)
8	10006-001	2	WHEEL, SEPARATOR 3" DIA.
9	99000-006	1	BELT, 115 MXL025
10	10007-010	REF.	BLOCK, SEPARATOR ADJUSTING
11	10004-028	1	STUD, SEPARATOR ADJUSTING
12	99003-001	3	BEARING, 3/8" I.D. X 7/8" O.D.
13	99004-001	1	KNOB 5/16-24 FEM
14	10014-001	2	BELT, SEPARATOR 3"
15	99005-001	1	SPRING, .068 X .48 X 1-7/16"
16	99006-001	1	PIN DOWELL, 3/8" X 1 1/4"
17	10012-002	2	STANDOFF, SEPARATOR MOTOR
18		1	NUT, HEX 5/16-24
19		2	WASHER, FLAT 5/16
20		2	SCREW, PAN HD 6-32 X 2 1/2
21		1	SCREW, SET 10-24 X 1/8
22		4	SCREW, SET 10-24 X 3/8
23		2	SCREW, FL HD 8-32 X 1/2
24	99003-017	5	WASHER, NYLON 3/8 ID X 1/16
25	99003-016	2	WASHER, NYLON 3/8 ID X 1/32
26	99006-002	2	PIN DOWEL, 5/16" X 3"
27	10008-024	1	BAR, SEPERATOR RELEASE

Sure-Feed Engineering Inc

FIG. 5-2

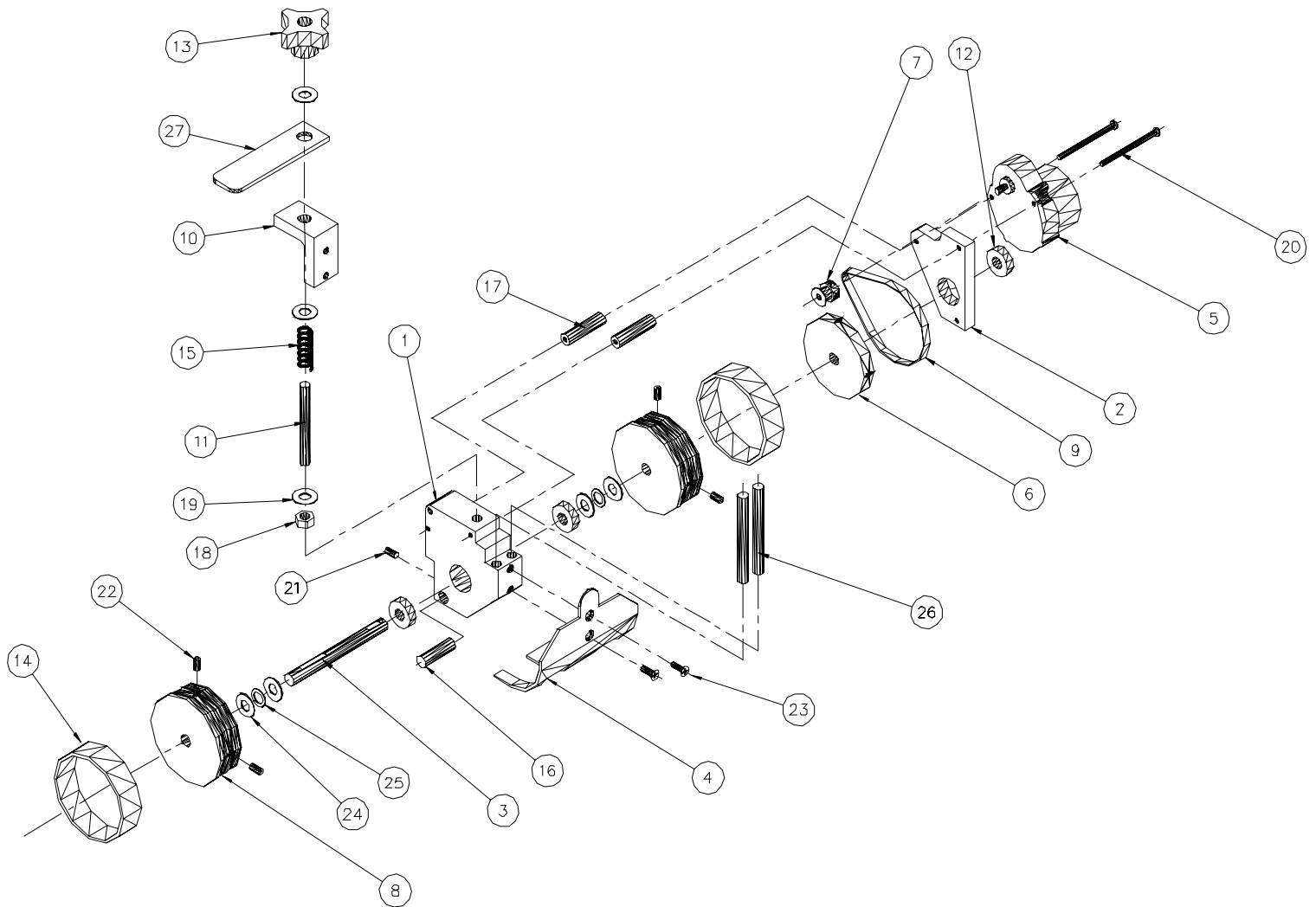

Sure-Feed
Engineering Inc

SIDE GUIDE ASSEMBLY (Fig. 5-3)

ITEM	PART NO.	QTY.	DESCRIPTION
1	10009-002	2	BRACKET, SIDE GUIDE MTG
2	10003-002	1	CROSS BAR, SE-1200-IJ & P
3	10005-009	1	GUIDE, SIDE RH (TALL) SE-1200
4	10005-002	1	GUIDE, FRONT PAPER (TALL)
5	10005-008	1	GUIDE, SIDE, LH (TALL) SE-1200
6	10005-014	1	GUIDE, BUSINESS RH (TALL) SE-1200
7	10007-008	4	BLOCK, BUSINESS GUIDE MTG.
8	10005-015	1	GUIDE, BUSINESS, LH (TALL) 1200
9	99004-002	6	KNOB, #10 SCREW
10		8	SCREW, SKT HD 10-24 X 1/2
11		4	SCREW, BTN HD 10-24 X 1/2
12		4	SCREW FL HD 10-24 X 3/8
13		8	SCREW FL HD 8/32 X 1/2
14		4	SCREW FL HD 6/32 X 1/2
15	10007-010	1	BLOCK, SEPARATOR ADJUSTING
16	99004-003	2	HANDLE, RATCHET, 10-24

Sure-Feed
Engineering Inc

Fig. 5-3

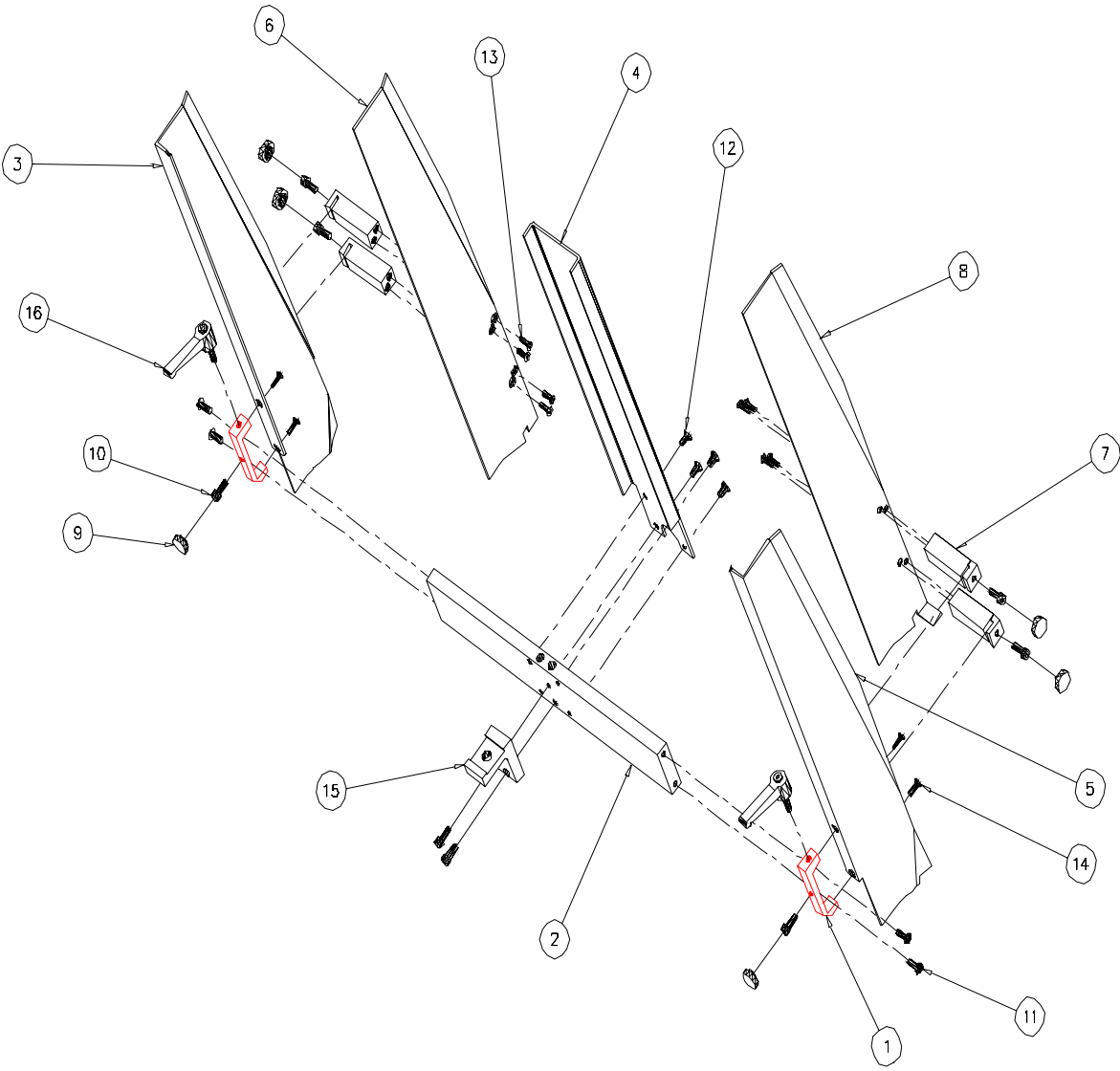

Sure-Feed
Engineering Inc

FRONT SHAFT ASSEMBLY (Fig. 5-4)

ITEM	PART NO.	QTY.	DESCRIPTION
1	10004-024	1	SHAFT, FRONT SE-1200-P & IJ
2	99003-002	2	BEARING, 1/4" ID X 5/8" OD SEALED

Sure-Feed
Engineering Inc

Fig. 5-4

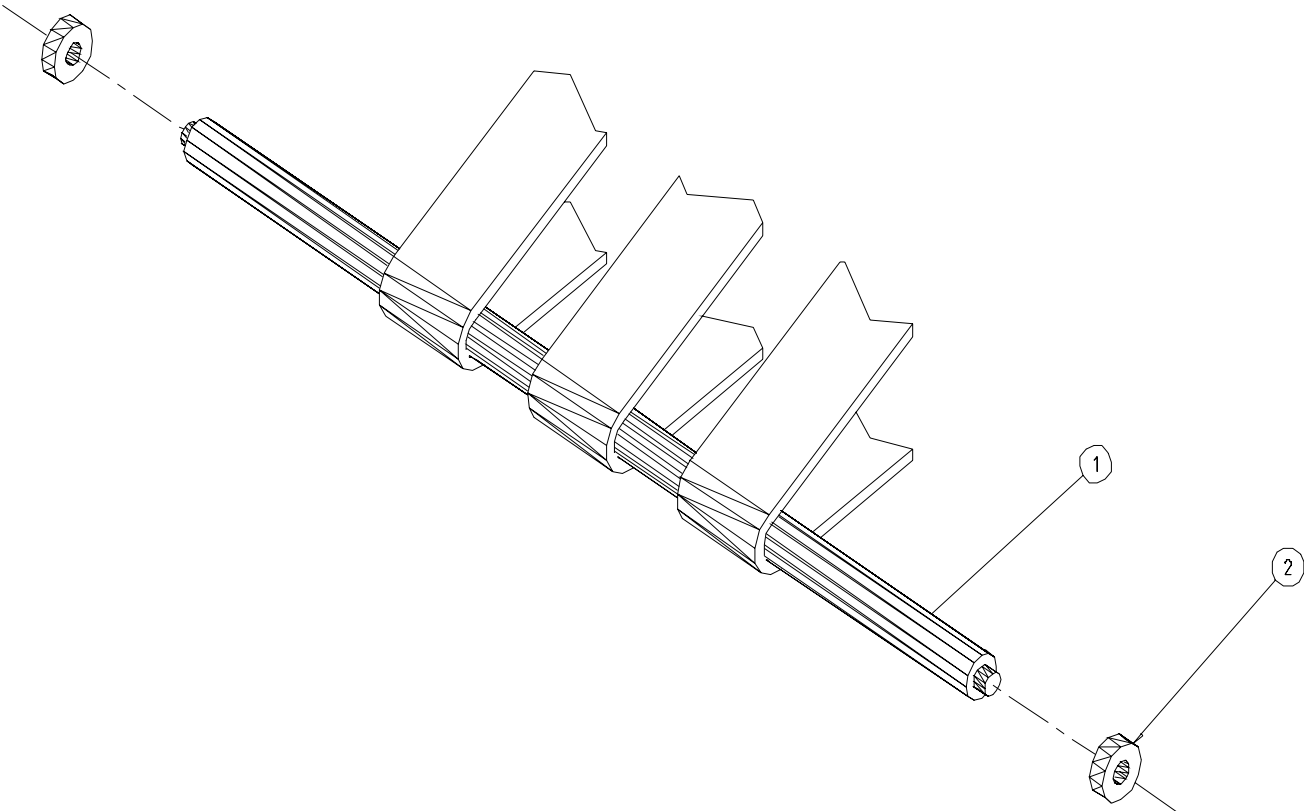

Sure-Feed
Engineering Inc

NIP ROLLER SHAFT ASSEMBLY (Fig. 5-5)

ITEM	PART NO.	QTY.	DESCRIPTION
1	10006-007	4	FEEDER ROLL
2	10006-013	2	NIP ROLLER
3	10006-015	3	PULLEY, MATE
4	10004-022	1	SHAFT, NIP ROLLER SE-1200-P & IJ
5	99002-003	1	PULLEY, 20XL037
6	99003-003	2	BEARING, 1/2" ID X 1-1/8" OD W/GROOVE
7	99022-004	2	RETAINING RING 1/2
8		10	SCREW, SET 10-24 X 3/8
9		2	SCREW, SET 8/32 X 3/8

Sure-Feed
Engineering Inc

Fig. 5-5

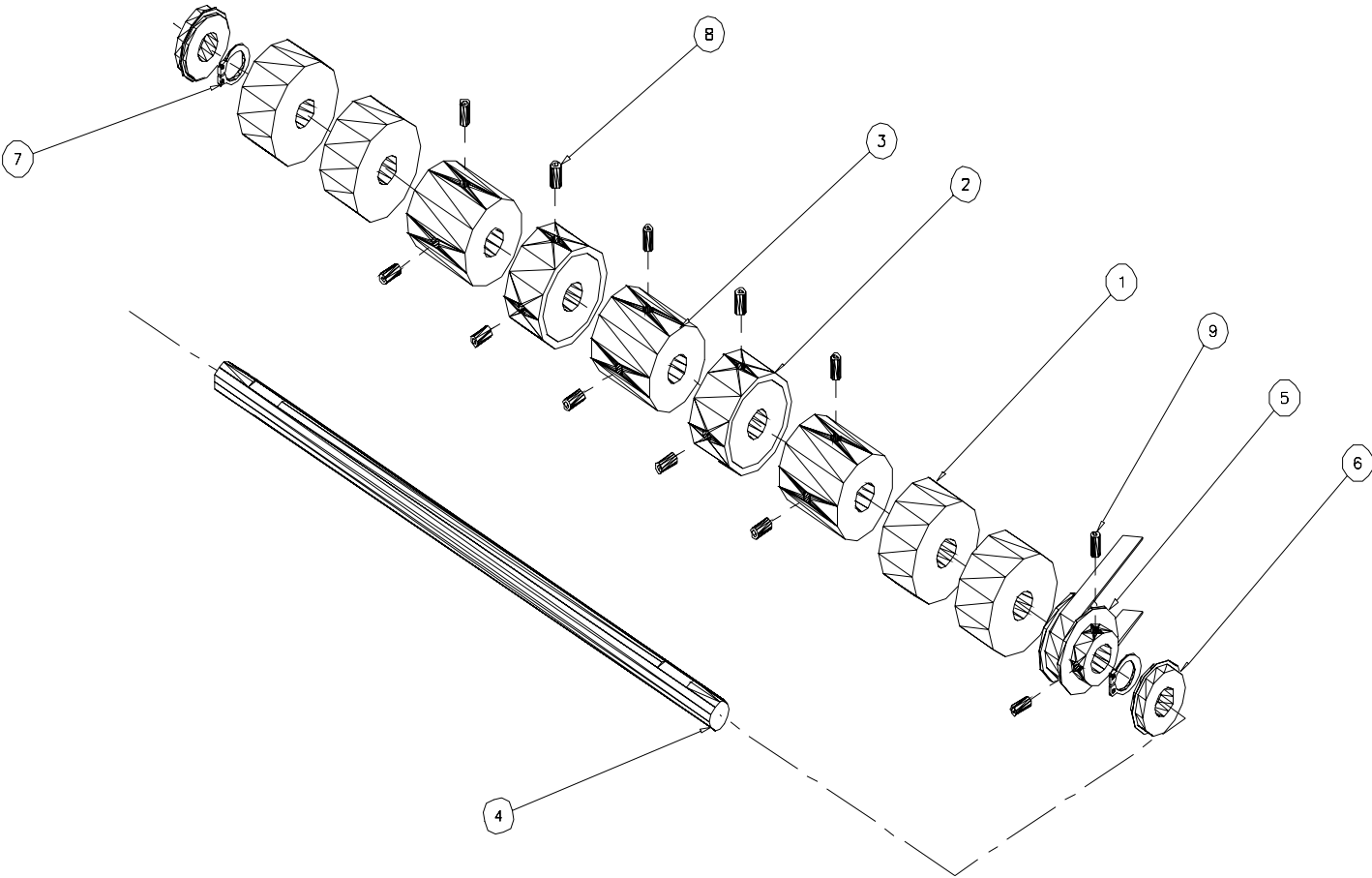

Sure-Feed
Engineering Inc

SUPPORT IDLER SHAFT ASSEMBLY (Fig. 5-6)

ITEM	PART NO.	QTY.	DESCRIPTION
1	10006-012	3	ROLLER, IDLER
2	10004-023	1	SHAFT, SUPPORT IDLER SE-1200-P & IJ
3	99003-001	6	BEARING, 3/8 ID X 7/8 OD
4	99022-003	6	RETAINING RING 3/8
5		2	SCREW, BTN HD 10-24 X 1/2

Sure-Feed
Engineering Inc

Fig. 5-6

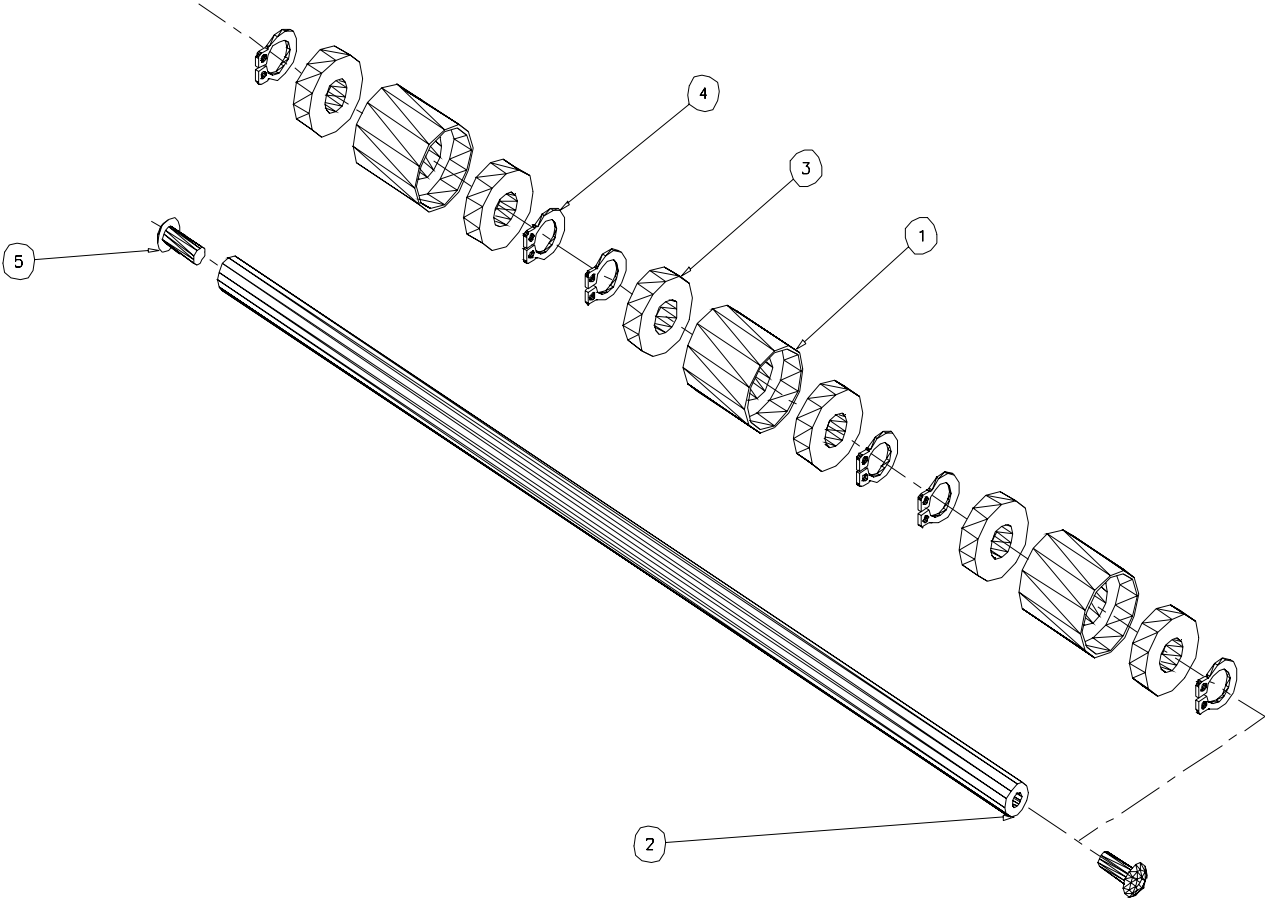

Sure-Feed
Engineering Inc

MAIN SHAFT ASSEMBLY (Fig. 5-7)

ITEM	PART NO.	QTY.	DESCRIPTION
1	10006-007	4	FEEDER ROLL
2	10006-018	3	PULLEY, CROWNED (GUM BELT DRIVE)
3	10004-022	1	SHAFT, NIP ROLLER SE-1200-P & IJ
4	99002-003	1	PULLEY, 20XL037
5	99002-004	1	PULLEY, 22XL037
6	10006-021	2	PULLEY, DRIVE 22XL875
7	99003-003	2	BEARING, 1/2" ID X 1-1/8" OD W/GROOVE
8	99022-004	2	RETAINING RING 1/2
9		10	SCREW, SET 10-24 X 3/8
10		4	SCREW, SET 8/32 X 3/8

Sure-Feed Engineering Inc

Fig. 5-7

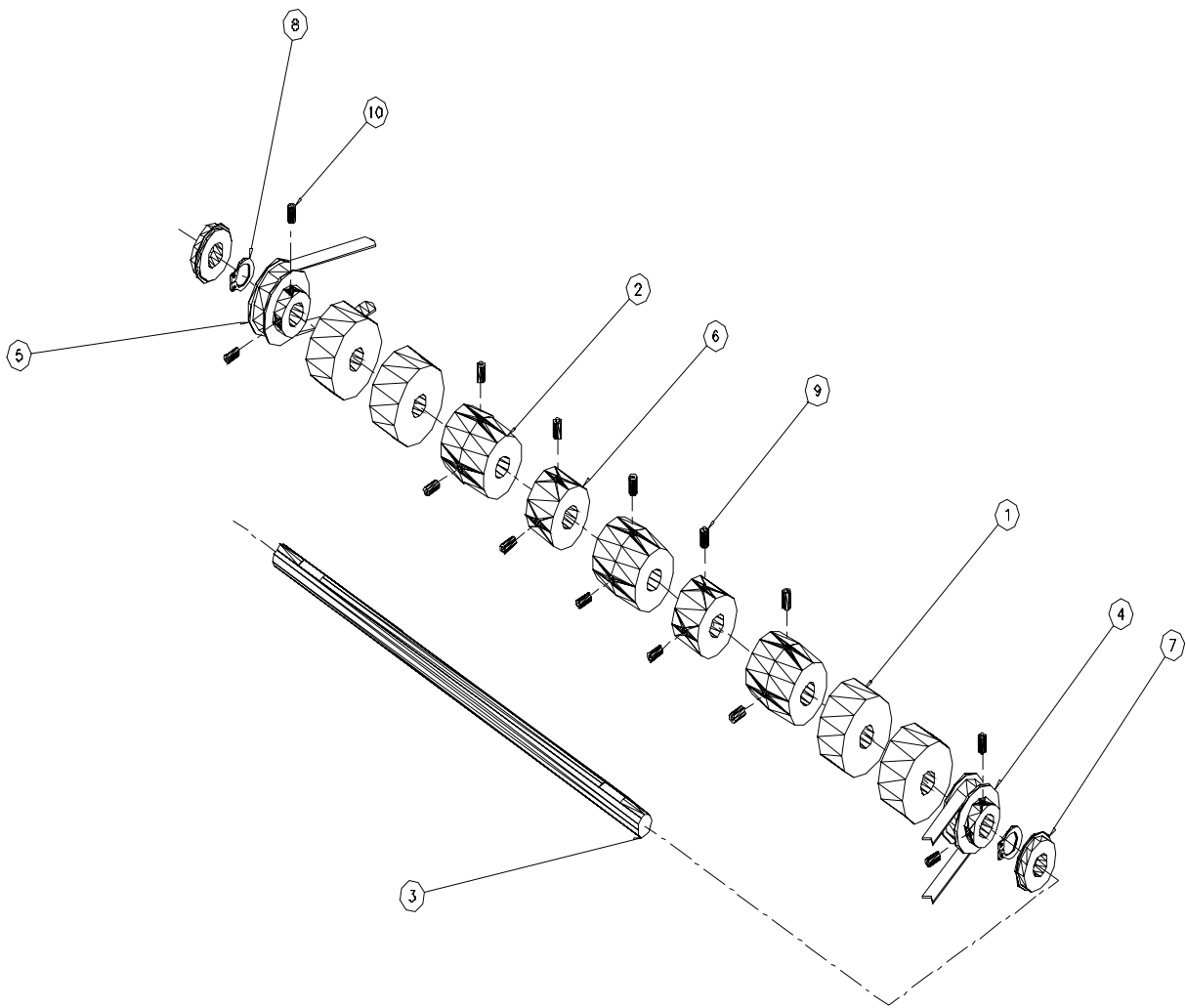

Sure-Feed
Engineering Inc

JACK SHAFT ASSEMBLY (Fig. 5-8)

ITEM	PART NO.	QTY.	DESCRIPTION
1	10004-022	1	SHAFT, NIP ROLLER SE-1200-P & IJ
2	99002-005	1	PULLEY, 36XL037
3	99002-006	1	PULLEY, 24XL037
4	99003-003	2	BEARING, 1/2" ID X 1-1/8" OD W/GROOVE
5	99022-004	2	RETAINING RING 1/2
6		2	SCREW, SET 1/4-20 X 3/8
7		2	SCREW, SET 8/32 X 3/8

Sure-Feed
Engineering Inc

Fig. 5-8

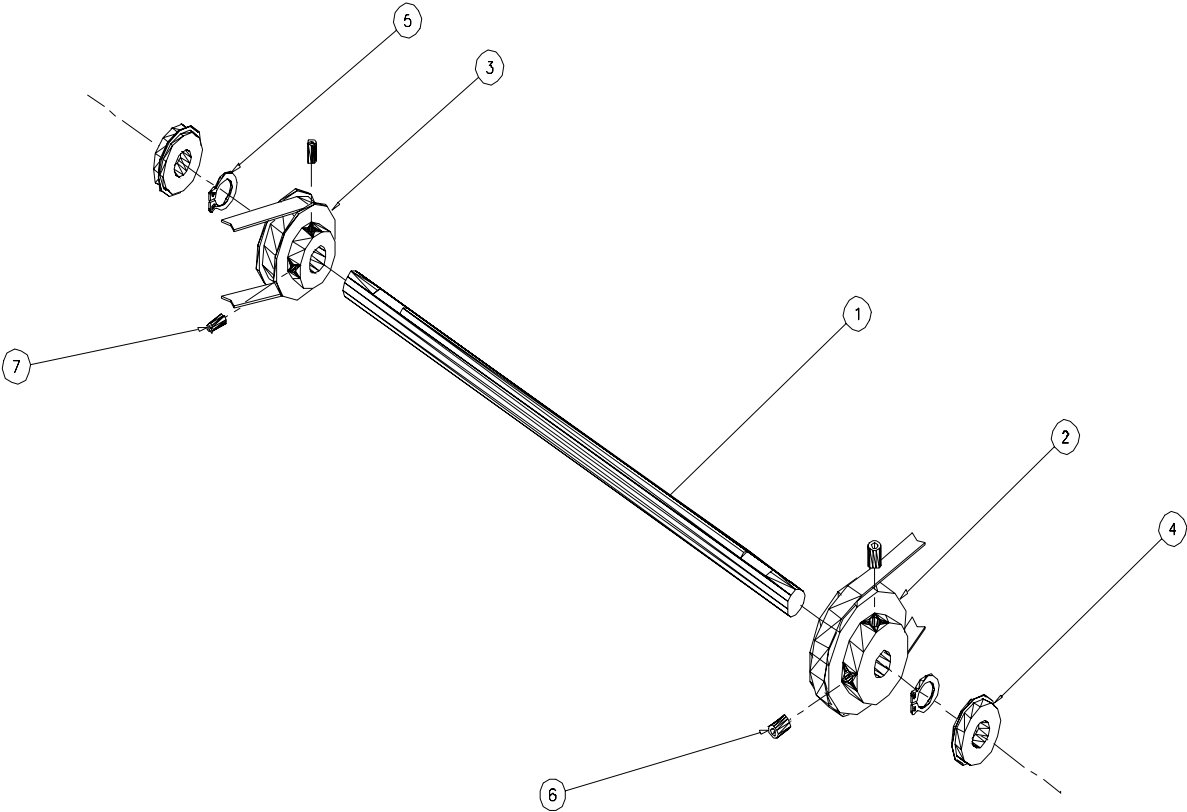

Sure-Feed
Engineering Inc

ELEVATOR SHAFT ASSEMBLY (Fig. 5-9)

ITEM	PART NO.	QTY.	DESCRIPTION
1	10004-023	1	SHAFT, SUPPORT IDLER SE-1200-P & IJ
2	10006-022	2	PULLEY, IDLER 24XL875
3	99003-001	4	BEARING, 3/8 ID X 7/8 OD
4	99022-003	4	RETAINING RING 3/8
5	99004-002	2	KNOB, #10 SCREW
6		2	SCREW, SKT HD 10-24 X 1/2
7		2	WASHER, FLAT, #10

Sure-Feed
Engineering Inc

Fig. 5-9

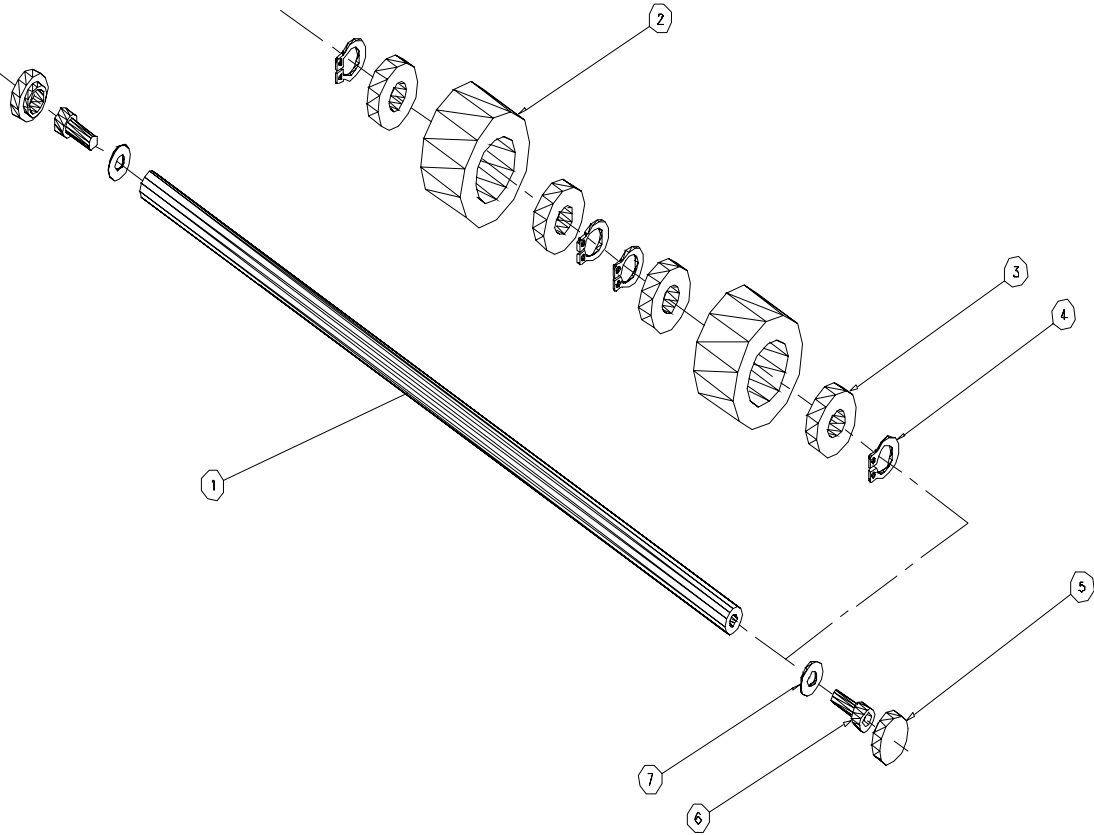

Sure-Feed
Engineering Inc

PAPER SLIDE ASSEMBLY (Fig. 5-10)

ITEM	PART NO.	QTY.	DESCRIPTION
1	10009-003	1	BRACKET, PAPER SLIDE
2	10004-006	2	SHAFT, PAPER SLIDE SE-1200
3	10005-016	6	SLIDE, PAPER
4	99022-001	8	RETAINING RING, 1/4"
5	99004-002	1	KNOB, #10 SCREW
6		1	SCREW, SKT HD, 10-24 X 1/2
7	10007-003	1	NUT, PAPER SLIDE
8	10007-004	1	WASHER, PAPER SLIDE
9	99006-020	1	PIN, ROLL, 5/32 X 3/4
10		1	WASHER, FLAT, #6

Sure-Feed Engineering Inc

Fig.5-10

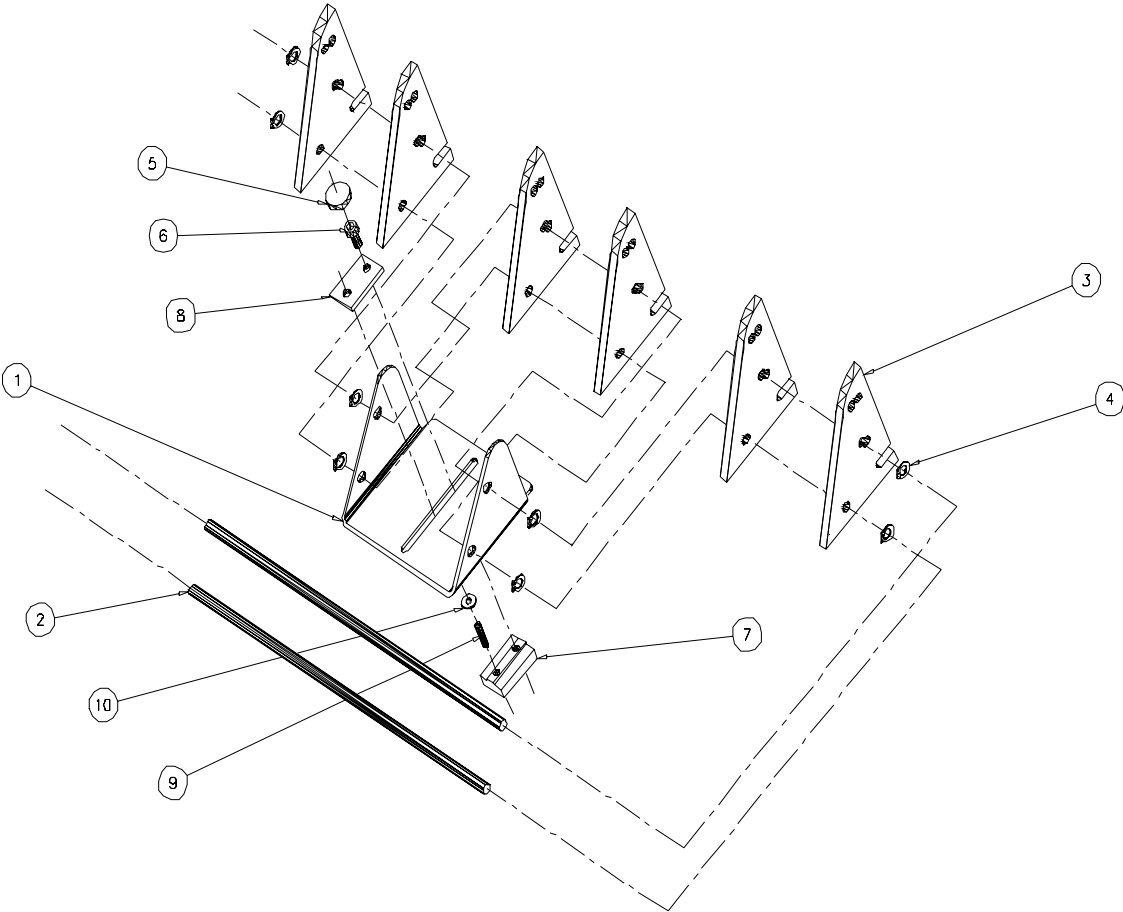

Sure-Feed
Engineering Inc

MOTOR ASSEMBLY (Fig. 5-11)

ITEM	PART NO.	QTY.	DESCRIPTION
1	10012-004	4	STANDOFF, MOTOR SE1200
2	99002-007	1	PULLEY, MOTOR 16XL037
3	99001-002	1	MOTOR, 4Z140
4		4	SCREW, SET, 1/4-20 X 3/4
5		4	SCREW, BTN HD, 10-24 X 1/2
6		2	SCREW, SET, 8-32 X 1/4

Sure-Feed
Engineering Inc

Fig.5-11

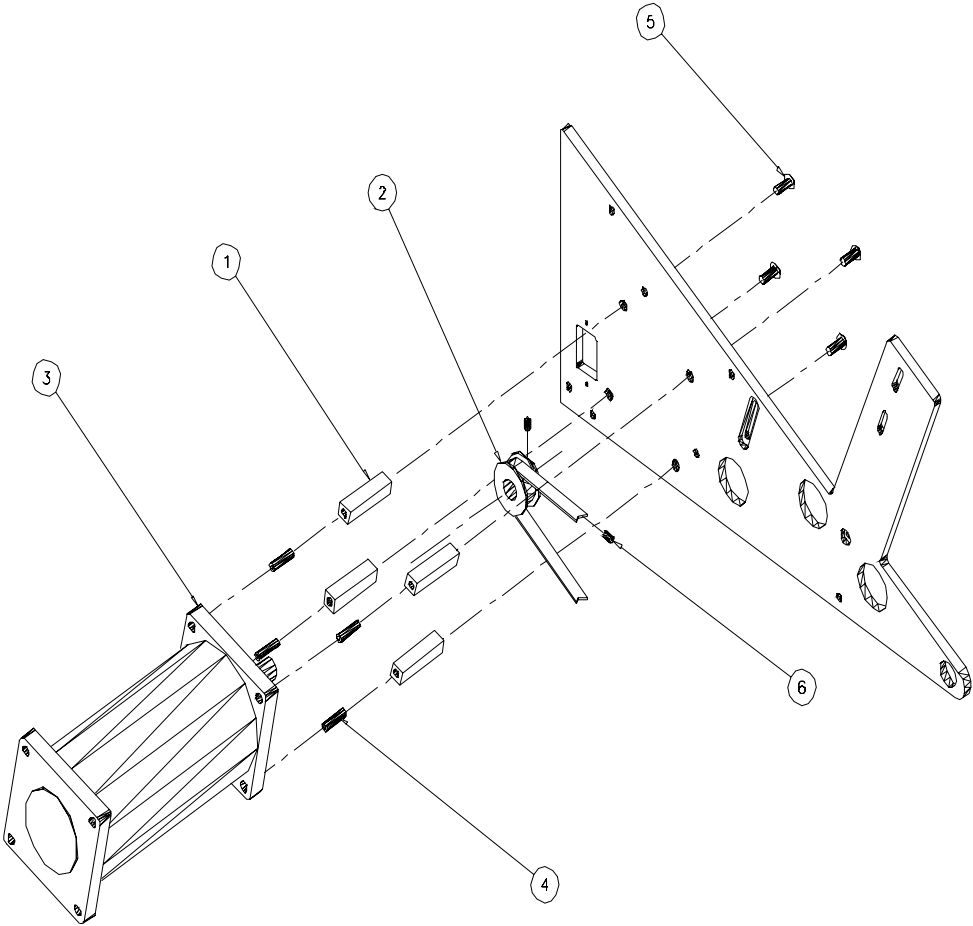

Sure-Feed
Engineering Inc

CHASSIS ASSEMBLY (Fig. 5-12)

ITEM	PART NO.	QTY.	DESCRIPTION
1	10000-003	1	SIDE FRAME, LH SE-1200-IJ
2	10000-004	1	SIDE FRAME, RH SE-1200-IJ
3	10001-003	1	COVER, TOP
4	10002-002	1	PLATE, BOTTOM
5	10008-008	1	CROSS BRACE
6	99007-001	4	SUCTION CUP, FOOT
7		2	SCREW, BTN HD 10-24 X 1/2
8		10	SCREW, BTN HD 10-24 X 1/4
9		10	NUT, PEM 10-24
10		4	NUT, HEX 8-32
11		4	WASHER, LOCK #8

Sure-Feed Engineering Inc

Fig. 5-12

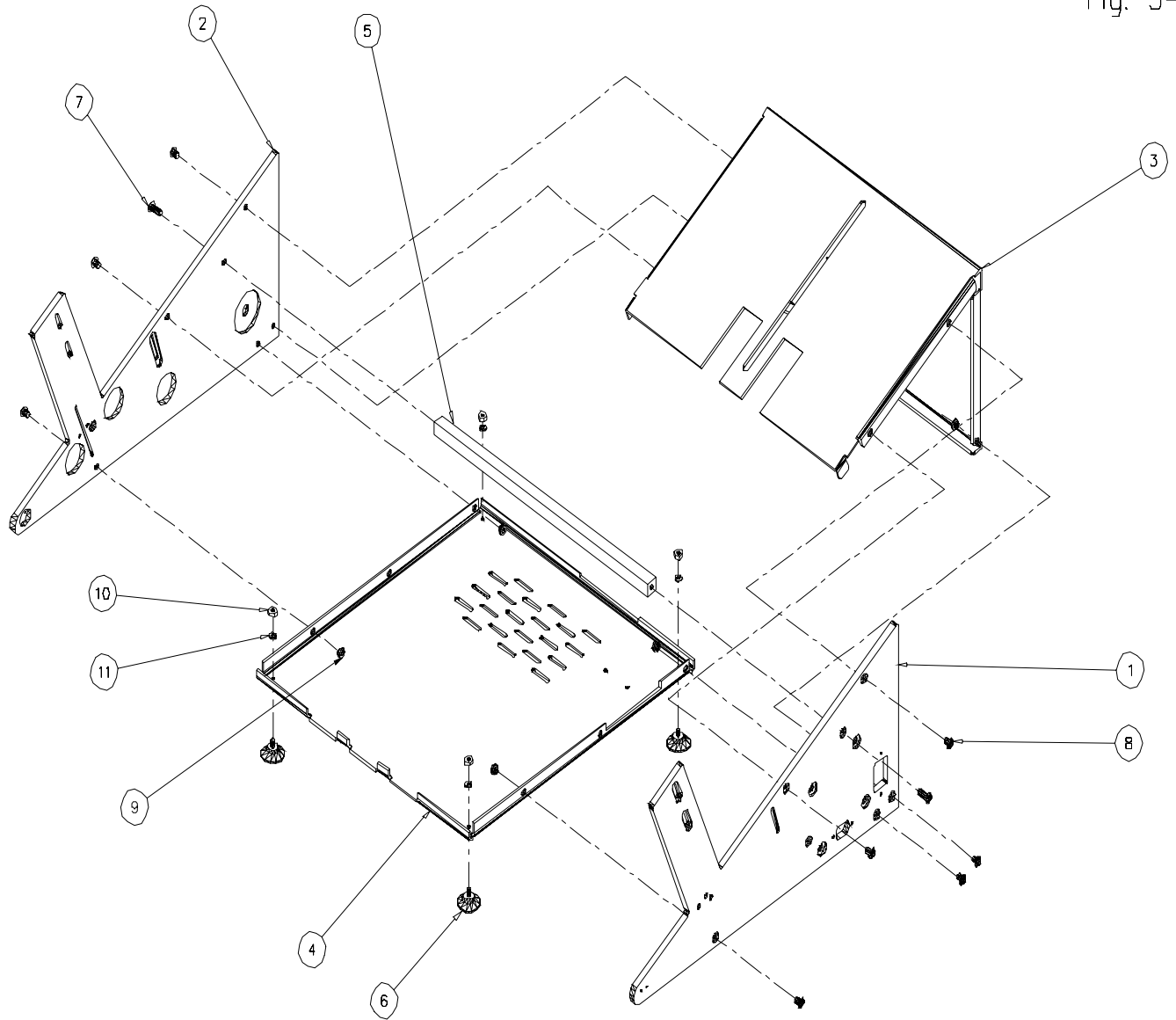

Sure-Feed
Engineering Inc

ELECTRICAL COMPONENT ASSEMBLY (Fig. 5-13)

ITEM	PART NO.	QTY.	DESCRIPTION
1	98000-001	1	SWITCH, POWER (RED ROCKER)
2	98001-002	1	TERMINAL STRIP, 12 CONN
3	98002-001	1	RELAY, TIME DELAY
4	98004-001	1	CIRCUIT BREAKER, 2 AMP
5	98005-001	1	CONTROLLER, MOTOR, 90V DC W/ SPEED POT
6	98003-001	1	RECEPTACLE, POWER CORD
7	98002-002	1	SOCKET, RELAY
8		2	SCREW, PAN HD 6-32 X 3/4
9		6	SCREW, PAN HD 6-32 X 1/2
10		8	NUT, HEX 6-32
11	99004-015	1	KNOB, SPEED POT
12	98007-007	1	CORD, POWER (NOT SHOWN)

Sure-Feed
Engineering Inc

Fig. 5-13

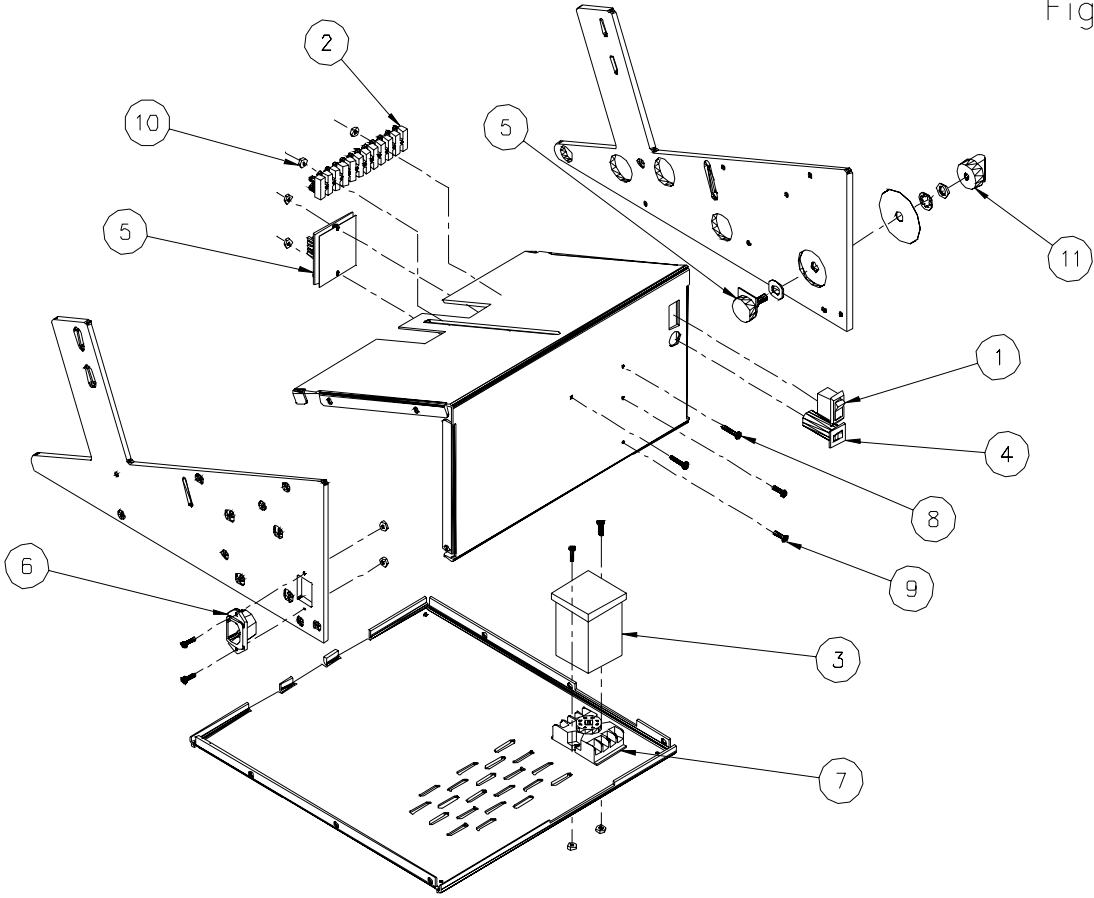

Sure-Feed
Engineering Inc

TRAILING ARM ASSEMBLY (fig. 5-14)

ITEM	PART NO.	QTY.	DESCRIPTION
1	10011-002	2	ARM, TRAILER
2	10012-003	2	SPACER
3	10006-016	2	ROLLER
4	10004-007	2	WEIGHT
5		2	SCREW, PAN HD, 8-32 X 1 1/4
6		2	SCREW, PAN HD, 8-32 X 3/8
7		4	WASHER, LOCK INT. TOOTH #8

Sure-Feed
Engineering Inc

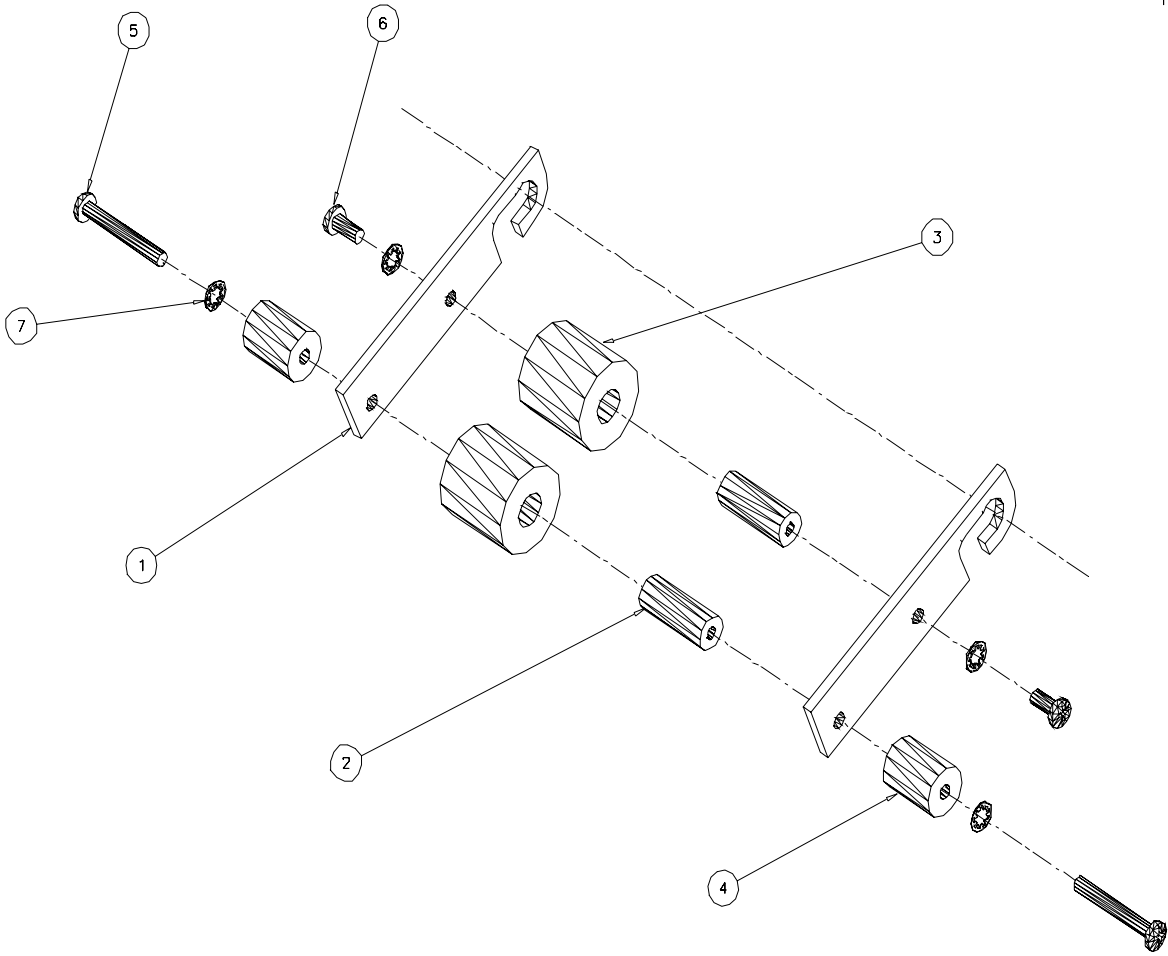

Fig. 5-14

Sure-Feed ***Engineering*** Inc

SECTION 6

Sure-Feed Engineering Inc. SE 1200 IJ

2 Year Limited Warranty

Sure-Feed Engineering Inc. warrants this product to be free from defects in materials and workmanship for a period of two years from the date of delivery to the customer. Sure-Feed Engineering Inc. also warrants the electrical system on all new equipment manufactured to be free from defects in material and workmanship for a period of 90 days from date of delivery to the customer. If at any time during this two year period, the customer feels that there is an alleged defect in the equipment, written notice must be provided to Sure-Feed Engineering Inc. who will determine a time to have the feeder inspected in the field by a representative of Sure-Feed Engineering Inc. or returned to Sure-Feed Engineering Inc. corporate headquarters. If the equipment is found to not be in conformity with this warranty, Sure-Feed Engineering Inc. will in its sole discretion expeditiously either repair the equipment or supply a replacement.

Please refer to the warranty card included with this manual for additional details of this warranty. Complete the warranty card and return it to Sure-Feed Engineering Inc. as soon as possible to activate the warranty on this product.

Procedure

Send all warranty claims to:
Sure-Feed Engineering Inc. Warranty Department
12050 49th Street North
Clearwater, FL 33762
Return freight prepaid.

Sure-Feed
Engineering Inc

SECTION 7

**Sure-Feed Engineering Inc.
SE 1200 IJ Electrical Schematic**

Sure-Feed Engineering Inc

Z1200 IJ

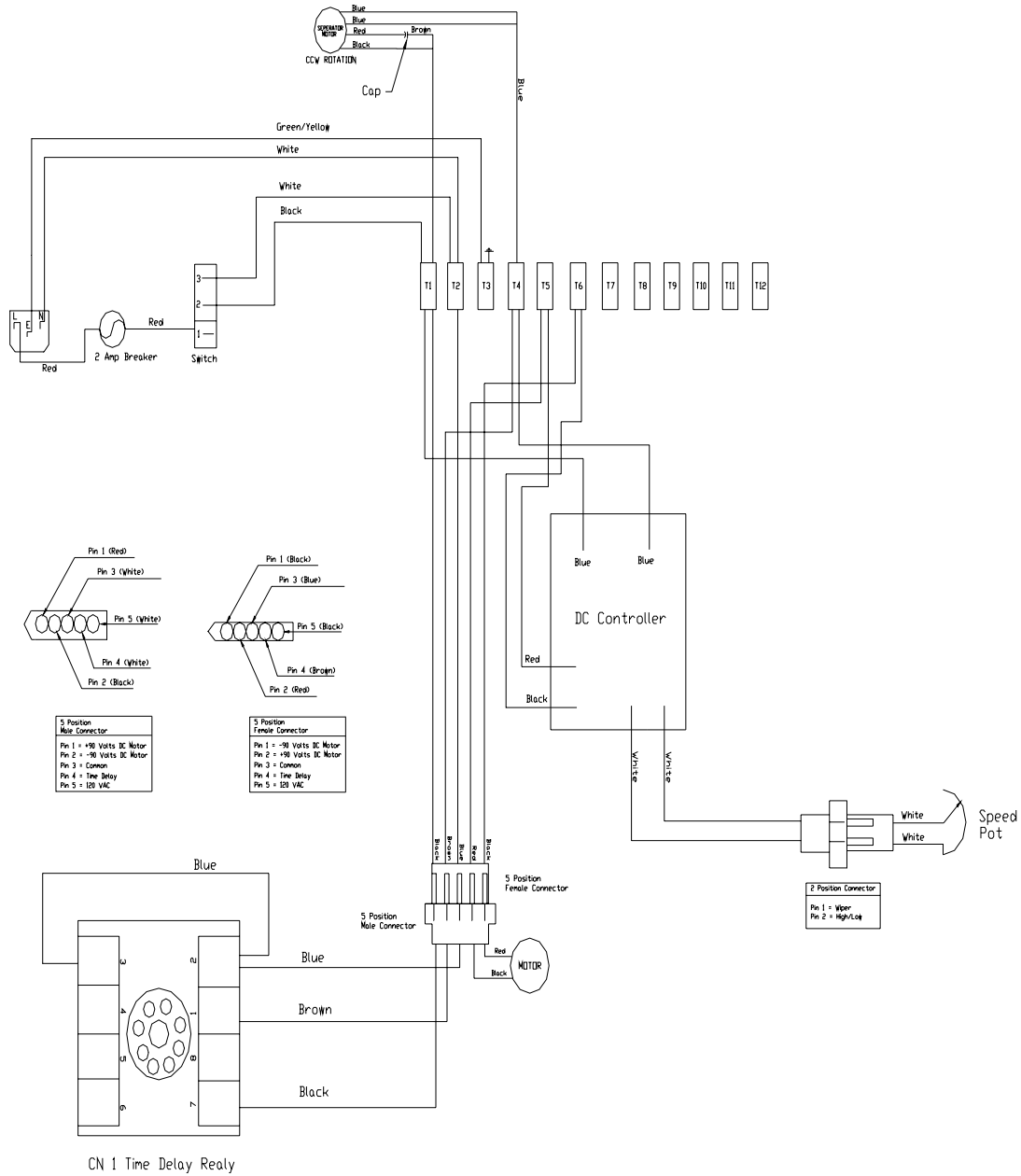

Sure-Feed
Engineering Inc